

RAE CROWTHER CO.

ATHLETIC TRAINING EQUIPMENT

SINCE 1932
DOMINATE WITH FUNDAMENTALS
800.841.5050

2018

www.raecrowther.com

New S Pop Up Tackler



Heavy Leverage



New Sling Ball



New Hooligan Ring



7 Reasons to Go with Rae Crowther...

1. Proven, winning products, plus new innovations
2. Huge inventory in stock
3. Fast shipping
4. Quantity discounts
5. Free shipping on certain products
6. Over 14 new products
7. Easy and friendly ordering by phone, online, or fax

800-841-5050

www.raecrowther.com

803-366-3633

Rip through the ball-carrier with the most realistic pad in the industry!

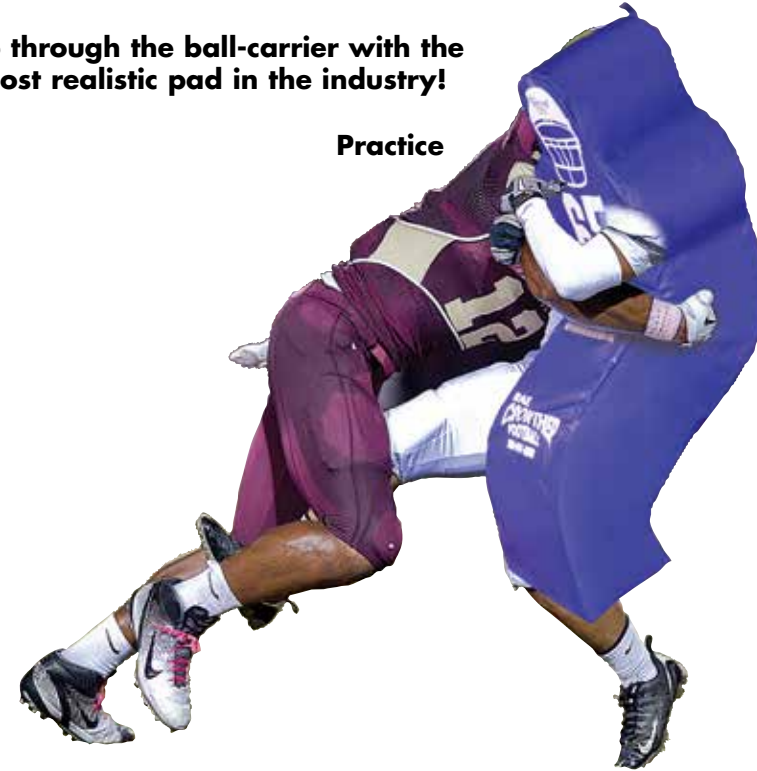

Practice

No other pad gives you the look of a ball-carrier like the S-Pad.

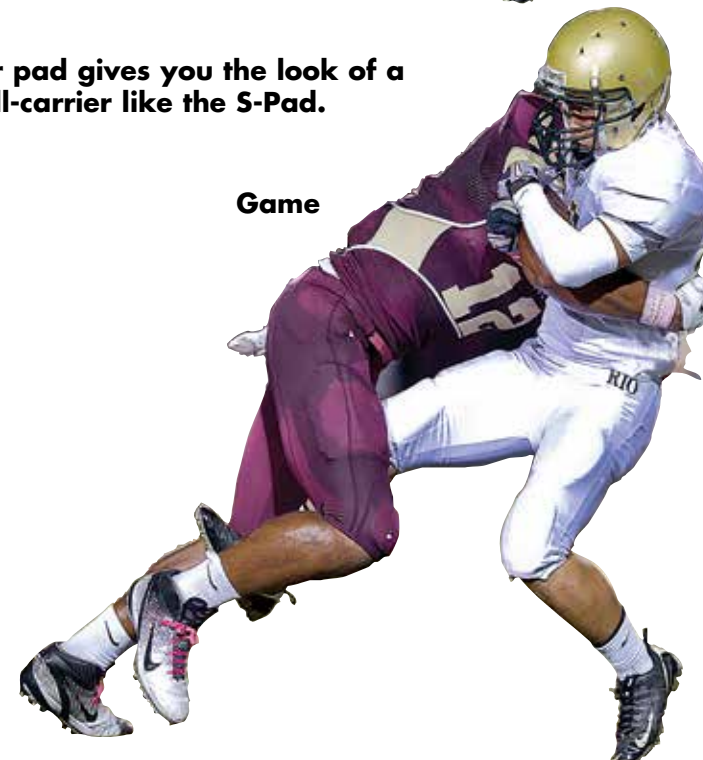

Game



New S-Tackler ...with Pop Up Base

Now you can get the best of both worlds, the patented S Pad shape with a Pop Up sled base. The Pop Up frame allows more reps in practice, as the player or coach does not need to upright the sled. The sled pops up fast! Simply tackle to the ground and let the sled return upright in seconds, ready for the next rep. Some offenses are going to throw 70+ plays a game at your defense, thus tackling and conditioning have never been more important. Good, consistent tackling is the key to stopping offenses, and ripping through the S-Pad with authority in practice translates to fewer spin offs in the game. The metal S spring is surrounded by foam. The S-Pad has a protective two-part cover that is removable for storage. Overlooked is the fact that the S Pop Up Tackler is a great strength and conditioning sled. Driving the sled for yardage (30 to 100 yards) is difficult and directly related to becoming stronger in a football position. Every muscle is strained while in a dynamic hitting or blocking position. The sled incorporates a strength and aerobic element while also enhancing mental and physical toughness. The sled weighs 215 lbs., an ideal weight for high school football. For collegiate and professional teams you can add additional 45 lb. plates to the weight horn on the base of the sled. Powder coated in black. Metal frame is fully welded for durability with a 5 year warranty. S Padding has a 2 year warranty.

Model: SPUT
Model: SPUTD

S Pop Up Tackler with Regular S-Pad
S Pop Up Tackler with Dual Arm S-Pad

Price: \$1395
Price: \$1450

S-Pad Colors	Black	Navy	Royal	Purple	Maroon	Red	Orange	Green
Dual Arm S-Pad Colors	Black	Royal	Red	Green				

FAX: 803-366-3633

Call Toll-Free: 800-841-5050

S-POP UP TACKLER™
US Patent #6,988,965 B2
US Patent #6,942,585 B1

New
2018

New!

Watch these drills...
Go to raecrowther.com or search for Rae Crowther on YouTube for all of our latest videos...



Sling the ball in motion

...drill rip tackling



Stretch the sling tube...
Release the Sling Ball ...
Tackle the fast approaching Sling Ball...

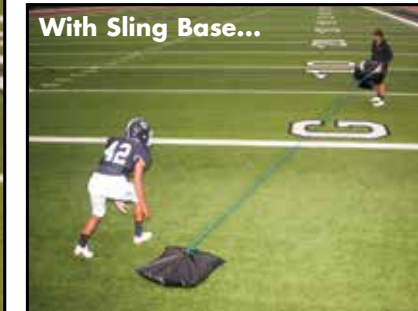

New!

Watch these drills...
Go to raecrowther.com or
search for Rae Crowther
on YouTube for all of our
latest videos...



The Sling-Ball is an affordable new tackling tool that promotes "Rip Tackling." The Sling-Ball is a large 36" diameter round ball. The Sling-Ball weighs 10 lbs. The Sling-Ball attaches to a high density stretch tube (the Sling-Tube). The tube is either attached to a small but heavy base (the Sling-Base weighs 50 lbs.; there is no metal in the base so it won't hurt players if they land on it) or to a waist belt (the Sling-Belt comes in small, medium, and large sizes). When using the Sling-Base the coach holds the Sling-Ball and walks away from the base, stretching the elastic Sling-Tube. The player can be situated in front, behind, or to the side (angle tackle) of the base. When the coach lets go of the ball it acts like a slingshot, zipping the ball back in the direction of the base. The other alternative is to have the player wear the Sling-Belt. The Sling-Belt attaches to the Sling-Tube. In this scenario the player and coach can get maximum reps in a short period of time and in a confined space. We suggest equipping multiple players with Sling-Belts (the Sling-Tube allows quick attachments, only a few seconds) so that the drills can go fast with maximum reps. You can use the Sling-Ball outside on the grass/turf but also, very importantly, inside in the gym. The Sling-Ball is a year-round training device. How fast do you want the Sling-Ball to travel? The velocity of the ball is determined by how far the coach stretches the Sling-Tube. It can be slow (2-4 mph) or really fast (10-15 mph), and the travel of the Sling-Ball can be short or long. The Sling-Tube's resting length is 10'. At maximum length the Sling-Tube stretches 25'. The coaches can hold the ball high when they release it, creating bounce, or close to the ground. The low height of the ball and its round shape promotes knee and ankle flexion, the "Dip and Rip" technique of tackling. The Sling-Ball can also be used without the Sling-Tube. A coach can simply roll the ball at a player and use it in the open field. We suggest a progressive use of the Sling-Ball by first tackling the ball stationary, then stationary at an angle, and only then proceeding to "Slinging" the ball at a player. Warranty 1 year. The color of the vinyl on the ball is black only.

Model: SLB1
Model: SLB5

Sling-Ball Complete (includes Sling-Ball, Sling-Tube, Sling-Base)
optional Sling-Belt (specify large, medium, or small belt)

Price: \$295
Price: \$39

TACKLING RINGS

*Bobby Carroll
Head Coach
York High School
Multiple State Champ Coach*

"The tackling ring was an amazing tool and resource for us this year. With the Ring, we were able to teach the modern concepts of tackling and reduce player-on-player drills. We limited the player-to-player contact, which reduced injuries. We were able to tremendously increase our reps in tackling. In my 33 years of coaching defense, the Ring was huge in helping us teach tackling the correct way. We had NO injuries during our individual tackling drills or our circuit tackling drills. I suggest everyone try the RING!"

New!

Watch these drills...
Go to raecrowther.com or search for Rae Crowther on YouTube for all of our latest videos...



Come Get The Best Rings!

The widest rings in the industry,
with dense, durable foam...



Work the new "Hawk" tackling concepts. Hit and roll. Improve tackling technique with speed, agility, and head position. Intended for many ages. Can be used with or without pads. The rolling ring provides realistic tackling, which allows the coach to diagnose the player's technique. Use multiple rings in practice to keep the repetitions and players moving and improving their skills. The Tackling Ring is made from foam and vinyl. Our rings provide a lot more foam and much denser foam. Our wider rings, for example, the Varsity Ring is 13" wide compared to 8" or 9" width from competitors, are more player realistic, simulating the hip and thigh area, tougher to tackle, more stable for fast and slow drills (as well as on windy days), and provide more player protection when landing on the ring (bottom arm is more protected), and more durable. 4 Ring sizes to choose from; see size and pricing below. Ships motor freight. 2 year warranty.



JR. TACKLING RINGS

Model: TKDJR - BLACK
Size: 32" D x 12" W x 12 lbs.
Regular Price: \$295
Order 2 Rings and get 10% off (\$265)
Order 3 Rings and get 15% off (\$250)
Order 4 Rings and get 20% off (\$236)

FAX: 803-366-3633

VARSITY TACKLING RINGS

Model: TKDV - BLACK/RED/ROYAL
Size: 43" D x 13" W x 20 lbs.
Regular Price: \$395
Order 2 Rings and get 10% off (\$355)
Order 3 Rings and get 15% off (\$335)
Order 4 Rings and get 20% off (\$316)

Call Toll-Free: 800-841-5050

HOOLOGAN TACKLING RINGS

Model: TKD48 - BLACK
Size: 47" D x 10" W x 16 lbs.
Regular Price: \$295
Order 2 Rings and get 10% off (\$265)
Order 3 Rings and get 15% off (\$250)
Order 4 Rings and get 20% off (\$236)

XL TACKLING RINGS

Model: TKDXL - BLACK
Size: 54" D x 17" W x 33 lbs.
Regular Price: \$495
Order 2 and save 10% (\$445)
Order 3 and save 15% (\$420)
Order 4+ and save 20% (\$396)

Order 24/7 at www.raecrowther.com

MOTION TACKLER™

US Patent #8,328,664 B2
 US Patent #6,988,965 B2
 US Patent #6,942,585 B1

Matt Dickmann
 Head Football Coach,
 Seminole Ridge HS

"The Motion Tackler that Seminole Ridge football team bought from you has been an excellent addition to our program. It has been a great tool to teach form tackling. The motion tackler is very versatile since we are able to use it stationary or when moving. Our athletes and coaches feel it has been very beneficial to our program. It is a great way to prevent unwanted injuries in practice when performing tackling drills. The motion tackler can also be used for iso drills with a lead blocker, option drills for the QB and special teams. It will always be a must in any program that I am a part of."

New!

Watch these drills...
 Go to raecrowther.com or search for Rae Crowther on YouTube for all of our latest videos...



The Motion Tackler is the first sled of its kind that can be pushed into motion and then tackled by a player. The sled moves; it's not a stationary target. The Motion Tackler bridges the gap between static tackling and live tackling without the risk of injuring another player. When a player hits the sled and lifts the pad 2", it engages a brake. The brake stops the sled from rolling back at the coach and allows the player to take the sled to the ground. The Motion Tackler takes the wear and tear off beating each other up. Call it the "Gretzky" because it's not where the ball carrier is, it's where he's going! How can coaches effectively teach their athletes how to block and tackle with strict contact limitations? Let Rae Crowther be part of that solution. Tackling or blocking another player is what the sport of football is all about, but hits can add up on the player's bodies and create injuries. New rules and guidelines (i.e. Pac 12, Ivy league, NCAA guidelines, multiple High School State Associations) are calling for less contact during practice. The Motion Tackler is a great answer to the dilemma of skill acquisition while reducing injuries. The benefits of live tackling in practice won't translate to better football if players get hurt and can't contribute in games. Keeping players healthy and increasing their skill level is what the Motion tackler is all about.



Grasping the padded handle bar at the back of the sled, the coach pushes the sled into motion.



The coach releases the sled into free motion; the sled rolls at the player simulating a live ball carrier.



The player contacts the moving sled. When the front of the sled is raised 2" off the ground, the brake at the back of the sled engages the turf and stops the sled from rolling backwards.



The player tackles the sled to the ground, the sled uprights easily with a slight tug on the handle.

Order 24/7 at www.raecrowther.com

Hit a Moving Tackling Sled

... More Fun and Less Chance of Injury in Practice

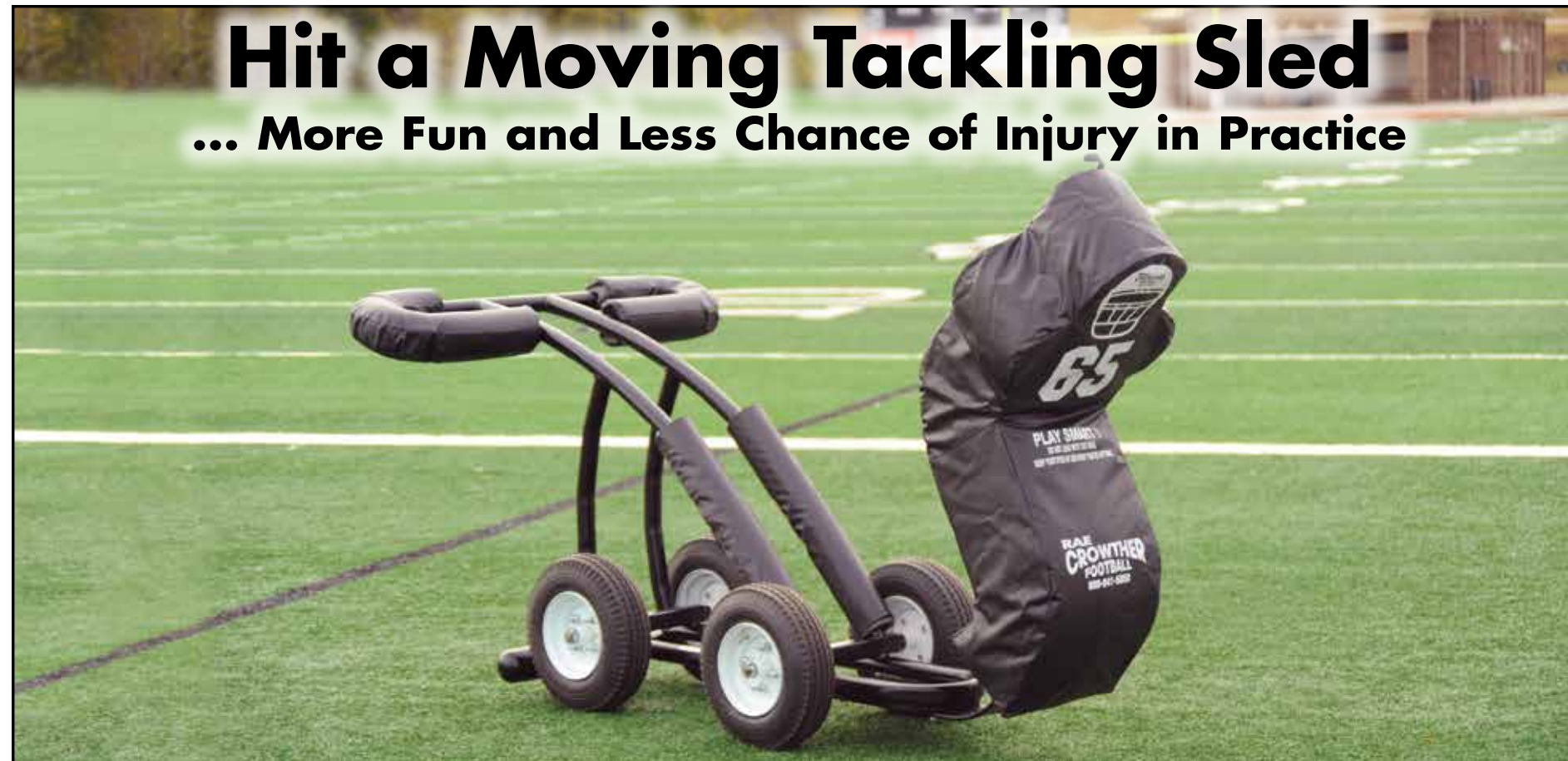

7 Reasons for using the Motion Tackler

Make the Motion Tackler part of your tackling circuit. The Motion tackler can help improve your team and help transfer the skills learned in practice to the game by the following uses: 1) Staying disciplined and not over running the ball carrier and missing. 2) Simulating an angle tackle or an open field tackle. 3) Working on skills of footwork, takeoff, body control, and quickness. Players can improve their body awareness against a moving target and get in the right position to make a tackle. Plus, if you chose, you don't have to take the sled all the way to the ground in each drill. 4) Pass protection and option football. The sled can act as a charging DL. OL's can work on their "hop." 5) Use for QB interference and pocket awareness. 6) From a strength and conditioning perspective coaches can emphasize the development of acceleration, lower body muscular power, and lean muscle mass to improve tackling ability. 7) And, the sled ships free!

Turf tires

The sled rolls on 4 turf tires that will roll over any surface. Each wheel is attached to heavy marine grade axles and 5 bolt wheel hubs. The patented S pad is the player's target. The coaching end of the sled is light and easy to move. For player protection the coach's handle is protected in dense foam as well as the tubular chassis. Paint: Powder coated black. Shipping Dimensions: 60" L x 72" W x 36" H. Warranty: 3 year factory warranty.

Model: 1MT-V2	Motion Tackler with Regular S-Pad	Price: \$1995
Model: 1MTD-V2	Motion Tackler with Dual Arm S-Pad	Price: \$2049

S-Pad Colors	Black	Navy	Royal	Purple	Maroon	Red	Orange	Green
--------------	-------	------	-------	--------	--------	-----	--------	-------

Dual Arm S-Pad Colors	Black	Royal	Red	Green
-----------------------	-------	-------	-----	-------

FAX: 803-366-3633

Call Toll-Free: 800-841-5050



CLASSIC TWO MAN PAN SLED™

Patent # 1,962,088

Howard Mudd
Offensive Line Coach, (retired)
Indianapolis Colts
'06 Super Bowl Champion

"Using the Crowther is the very best way to teach blow delivery. There are only a few things we try to be very good at, and utilizing the Crowther is a big part of learning to strike opponents and move them. The shoulder is a wicked hitting device, and it's been forgotten by many coaches, but I encourage you to go back and learn this powerful and effective means of blocking."

Bobb McKittrick, R.I.P.
Offensive Line Coach
Five Time Super Bowl
Champion

"There's no better way to teach the fundamentals: low center of gravity, explosion of the hips, striking with the forearm, moving the feet, keeping the head up, butt lower than shoulders, back straight, knees bent, taking short driving steps, than with the Crowther."

New!

Watch these drills...
Go to raecrowther.com or search for Rae Crowther on YouTube for all of our latest videos...

The sled of the pros. The Classic Two Man Sled (A.K.A. the Pan Sled) is the king of teaching the body mechanics of blow delivery. All of the fundamentals are encompassed in this one sled. The reason so many NFL teams use this sled is its effectiveness. It is a unique design that we started in 1932. You can say it has been around a while, and while it's true that the game has changed, the human kinesiology of bent knees, flat back, short driving feet, and hip explosion all remain the same.



The Crowther gives the player and coach immediate, objective feedback. It allows a player (1 or 2 players) to drive the sled straight when blocked skillfully. The pan base will spin away if hit poorly. Choose your match-ups and place 2 players on the sled and compete. Each player will give 100% effort or he'll get beat by his teammate.

Getcha some knock-back!:

You can't get this combination anywhere else. It makes players bend their knees and use their entire bodies. It teaches lower body mechanics. It incorporates the entire body into the block.



Footwork:

Without good footwork an offensive lineman won't have consistent success. One of the best ways to teach footwork is with the Classic Two Man Pan Sled.

THE CROWTHER PROGRESSION

1. The Pendulum Swing: The pendulum swing teaches offensive lineman to strike a blow. The offensive lineman will be in an upright position with a slight bend in his knees. He then will place his chin slightly over the pad and slightly outside of the pad. Then he will strike the pad with the back of the wrist. He will strike through the pad. As he strikes the pad, the hips will unlock slightly. The opposite arm will reach for the sky, which helps keep the shoulders square.

2. The Triangle: The offensive lineman will remain in an upright position with his knees bent slightly and his weight on the insteps of his feet. The lineman repeats the same motion as in step 1. The lineman will strike through the pad with the back of the wrist as he reaches for the sky, forming a triangle. As the lineman strikes through the pad, his hips will unlock slightly. Remember power comes from the hips. With the opposite arm the lineman will reach for the sky forming a triangle which keeps the shoulders square and creates a big blocking surface. The lineman should strike through the pad with a full range of motion.

3. The Hip Roll: The lineman is arm's-length away from the sled and on his knees. His weight should be back on his heels with his shoulders slightly forward. The lineman will snap his hips through (unlocking the hips and thus generating power) as he strikes the pad at a 45-degree angle. He reaches for the sky with his opposite arm and keeps his head tight to the side of the pad. As the lineman strikes through the pad, the opposite arm will reach for the sky. The lineman will strike through the pad as he did in steps 1 and 2. The hip roll is meant to teach the lineman to punch through the defender (the pad) and snap (unlock the hips). The key terms are reach for the sky and strike through the defender (the pad).

4. The Power Step: Starting from a proper 3-point stance, the lineman will strike the pad with the flipper at a 45-degree angle. As he strikes the pad, he is driving his knee (same foot, same shoulder) through the pad, which simulates driving the knee through the crotch of the defender (one step only). As he strikes the pad and drives his knee through the pad, the opposite foot stays stationary. If the lineman is striking the pad with the right flipper, he will drive the right knee through the pad. If he is striking the pad with the left flipper, he will drive the left knee through the pad. The opposite arm is reaching for the sky. The power step teaches offensive lineman to knock the defender off the line of scrimmage.

5. The Position and Power Step: Starting from a proper 3-point stance, the lineman will take a 6-inch position step (directional step) with his outside foot and then take a power step with his drive leg through the pad (inside leg - same foot, same shoulder) which simulates the crotch of the defender (two steps only). If the lineman is taking a position step with the left foot, the power step is the right foot. If the lineman is taking a position step with the right foot, the power step is the left foot. Make sure the lineman is on the insteps of his feet when working the position, power steps. If the lineman is flat footed he will 'stick and stay' thus becoming unexplosive. The lineman is to strike the defender with the flipper at a 45-degree angle and reach for the sky with the opposite arm. The lineman should feel he is striking the pad up and out.

6. The One Man Drive: From a proper 3-point stance the lineman will work all the components of the drive block. The lineman will position step, power step, and strike a blow at a 45-degree angle through the pad while keeping his head tight to the side of the pad while pumping his outside arm. For a lineman to be successful driving the sled he has to be on the same angle as the sled chassis and maintain his base of support throughout the drive block. The one-man drive is great learning experience for the lineman because it teaches him all the components of a successful drive block.

About the author: Ken Wilmesherr is the offensive line coach at Grossmont Junior College in El Cajon, Calif. In his tenure on the staff of the Griffins, Wilmesherr has developed numerous All-Americans, All-State selections, and All-Conference players. During that period, a number of his linemen have received scholarships to continue their gridiron careers at four-year universities. Wilmesherr has authored numerous instructional articles on various aspects of football play, as well as become a sought-after clinic speaker. To contact him: kenwilmesherr@threecyclemedia.com.

Description	Classic Two-Man Pan Sled with Enduro Pad	Classic Two-Man Pan Sled with Z Pad
Model	MC2R	MC2Z
Price	\$2295	\$2395
Warranty	3 Years	3 Years
Weight	350 lbs.	350 lbs.
Sled Color	Black	Black

Pad Colors	Black	Navy	Royal	Purple	Maroon	Red	Orange	Green
------------	-------	------	-------	--------	--------	-----	--------	-------



Sand bag: Our 85 lb. Sand Bag is made especially for the Classic Two Man Sled. They're made to be placed on the pan base of the sled without falling over. They allow you to place weight in specific areas. Two handles on each bag. A must for collegiate and pro teams.

Model: SB85

Price: \$119

Sled Spins Away



Spins away: If a player(s) hits the sled with poor footwork, it will spin away. As they lose control of the sled, they would lose control of the defender.

Enduro pad or z pad: The redesigned Enduro Pads enhance an ideal shoulder-forearm fit but also provide armpits for a tight hand fit. The pad measures 11" wide.

Drills on line: Watch the entire Crowther progression on-line (www.raecrowther.com) as taught by legendary coach Bobb McKittrick. It starts with forearm delivery, to 6 point explosion, to full body/hip extension, to driving the sled, working right and left shoulders, tight hands, punch explosion, working goal line crab blocks, working the eyes in coming off the sled to linebacker depth, and trapping the sled.

Z LEVERAGE SLED™

Jimmy Lindsey
Defensive Line Coach
Furman University

"Rae Crowther's Z leverage sled really improved our defensive lineman's hand placement. We have the 5 man sled version. Rae Crowther goes above and beyond on what you need as a coach. I would highly recommend Rae Crowther's Z Leverage Sled."

New!

Watch these drills...
Go to raecrowther.com or
search for Rae Crowther
on YouTube for all of our
latest videos...



The New Z Leverage Sled takes training to the next level. Training with the Z Leverage sled is going to make your players stronger and more skillful. The Z Leverage Sled combines a level of skill, strength, and adjustability never seen before in one sled. The side-to-side movement of the leverage arms requires body balance and strength to control and drive the sled. Each arm travels approximately 10 to 12 degrees from center (each arm is limited in travel so that the pads cannot crash into each other). Footwork, good or bad, becomes evident quickly. Players must keep their feet on the ground and maintain their power bases to control and drive the sled. Use the Z Leverage to increase the quality of explosive strength that enables athletes to stay on blocks, get off blocks, or move opponents.

Enhance Footwork & Skill

Poor footwork will be exposed quickly on the Z Leverage Sled and then the sled provides unlimited future lessons each rep to improve that deficiency. Because each leverage arm rises independently, you can see the pad height of each player. No more hiding on a big sled. The design of the leverage arms looks modern but they are designed for functionality. The tube design allows the leverage arms to rest on the ground without the need of a pontoon sticking out into the player's footwork or movement. Each Leverage Arm has 2 levels of height adjustment. You can lock the arm down so that it allows limited leverage, allowing the pad to chest height and no further, or you take the pin out and allow unlimited range to work on full extension. The leverage arm can also be locked from rotating left or right. All of these features can be adjusted individually and are easy and fast to adjust.

Modular Construction

Purchase any size sled and add to it later, or purchase a larger sled and break it down quickly into smaller sleds. With one (1) additional pontoon you can change a larger sled, like a 7 man sled, into a 5 and 2 man sled.

Wide Pad Spacing

The wide pad spacing of the Z Leverage Sled allows realistic lateral movement. Center to center of each pad is 53". The wide spacing allows players to take an offset alignment. With the side-to-side motion of the sled you can work zone concepts. The sled length from back to front is approximately 10'5".

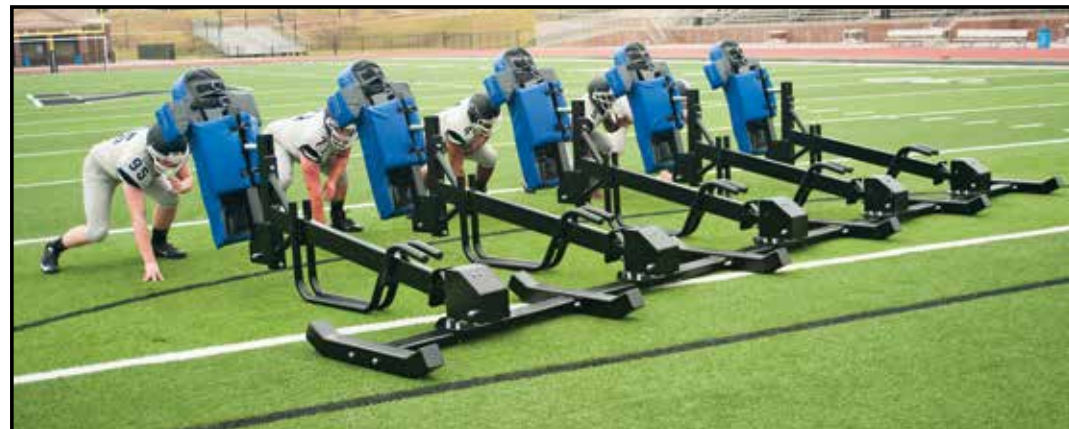

Heavy, realistic, game-like

The Z Leverage Sled will initially expose weakness in a player's skill or strength. For example, if a player lacks upper body strength he might struggle to leverage the pad. Each leverage arm weighs approximately 185 lbs. Obviously it's not easy to leverage an opponent in a game, so for the sled to be effective it needs to be difficult. Each player is lifting a pad against gravity, not an artificial weight that is helped or resisted by a spring. As another example, if a player lacks core strength or lower body mechanics, he will likely struggle to drive the sled squarely.

Pads move left or right / up or down...

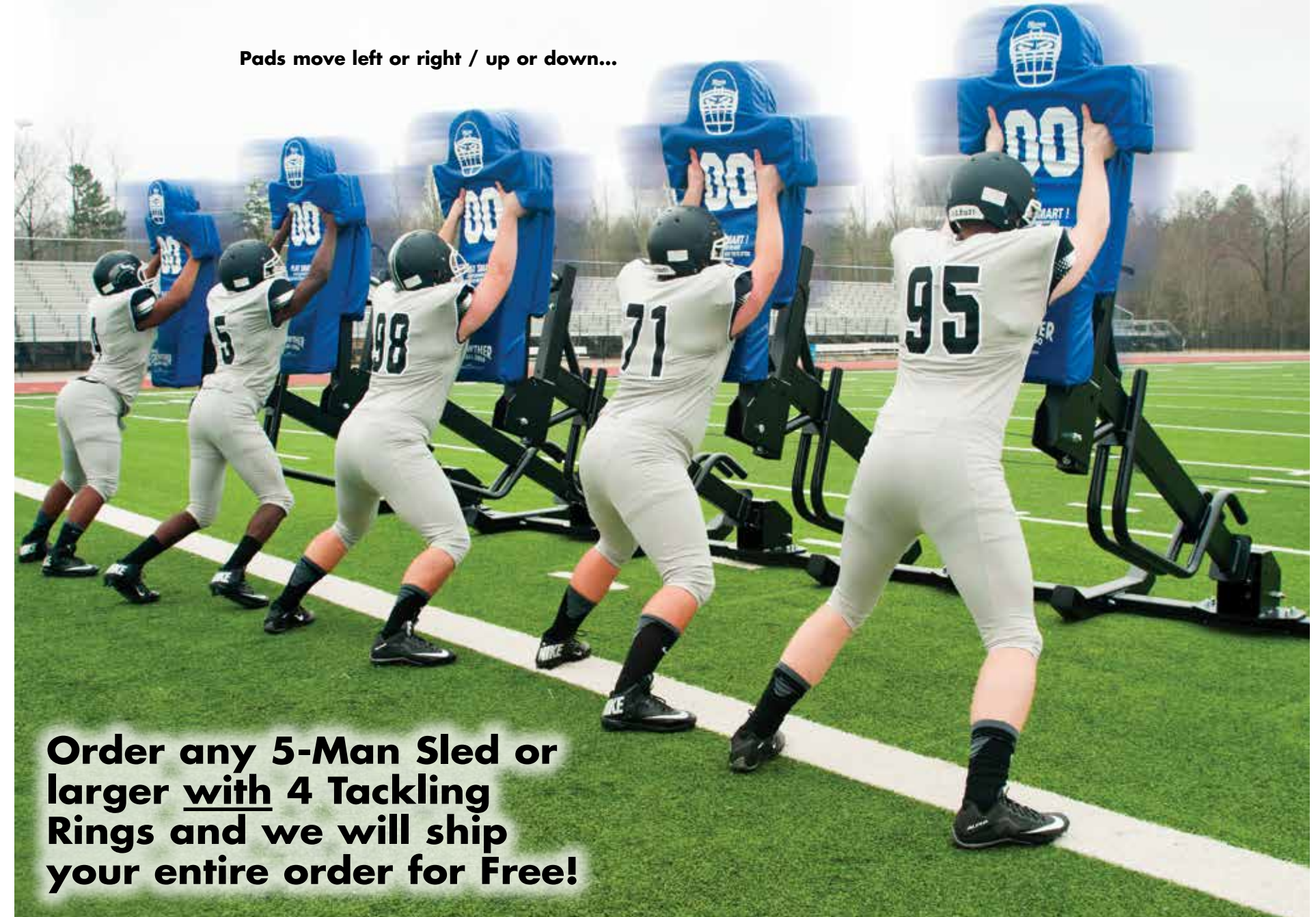

Order any 5-Man Sled or larger with 4 Tackling Rings and we will ship your entire order for Free!

Adjustable Pad Height

Each pad on the Z Leverage is height adjustable (not to be confused with the height adjustment of the leverage arms). There are three (3) pad height adjustments. Each pad can be raised or lowered over 12". The adjustments are in 4" increments. You can raise the pad for pass protection and lower the pad for goal line drills. You can raise the pad for collegiate players and lower the pad for JV players. The leverage arms can be locked down or the pins can be removed allowing the chassis to move side-to-side. The pivot arm height can also be locked down.

The Z Pad

Each Z Pad is attached to a pivot arm. The pivot arm is connected to a coil spring for realistic punching. The Z pads are angled forward to simulate an attacking opponent and thus encourage your players to maintain proper power angles by keeping their knees ahead of their toes. The Z Pad has armpits built into the pad to simulate players. The player's hands fit tight into the armpits. The pad cover is made with 18 oz. nylon and is screened with jersey numbers and a facemask. The pad is made from heavy rebond foam. The pads mount to the sled via two pockets sewn into the pad with 40 oz. nylon and 2" wide gripper webbing. The pads don't twist or turn easily on the pad plate. The pads are easily removable for storage without any need of tools or pins (about 1 minute per pad).

Turf Approved

The flat bottom pontoons, turned up on both sides with no cut holes, won't catch on grass or turf, and the round tubing of the leverage arm will glide over turf or grass.



**Each Chassis has Independent Side-to-Side Movement
+
Heavy Leverage Weight of Each Chassis
=
Strength & Skill Acquisition on the Z Leverage Sled**

Order 24/7 at www.raecrowther.com

Shown Below: An example of a great rep: hand placement, hips, glutes, drive and extension with Lockout Power.



Shown Below: An example of a rep where the players lose control of the sled. Trains lower and upper body mechanics.



MULTIPLE USE SLED

The Z Leverage Sled is many concepts rolled into one sled: It's a traditional drive block sled because you can lock the pad down and use your hands or shoulder. Defenders can work on stuffing blocks, gaining separation, and then escaping. It's a zone block sled because you can hit the pads at an angle. It's a leverage sled because each pad individually rises. It's a goal line sled because you can hit the pads low from a goal line stance. It's an upper body strength training sled because it takes 185 lbs. of force to leverage the pad. It's a lower body strength sled because it takes 300 lbs. of force per person to drive the sled forward. It's a core developing sled because hitting and

controlling the Z Leverage from going sideways takes core strength. Training with reps on the Z Leverage becomes a total body workout. The technique required of a player to generate power and agility can be learned and enhanced through repetitious use of the Z Leverage Sled.



Pad Colors	Black	Navy	Royal	Red	Orange	Green
------------	-------	------	-------	-----	--------	-------

Model: ZL1 (1 Man Z)	Weight: 365	Price: \$1995
Model: ZL2 (2 Man Z)	Weight: 735	Price: \$2995
Model: ZL3 (3 Man Z)	Weight: 1102	Price: \$4295
Model: ZL4 (4 Man Z)	Weight: 1460	Price: \$5695
Model: ZL5 (5 Man Z)	Weight: 1837	Price: \$6995
Model: ZL6 (6 Man Z)	Weight: 2190	Price: \$8395
Model: ZL7 (7 Man Z)	Weight: 2555	Price: \$9795

New!

Watch these drills...
Go to raecrowther.com or search for Rae Crowther on YouTube for all of our latest videos...



**S-ADVANTAGE™
2-7 MAN SLEDS**

US Patent #6,988,965 B2
US Patent #6,942,585 B

Craig Cansler
Offensive Line Coach
Eulless Trinity High School
3-Time 5A State Champs

"We have a Crowther S-Advantage Sled with Hit-Tech Leverage Mechanism. This sled plays a big and important part in our individual period. Our offensive linemen get ample reps on the sled working both hand and shoulder drills. The S-pad forces players into the proper blow delivery position with low hips and finishing the block. We work all of our zone steps on the sled. I can honestly say to you, if you're looking for a new sled, the S-Advantage is the right choice."

New!

Watch these drills...
Go to raecrowther.com or
search for Rae Crowther
on YouTube for all of our
latest videos...



Play with leverage: low man wins. Bent knees, flat back, tight hands and choppy feet (or if you prefer, a near perfect shoulder - forearm fit). Just a few things that describe what the S-Pad is designed to do. As you know, the laws of physics dictate that the low man wins. It's hard to hit the S-Pad high. Some coaches think the S-Pad is like having a chute attached to their sled.



Run through frame:

Your players can run through the frame of the sled. This is possible because there's only one connector link between each pad, and the link is just above the ground. The sled also provides wide 56" center-to-center pad spacing.



Goal line situations:

Because the S-Pads extend close to the ground, you can work crab blocks and goal line situations. Each pad is removable for storage. To remove, you unzip the pad and unlock the Velcro straps. The S-Pads are the only pads we know of with a two-part protective cover.



Heavy duty construction:

Work traps, pulls, downblocks or virtually any combination on the S-Sleds. We believe in heavy steel construction. To maintain a power base, your players need a heavy sled that resists. Each person is in essence driving 240 lbs.



Pass pro & linebacker drills:

Work Pass Pro drills or defensive punch techniques on the S-Pads. The curved S-Pads will force players to bend their knees. For big results an S-Advantage Sled is the right choice for your team. Even players tell us you can't cheat the S-Pads.

Frank Garcia, Retired NFL Lineman - 10 Year Veteran

O-Line Coach Charlotte Catholic: 2AA State Champs '04, 3AA State Champs '05, 3AA State Runner-Up '06

"The 5 man sled has been an integral part in the development of our young men. We run a wing-T offense that is based on a quick hitting attack style O-Line play. We start every individual drill by hitting the S-Advantage Sled. At every level of play from high school to the pros, I have always used a sled to help develop technique. The S-Sled simulates the most realistic block faced in game situations. There is no doubt that without the S-Sled we would not be as successful as we are today."



A sled for all techniques, defensive and offensive:

Control the trenches and impose your team's will. Play with leverage. The S-Advantage Sleds are built and designed for virtually every position. They are equally as effective for DLs as OLs, for RBs and LBs, and for DBs and TEs. You can practice and improve all of your blocking techniques. The sled works for hands, punch, forearm, shoulder, rip, and swim. No other sled has that many options. An S-Advantage sled is like four sleds in one.



Tight hands or shoulder block:

No matter what the technique, the S-Pads are an ideal fit for defensive and offensive linemen. When using the hands, they have to make a tight fit. They can strike with their thumbs up or in joint alignment. See the optional Hit-Tech Mechanism on page 18 for locking out. For shoulder-forearm blocking the pads also make an ideal fit. The players get a realistic feel for driving their opponents out of their stances.

OPTIONAL DUAL ARM S PADS:

The Optional Dual Arm S-Pads take sled effectiveness to the next level. These pads are the most effective pads to train inside hand placement. Each rep with the Dual Arm Pads is more game-like as it requires more concentration and skill from the players. Hands too high or too wide simply get blocked by the arms, making it more difficult to drive or punch the sled. The benefits of the pad for rip and swim techniques are great. The arms are made of dense foam so they will move when hit, but not too easily. Being low is an absolute prerequisite to hitting this pad; a player can't stand up and get a proper fit underneath the armpits. The pads also make a fine target for forearm - shoulder blocking.



OPTIONAL HIT-TECH LEVERAGE MECHANISM:

Hit on the rise. 95% Of all s-sleds are ordered with this option:

- The Hit-Tech (the yellow-circled breadbox-looking mechanism shown below) option allows each player to leverage his pad from a starting position to an upright position, where the chest of the pad is nearly perpendicular to the ground. The pad leverages (rises) on a realistic angle (particularly important for OLs and DLs to punch out, and not just up). It doesn't leverage straight up or straight back but rises like a player coming out of his stance.
- The Hit-Tech helps teach violent hands or shoulder skills. As you leverage the pad, it becomes more difficult to raise, and you encounter more resistance than just the weight of the pad. The force required to leverage the pad is 189 lbs. per inch (plus the 90 lb. weight of the pad plate). This encourages players to bring their hips through their blocks. The pad doesn't superficially unlock at a certain point and become lighter. Thus, there's resistance to the players at all angles. This is particularly important for DLs to gain the strength to lock their elbows out against a strong opponent. The higher the player leverages the pad, the more it resists.
- Each player leverages his own pad. Nothing particularly new here, except it's a lot easier on the Crowther Hit-Tech system to "see" each player's effort because of the wide pad spacing and shape of the pad.
- The most overlooked benefit of the Hit-Tech system is its simplicity. There are no latches to break and no roller bearings or gas shocks to replace. It's professionally engineered. It consists of a 10" zinc coated coil spring, a metal spring plate, a metal box, and bolts.
- Simple. Good. Durable.

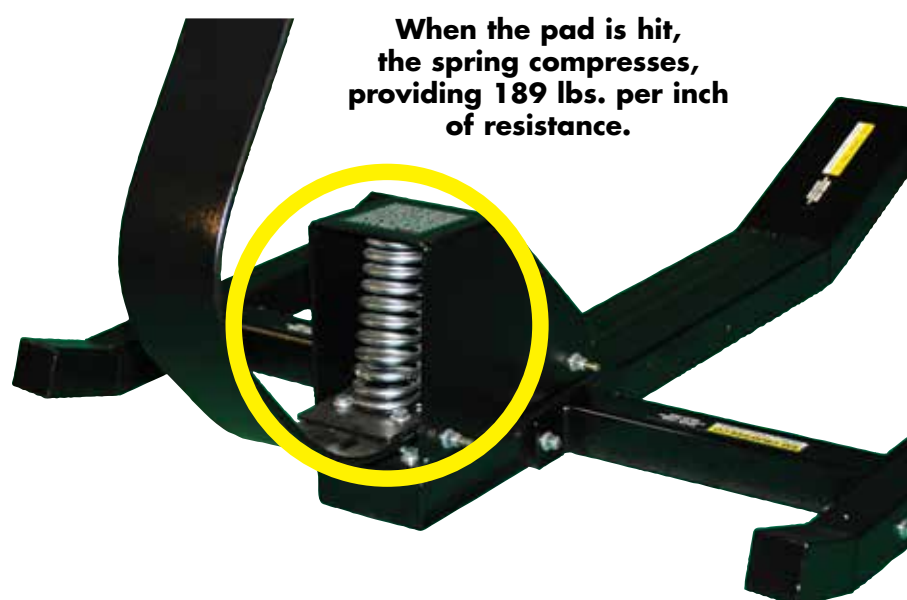

Order 24/7 at www.raecrowther.com

JV S-Advantage Sleds	2 Man	3 Man	4 Man	5 Man	6 Man	7 Man
JV S-Sleds (for player sizes 95 - 160 lbs.)	\$1845 Model: 2ADVJ	\$2645 Model: 3ADVJ	\$3345 Model: 4ADVJ	\$4245 Model: 5ADVJ	\$4945 Model: 6ADVJ	\$5845 Model: 7ADVJ
JV S-Sleds with Dual Arm S Pads (for player sizes 95 - 160 lbs.)	\$1945 Model: 2ADVJD	\$2745 Model: 3ADVJD	\$3545 Model: 4ADVJD	\$4445 Model: 5ADVJD	\$5245 Model: 6ADVJD	\$6245 Model: 7ADVJD

Varsity S-Advantage Sleds	2 Man	3 Man	4 Man	5 Man	6 Man	7 Man
Varsity S-Sleds (for player sizes 160 - 275 lbs.)	\$2045 Model: 2ADV	\$2945 Model: 3ADV	\$3845 Model: 4ADV	\$4745 Model: 5ADV	\$5545 Model: 6ADV	\$6345 Model: 7ADV
MOST POPULAR CHOICE: Varsity S-Sleds with Hit Tech (for player sizes 160 - 275 lbs.)	\$2395 Model: 2ADVH	\$3395 Model: 3ADVH	\$4395 Model: 4ADVH	\$5495 Model: 5ADVH	\$6495 Model: 6ADVH	\$7495 Model: 7ADVH
Varsity S-Sleds with Hit Tech & Dual Arm S Pads (for player sizes 160 - 275 lbs.)	\$2495 Model: 2ADVHD	\$3495 Model: 3ADVHD	\$4545 Model: 4ADVHD	\$5675 Model: 5ADVHD	\$6745 Model: 6ADVHD	\$7745 Model: 7ADVHD

S-Pad Colors	Black	Navy	Royal	Purple	Maroon	Red	Orange	Green
--------------	-------	------	-------	--------	--------	-----	--------	-------

Dual Arm S-Pad Colors	Black	Royal	Red	Green
-----------------------	-------	-------	-----	-------



Order any 5-Man Sled or larger with 4 Tackling Rings and we will ship your entire order for Free!

**SHOCKWAVE
LEG CHARGER SLED™**

Mike Srock, Speed and Strength Coach, James F. Byrnes High School State Champions '02, '03, '04, '05, '07, '08

"An awesome piece of equipment! As part of our in-season program our OL/DL and LBs are doing 4 sets of 4 reps twice a week. Position coaches have noticed a tremendous increase in explosive power. OL coaches have also mentioned that hand placement has improved, as well as ability to stay on the block longer. The Shockwave will be a HUGE part of our off-season program."

"WITH THE SHOCKWAVE IN OUR WEIGHT ROOM, IT DOESN'T MATTER IF THERE IS 2 FEET OF SNOW OR IT'S 105° OUTSIDE; WE GET BETTER AT FOOTBALL YEAR ROUND"

Skill transfer - functionally strong for football. Where strength collides with football: gain thousands of football specific repetitions. Increase the quality of explosive strength that enables athletes to stay on blocks or make tackles. Challenge your players to break the stalemate at the line of scrimmage. Get stronger and faster in an absolutely football specific position year round. Hit the pad and drive it up the incline. Develop an explosive force that moves opponents, and because the machine is plate-loaded, you can increase resistance as the athletes improve. The Shockwave works the transition zone between hitting a target and moving a target. Increase the quality of explosive strength that enables athletes to stay on blocks or make tackles. The Shockwave can help develop lean athletic players who can play with low pads and leverage and exert force in the desired direction. This is about creating football strength. And the sled ships free! (A \$500 value.)



932 lbs
Sled Weight

PRACTICE TECHNIQUE



GAME TECHNIQUE



Pad can travel left & leverage...



Pad can leverage or lock-down...



Pad can travel right & leverage...

PAD ARM LEVERAGES AND PIVOTS UP, DOWN, LEFT, & RIGHT:

The pad leverages up (or locks down if you wish) and also, importantly, the pad arm pivots right or left (which can also be locked in place for beginning athletes or rehab). The pivoting arm requires body balance from the player, which in return requires more muscles to fire and thus control the pad. Not just the pad pivots, but the entire arm, which makes a big difference because it makes it much harder for the player. Hitting and driving the Shockwave for reps becomes a total body workout. The kinesiology required of a player to generate power and agility can be learned and enhanced through repetitious use of the Shockwave. The Shockwave is more of a free weight machine than any other leg drive machine. You can add up to 540 lbs. of additional weight to the chassis carrier and add up to 210 lbs. of additional weight to the leverage arm itself (resistance to leveraging the pad). Thus, the Shockwave is adjustable for all levels of play. By inserting the Shockwave into your workout schedule, you will see results on game day.



"Condition the bones, tendons, ligaments, and muscles to withstand and overcome the high forces placed on them in the demands of competition."



Choose between the standard Enduro Pad or the Optional Z Leverage Pad shown on left.

7' Shockwave (with Enduro Pad)	7' Shockwave (with Z Leverage Pad)
Model: SWV7	Model: SWV7Z
7' L x 56" W	7' L x 56" W
Black Chassis	Black Chassis
932 lbs.	932 lbs.
Price: \$3695	Price: \$3795



New!

Watch these drills... Go to raecrowther.com or search for Rae Crowther on YouTube for all of our latest videos...



**TACKLE-BREAKER
SLEDS™**

US Patent #6,988,965 B2
US Patent #6,942,585 B

Full speed drills. It's goal line territory... Go to your beast; your heavy artillery! Run the ball effectively out of 2 back, 1 back, shotgun sets... If there is one statistic that shows how tough or physical a team is, it's rushing yards and/or rushing yards allowed. The Tackle-Breaker is unique and unlike any other running tunnel. Break through the arms of the Tackle-Breaker and gain extra yardage! By generating enough force to break open the arms of the Tackle-Breaker, your players gain hundreds of first down generating repetitions. Each Power-Arm simulates not just stripping the ball but making a tackle. The Tackle-Breaker reduces the risk of injuring a live tackler and ball-carrier. It trains players to lower their shoulders and maintain leg drive. It enhances toughness to take on tacklers physically larger. The more repetitions a player gets with the Tackle-Breaker in practice, the more tackles he can break during the game. Only the Tackle-Breaker simulates the arms of six actual tacklers. The player must generate approximately 200 lbs. of force to break the arms open and escape. Each Power Arm measures 19" long x 8" wide x 5½" thick. Each Power Arm has a 4" overlap. Your players will have to be explosive into the arms, break them open, and maintain body lean. The power arms grab the ball carrier and force him to concentrate on ball security, body lean, pad level, and sustaining leg drive. All models come with adjustable height arms, to allow you to set the height of the sled to match your players. To adjust the height of the arms, simply unbolt four bolts and adjust the arms up or down. There are 10 hole adjustments on 2" centers, allowing 18" of pad height adjustment. Order all of the options and we will ship the sled free!

TACKLE-BREAKER SLED
Model: TBSV100 Price: \$2195

Pad Colors Royal Red Green Black

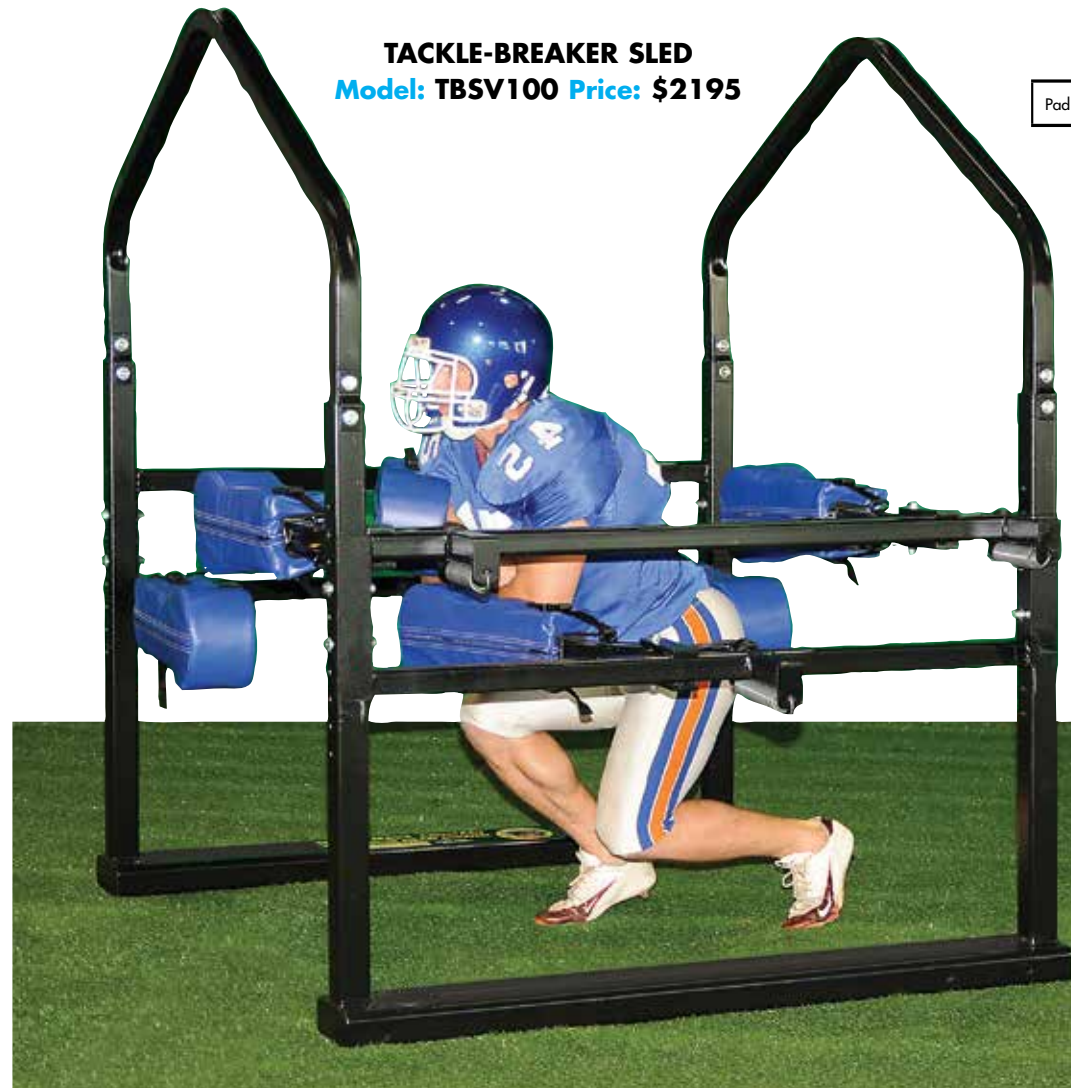

Order 24/7 at www.raecrowther.com

OPTION 1: SWINGING DUMMY (75 LBS) WITH METAL BEAM SUPPORT. Model: TBS1 Price: \$595

Swinging Dummy (75 lbs.) with Metal Beam Support. The Swinging Dummy can be used for stiff arm, forearm, collision, and evasion drills. The moving bag makes running through the TBS harder and more realistic. Use with OL's and DL's for punching. Crowther uses a special blend of foam to give the bag a dense-life like feel that also keeps the bag durable. Hangs from heavy webbing and chain and is supported by a large metal beam for strength. The bag doesn't lose its shape. Heavy duty Industrial clasp connects the bag and beam. The Bag is not filled with sand and will not leak. Warranty: 3 year factory warranty.

OPTION 2: S PADS WITH HIT-TECH LEVERAGE SYSTEM (2 PER SLED). Model: TBS2 Price: \$1895

S Pads with Hit-Tech Leverage System. The S Pad Option with Hit-Tech Hit turns your TBS into a 2 man sled. Use with all players. Hit and spin, drive, or tackle. Use with 1, 2 or 3 players simultaneously. The S-Pad has a head, torso, waist, and knees. It represents the look of a player in motion, not standing still. Pads are removable for storage. The Hit Tech allows each player to leverage his pad from a starting position to an upright position, where the chest of the pad is nearly perpendicular to the ground. All metal parts are powder coated black. Weight: 224 lbs. Warranty: 3 year factory warranty.

OPTION 3: WHEEL KIT (2 PER SLED). Model: TBS3 Price: \$295

Wheel Kit for Tackle Breaker Sled. Use the wheel kit to move your sled around the field when the grass is worn out or mowing. The Wheel Kit slides over the frame uprights of the sled and pins in place with a hitch pin. Includes 2 foam filled "Never Flat" wheels for moving sled. Weight: 75 lbs. Warranty: 3 year factory warranty.

FREE SHIPPING!
Order all of the
options and we
will ship your
sled for free!



FAX: 803-366-3633

Call Toll-Free: 800-841-5050

New!

Watch these drills...
Go to raecrowther.com or
search for Rae Crowther
on YouTube for all of our
latest videos...



LEVERAGE CUBE

To successfully drive and flip the Leverage Cube and sustain movement athletes must lower their center of gravity and maintain a strong back angle while their hands and feet coordinate. As the Cube "flips, or turns over" the players can then re-strike the cube and repeat. The players must constantly reposition their hands and keep their legs driving. All of this adds up to better pad level skills, foot drive, hip/leg drive, hand placement, and arm extension.

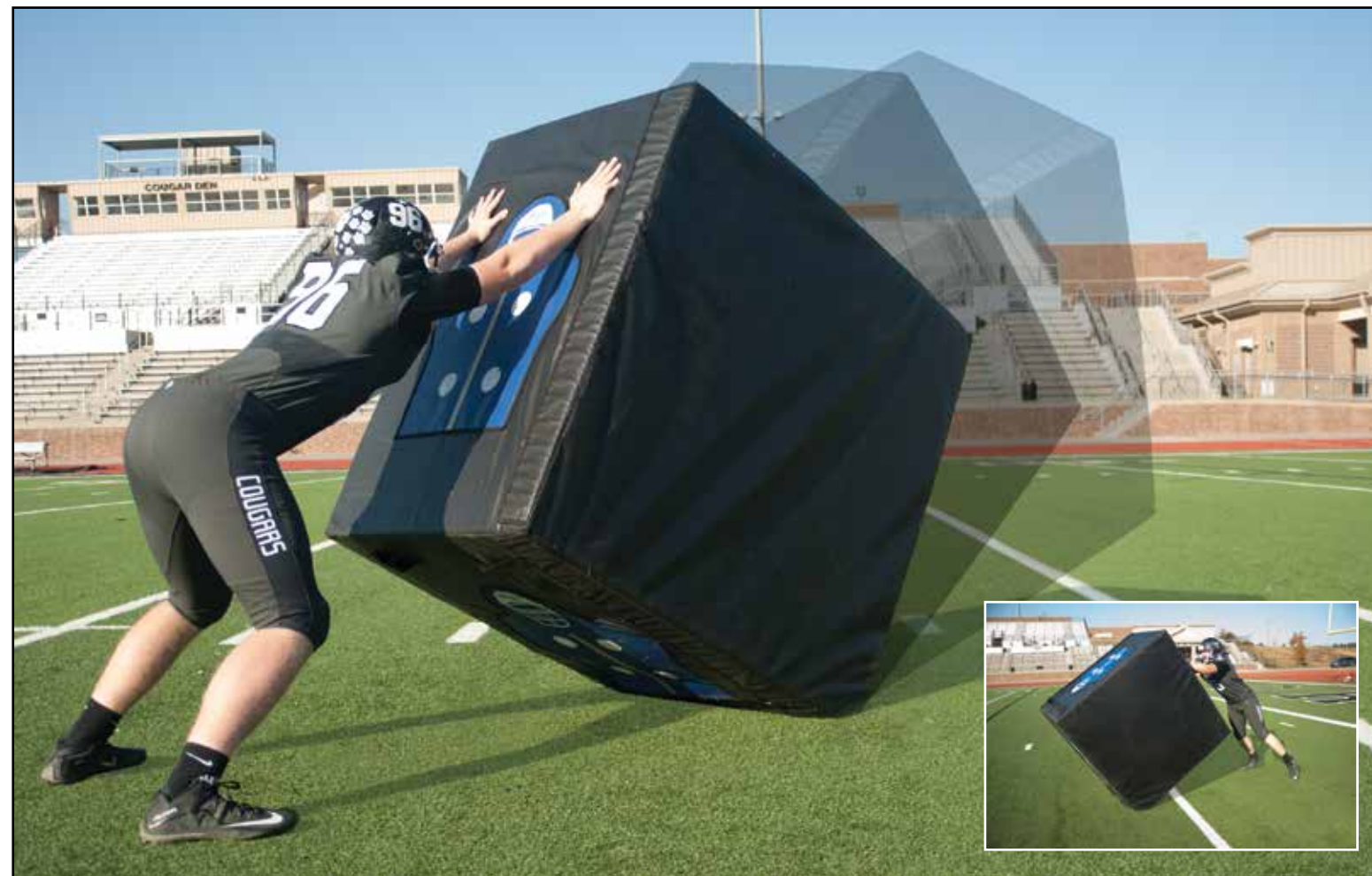

LEVERAGE CUBE

This is a new and unique piece of practice equipment. The Cube is rectangular, made with dense foam, and heavily weighted in the center with sand (typically 200-600 lbs.) The Cube is an excellent tool for indoor and outdoor use. On all 4 sides of the cube the player is presented with a Player Target that is sewn onto the vinyl for durability. The players push and leverage the cube until they "push it over." The shape and weight of the Cube creates the right amount of leverage and forward push. The Cube helps create stronger players. As the athletes become fatigued they are faced with the challenge of remaining in a strong athletic position and keeping their legs and hands driving. The amount of ballast in the center of the Cube is adjustable. We recommend varsity level teams start with around 300 - 500 lbs. of sand but you can place up to 800 lbs. Why not have a few Leverage Cubes in your gym this winter and use all spring and summer outside? An optional weather cover is available extending the life of the cube by keeping birds, rain, and sun off the vinyl. The Cube ships with a special plastic palette that is weather resistant and won't rot, split or mildew, to store the cube when not in use outside keeping the Cube off a rain soaked field. Cube size is 53" diameter x 36" wide. Ships motor freight. Warranty 2 years.

Model: LC-R Leverage Cube - Black with Red Icons (sand not included)
Model: LC-RS Leverage Cube - Black with Red Icons (with 500 lbs. of sand)
Model: LC-B Leverage Cube - Black with Royal Icons (sand not included)
Model: LC-BS Leverage Cube - Black with Royal Icons (with 500 lbs. of sand)

Price: \$1195
Price: \$1395
Price: \$1195
Price: \$1395



Play With Violent Hands:

The DFR is no gimmick. It's old school. The Crowther Defensive Reaction Machine can help your players get off blocks and get to the ball carrier quickly. It can help develop the necessary skills required for successful defensive line play, such as quick reactions, good footwork, playing low, and powerful hands. Drills can be run quickly.

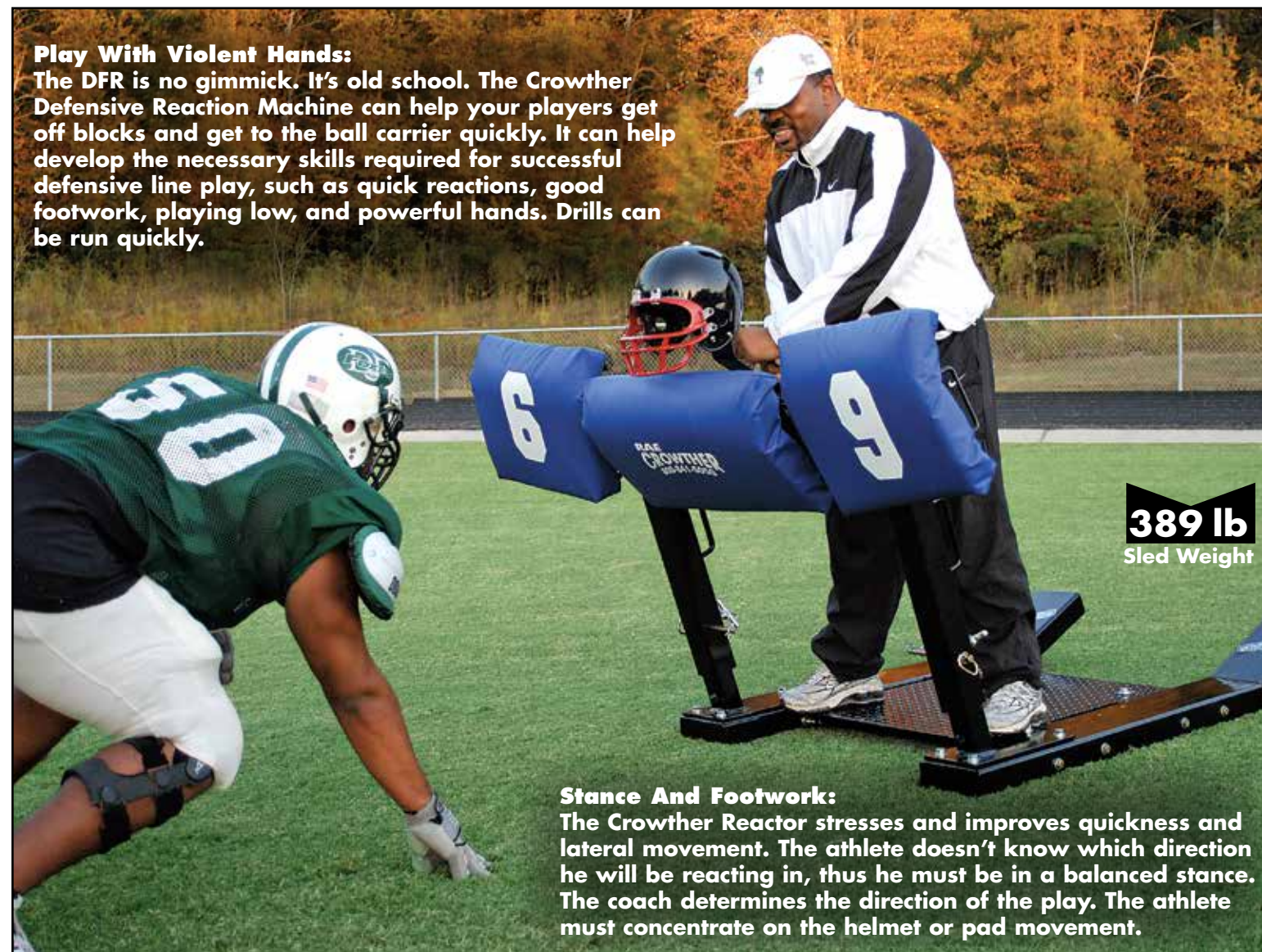

Stance And Footwork:

The Crowther Reactor stresses and improves quickness and lateral movement. The athlete doesn't know which direction he will be reacting in, thus he must be in a balanced stance. The coach determines the direction of the play. The athlete must concentrate on the helmet or pad movement.

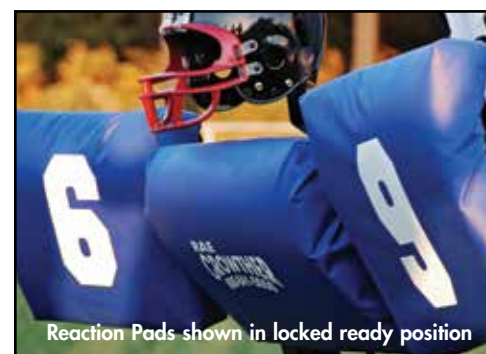

Reaction Pads shown in locked ready position



Left wing pad fired



Strike the pad and lock it back into position

DEFENSIVE REACTION MACHINE

US Patent #3,062,547

Fast Firing Pads:

The Crowther pads fire fast and lock consistently. There's no waiting. That comes from rugged construction and quality materials.

Helmet Movement:

The Crowther Reaction Machine is the only machine with helmet movement. Slide the helmet left, and the left wing pad fires. Slide the helmet right, and the right wing pad fires. This action gives the defender a good feel for an attacking lineman and the direction of the play. If you employ a reading defense, this is a nearly perfect machine for you.

Height Adjustability:

You can easily adjust the pads from pass-pro to goal-line height by removing two pins and raising or lowering the top chassis.

Model: DFRR

Price: \$2295

Pad Colors

Red
Royal
Black

GROUND BATTLE CHUTES™

Mike Armstrong
Offensive Line Coach
Spring Valley High School

"Successful line play, offensively and defensively, involves low pads, leverage and proper technique. When a lineman is performing at a low pad level for an extended distance, any technique deficiencies he possesses will be detected. Most chutes are short and narrow and limit movement. This is why the Ground Battle Chute is the largest and most versatile chute on the market. This chute is wide, long, adjustable, and safe and has no inner supports that inhibit lateral or diagonal movement. Whatever your blocking scheme, trap, zone, counter, combo or fold, this chute will accommodate your team."

New!

Watch these drills...
Go to raecrowther.com or search for Rae Crowther on YouTube for all of our latest videos...



900 lbs

Order any size Ground Battle Chute with 5 or more Chute Boards and we will ship your entire order for free

Stay Lower Longer. Shown: 27' x 12' ground battle chute
Does not tear up expensive helmets like standard metal chutes.

Keeping Multiple Players Low

In general, the Ground Battle Chutes are designed to keep players low and maintain a good football position while moving. If your goal is to train as many athletes as possible, in as many varied drills as possible, and in the shortest possible time - then you have found the perfect chutes! The angled legs of the chutes allow more room. Each leg doesn't go straight down. This, in effect, increases your workable space under the chutes. Players can exit the chutes from every angle, including through the legs.

The Frame Adjusts Up, Down, Or Angled:

You can adjust the height or angle of the chutes. The height is adjustable from approx. 63"- 60"- 57"- 54"- 51"- 48"- 45". You can adjust the angle of the frame to various degrees.



More Of Your Drills In Less Time:

Of course your OLs and DLs can work all their techniques, drive blocks, angle blocks, double teams, pull blocks, hook blocks, long and short trap blocks, and cross blocks. But that's just the beginning.

Large Chute Sizes:

The 36' x 6', 27' x 12', and 27' x 6' are large enough to run just about any drills for any position. Think DLs, DBs, RBs, WRs, and even QBs. The 27' x 12' is wide enough to allow 2 opposing rows of players to work drills simultaneously in different directions.

Wheels Are Standard Feature:

Every Crowther chute comes with 8 standard wheels. And, each wheel is foam filled (not pneumatic); thus, it will never go flat. For teams that have to maneuver their chute through narrow openings we also offer optional caster wheels.



Low Man Wins... 27" x 6" Ground Battle Chute

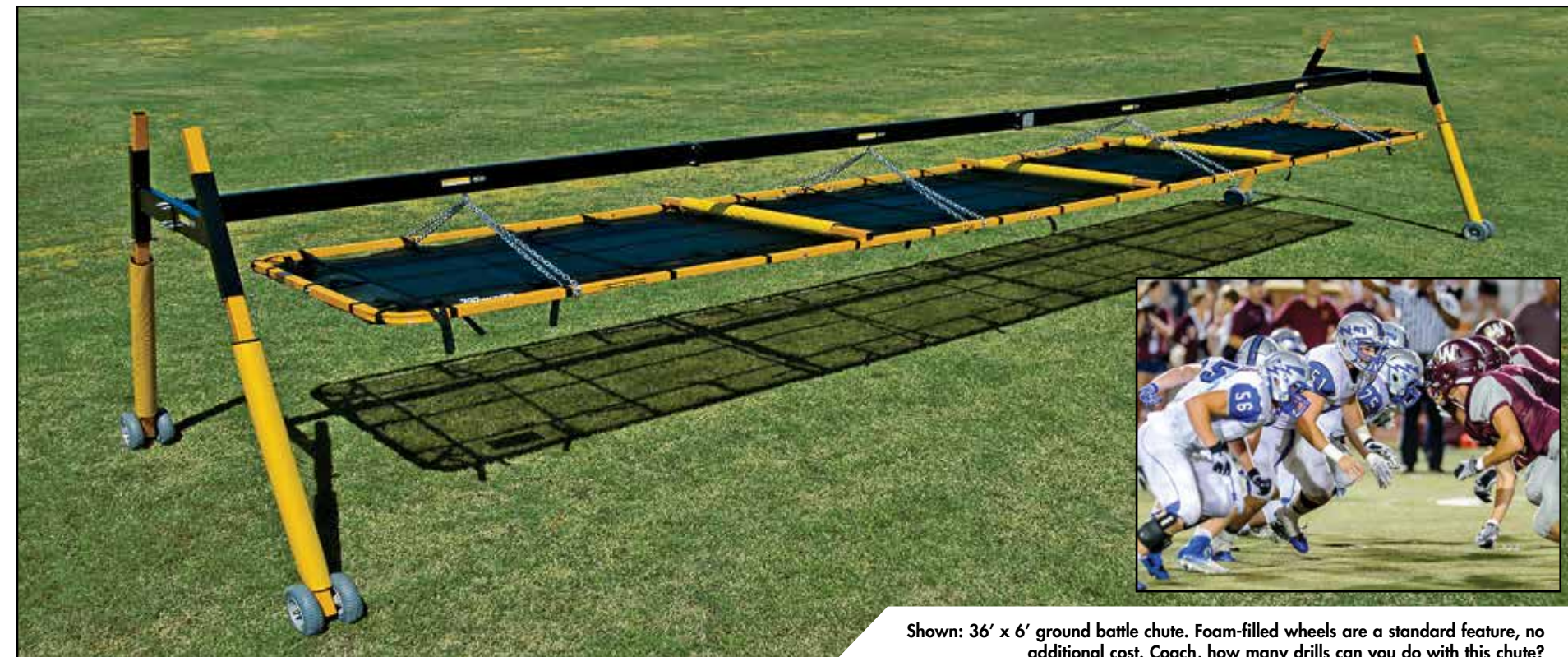

Shown: 36' x 6' ground battle chute. Foam-filled wheels are a standard feature, no additional cost. Coach, how many drills can you do with this chute?



Shown above: 18' x 6' Jam Tent. The angled legs on the Jam Tents and Ground Battle Chutes create more under the netting than any other chutes.

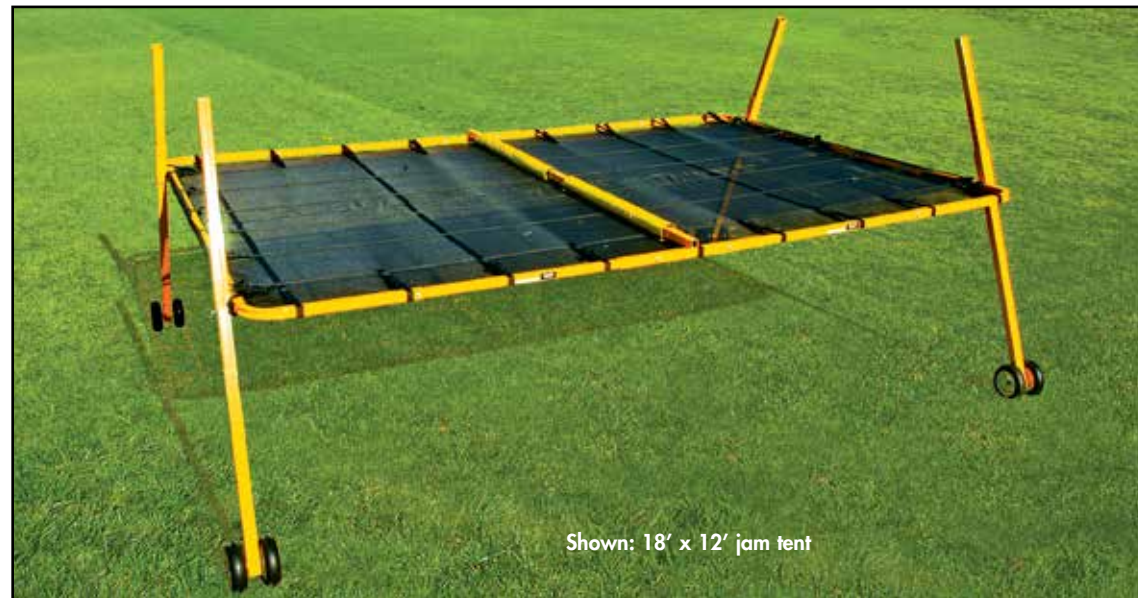

Shown: 18' x 12' jam tent

Jam Tents:

Jam Tents are our smallest chutes. Because of their smaller size, Jam Tent frames do not hang from a center beam like Ground Battle Chutes, otherwise they are identical.

Sizes available are 12' x 12', 18' x 6' and 18' x 12'.

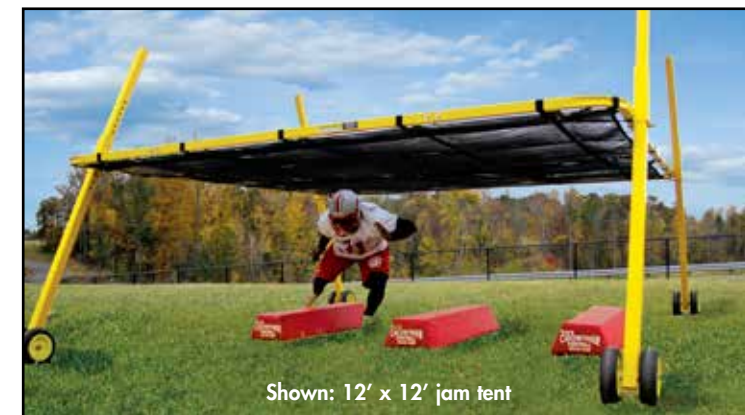

Shown: 12' x 12' jam tent



Shown: 27' x 6' Ground Battle Chute. Adjust the height of the Ground Battle Chute by sliding the legs up or down.

Combination Metal And Mesh Net:

Each Ground Battle Chute has a combination of metal square tubing and mesh netting for its frame. The obvious benefits are weight savings, improved safety when a player rises up, and fewer scratched helmets. This saves the player and the helmet. The not so obvious reasons are durability and adjustability. The netting has webbing sewn into it horizontally and vertically. It is very strong. When your season is complete, you unsnap the netting and bring it indoors. Simple.

Crane Construction:

The problem with traditional chutes is the longer you make them, the heavier they become, and the more apt they are to bend or bow. The Ground Battle Chutes solve this problem in two ways. First, we suspend the frame from a crane platform that is strong. Then, we use a combination of metal tubing and tough outdoor mildew-resistant mesh netting for the frame.

***Note: All chutes come standard with 8 foam-filled (no flats) fixed wheels.**

Description	12' x 12' Jam Tent	18' x 6' Jam Tent	18' x 12' Jam Tent	27' x 6' Ground Battle Chute	27' x 12' Ground Battle Chute	36' x 6' Ground Battle Chute	Four Chute Leg Pads	Optional Caster Wheels*
Model #	12GBC	18GBC	18XGBC	27GBC	27XGBC	36GBC	GBCLP	GBCCW
Price	\$1495	\$1695	\$2095	\$2795	\$3195	\$3695	\$295	\$449
Warranty	3 Years	3 Years	3 Years	3 Years	3 Years	3 Years	3 Years	3 Years
Weight	312 lbs.	477 lbs.	585 lbs.	695 lbs.	918 lbs.	998 lbs.	20 lbs.	20 lbs.

CHUTE STALLS



Chute Stalls are modular and can stand alone as single units.

FIRE OUT:

Players can't rise out of their stance without hitting the top of the chute stall. Thus, this will reinforce knee and ankle bend out of the stance. Each stall is fully modular. If desired, each stall can stand alone. Assembly is simple. Each stall is made of 1 1/2" square tubing. The benefits of square tubing are more stable construction and durability. The stall height starts at approx. 45" and climbs to 52". Each stall is 54" wide and 60" long. They are also an excellent choice with the chute boards featured below.

Description	1 Man Stall	2 Man Stall	3 Man Stall	4 Man Stall	5 Man Stall	6 Man Stall	7 Man Stall
Model #	1STA	2STA	3STA	4STA	5STA	6STA	7STA
Price	\$349	\$650	\$975	\$1299	\$1625	\$1950	\$2275

Watch these drills...
Go to raecrowther.com or search for Rae Crowther on YouTube for all of our latest videos...

CHUTE BOARDS

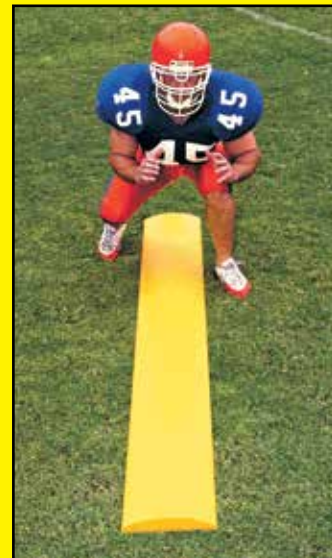

CHUTE BOARDS

The most indestructible boards in the industry! 8' long x 12" wide x 2" height, these hard plastic boards are molded in a half moon shape with a beveled edge. These boards won't crack like traditional rubber boards. Heavy, 50 lb weight per board keeps the board in place during your drill work. With the longest warranty in the market, 5 years, the Crowther Board is an easy decision. Rain, snow, or water, even the lawn mower can't destroy these boards. The boards are molded in yellow.

Model: CGLX **Price:** \$175
Order 5 or more and save 10% (\$157)

MONSTER RUNNING ROPES™

The Monster Running Rope is a height-adjustable running rope. It is 6' wide (most ropes are 4') and this places the metal farther away from contact with any players. A flat bar connects the two chassis. Players can work quick starts, high knee lifts, or various other drills. Easily adjust the rope from 7" to 17" for specific position drills. The rope is made of high visibility yellow heavy duty nylon webbing. 16 squares per rope. 25.5" foot hole size. 19 foot length. Weight: 125 lb.

Model: MRR1 **Price:** \$485

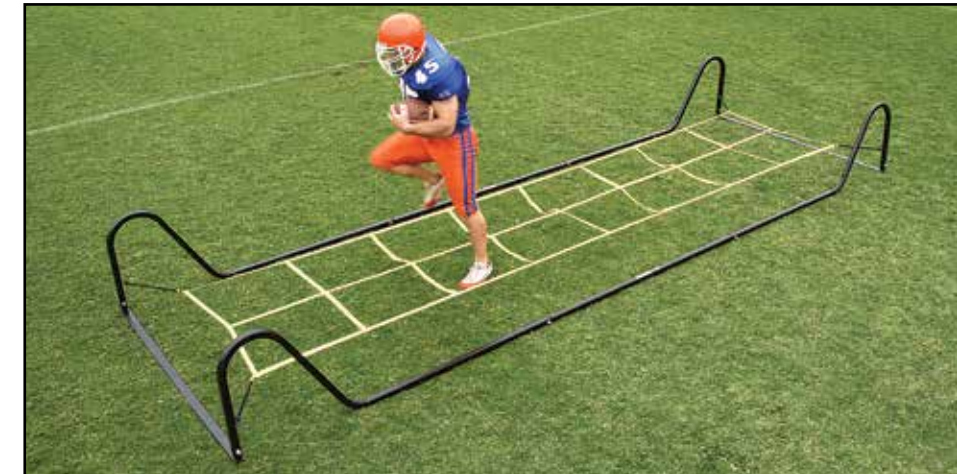

REPLACEMENT ROPE WEBBING

Replacement Webbing fits the Rae Crowther Monster Running Rope. Complete nylon rope assembly includes bungee cords for attaching rope to metal. Rope is approx 19' in length. Foot hole size is approximately 25". 16 squares per rope. All ropes come in high visibility yellow. 2 year warranty.

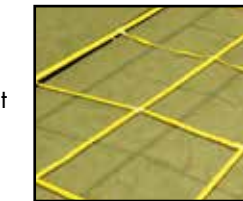

Model: MRR2 **Price:** \$115



RUNNING BACK ARCH

Make Running Backs into smaller targets. Increase their hitting power. Work the posterior chain. Practice and repeat the specific footwork required to make plays successful. Enhance change of direction and explosiveness. Made from square tubing. Portable. Stable. Powder coated in black. 55" tall x 37" wide x 43 lbs.

Model: RBA1 **Price:** \$205
Order 2 and save 10% (\$184)

METAL AGILITY LADDER

Foot fire! The Metal Agility Ladder is similar to the traditional foot ladder but is made from metal so that it will not kick out of place. The Metal Agility ladder is light enough to transport but heavy enough to stay in place. The Ladder measures 19' long (you can add to that length if you desire with individual sections) . Comes in 4 sections that slide together for easy shipping, travel, and set up. The metal squares are 1/2" tall, so it can be used with sneakers or cleats. Keep the ladder inside or outside. Order in quantity and save. Each section is 4.75 feet long (57). Each foot hole is 19" x 19". Powder coated yellow. Weight 6 lbs. per piece, 24 lbs. per ladder.

Model: GPR1 **Price:** \$199

Order 2 Ladders and save 10%. **Price:** \$179

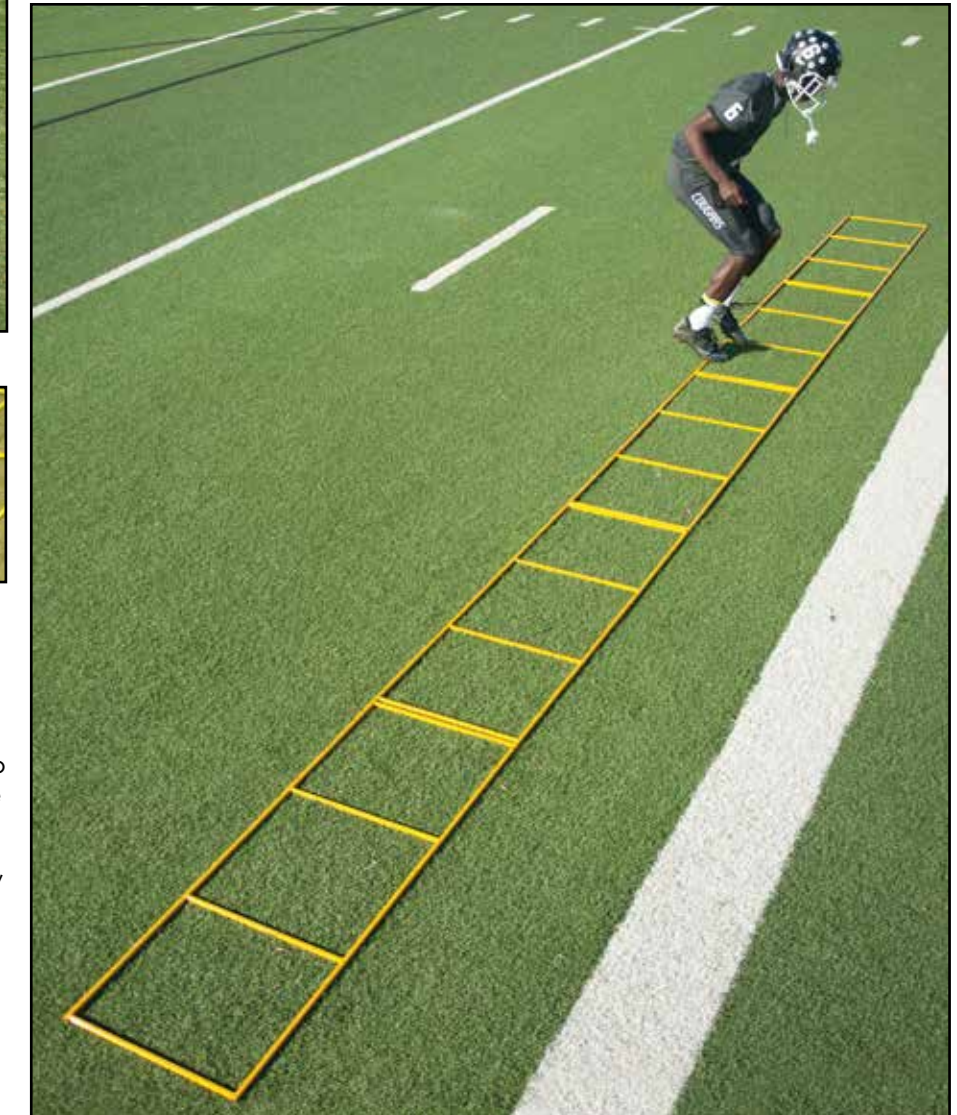

QB PASS RUSH NET

Ken Dorsey
NFL QB Coach

"The QB Pass Rush gives QBs a great simulation of a Game Rep more so than anything you could do on air. It makes throwing routes to receivers more realistic for the QB by simulating the Lines in front of him. It helps drill Pocket Feel and Mobility more so than on air, and gives him a feel of live rushers because of QB Pass Rush's ability to move in all directions. There are so many different ways to use QB Pass Rush and benefits from using it. Benefits ranging from Pocket Feel, Vision work, Anticipating Windows, Fundamental Drill Work and throwing the ball with Arc Over the Top or through Windows. It is a great tool to improve so many aspects of a QB's game."



QB PASS RUSH NET

The QB Pass Rush Net is designed to enhance a QB's footwork, pocket pressure, pocket vision, throwing accuracy, ball trajectory...and a lot more. The QB Pass Rush Net was designed by former Univ. of Miami star QB Ken Dorsey. Ken is currently an NFL Quarterback coach. The QB Pass Rush Net is a QB training sled with two distinct functions. Its first function is in enhancing QB's abilities to throw accurately with pocket pressure. The QB Pass Rush Net is on wheels. The sled has 3 targets set in an arc. The coach uses the push bar at the center of the sled to push the sled at the QB. The moving sled simulates rushing defenders. The caster wheel at the center of the sled allows the sled to move at any angle. The coach can simulate pressure coming from the middle, left, or right. Work from the shotgun or work from under center. The QB and coach can work on any drop steps and route patterns, and then create the pressure and timing necessary to succeed at those routes. The 3 large targets disrupt the QB's vision and throwing lanes. The targets are 7' tall x 3' wide and thus simulate rushing defenders. The QB must throw over, between, or around the targets. The second function of the QB Pass Rush Net is as a throwing net. Each target has a distinctive pocket sewn into the vinyl. Each pocket is sewn at a different height. Multiple QBs can throw at the pockets while the sled is stationary, or even perhaps as it is being moved. Each of the 3 targets are on different angles so the QB also gets a feel for the receiver at an angle. Each target net is sewn with heavy red webbing to take the abuse of high velocity throws (or nice touch throws, it's whatever you want to work on). One sled with two roles. Why not make the QB Pass Rush Net part of your training progression and help your QBs succeed? It's affordable, it's durable, it's versatile. The 3 wheels are no-flat foam filled wheels. Total sled width is 17'. The sled is painted matte black. Warranty 2 years. Ships motor freight.

Model: QBPR Price: \$1999

PRO PORTABLE QB NET

The Pro Portable QB Net has several benefits to increase quarterbacks' throwing mechanics, arm strength, drops, and accuracy. Make Plays! The large Portable QB Net allows coaches to focus on teaching technique versus chasing footballs. Use this tool so that your quarterbacks don't miss throws. The Portable QB Net has 3 sewn in targets and 1 round target. Improve your Quarterback's high-release. It's also useful for arm-conditioning. It is suitable for large or small groups. Adjustable tilt net allows working on fade-routes at varying distances. The Portable QB Net can be adjusted quickly with a simple pin adjustment. The Pro QB Net can be attached to a Gator to simulate passing to a receiver. Weather resistant netting. 4 foam filled wheels, 2 of which are caster wheels. Powder coated black.

Pro Portable QB Net
Model: QB1
Price: \$1395

Optional Tow Handle
Model: QB2
Price: \$115

254 lb
Sled Weight

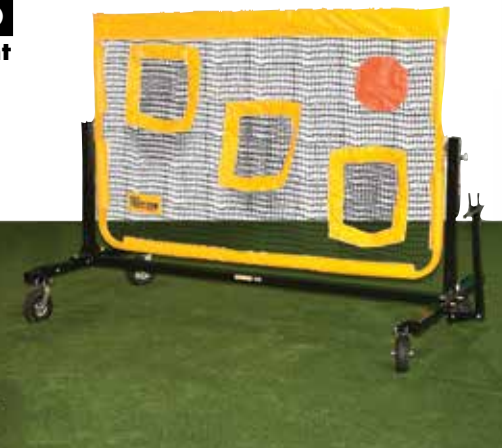

PRO HANGING QB NET (shown on right)

The Pro Hanging QB Net has more features than any other net of its kind. Use the Net so that your QBs don't miss throws; so they don't miss open receivers. Use this net to work on throwing mechanics and vision. Each net has three sewn-in pockets to capture the football. All three of these pockets are sewn at different heights, simulating different routes and catches. All of the pockets have heavy yellow borders sewn into the netting. Also included with the net are five adjustable targets which are all different colors and can be placed anywhere on the net. The netting is coated to protect it from the sun and rain. To keep the net in place we sew chain into the bottom hem. This gives the net weight and keeps footballs from skidding away from the net and helps during windy conditions. Size is 18'6" wide x 12' high x 60 lbs. See special deals below when purchasing with other QB items. Warranty 2 years.

Model: QBN1

Pro Hanging QB Net

Price: \$550

Model: QBN1-T

Purchase with a QB Tee and save 10%

Price: \$495

Model: QBN1-C

Purchase with a Center Machine and save 15%

Price: \$467

FAX: 803-366-3633

Call Toll-Free: 800-841-5050

PORTABLE QB NET

A truly portable Short Pass accuracy net. Sets up quickly, no screws, no snaps, no snags, no tools required! Rigid steel and fiberglass pole construction. UV protection for added durability. Includes carry bag for easy transport. Weighs only 29 lbs. Warranty 6 months.

Model: QB5

Portable QB Net

Price: \$399



QB-TEE

Timing is everything! Allows the coach to measure timing, speed and quickness. When the player removes the ball from the cradle, the built-in timing clock is triggered. When the programmed time interval expires (i.e 3.4 seconds) the buzzer will sound. If the buzzer goes off before the player releases the ball, the play is dead. Features a built-in audible timing device, programmable timer, and two-position ball cradle.

Model: QBT **Price:** \$149

Replacement Timer for QB-TEE

Model: QBTR **Price:** \$49



CENTER MACHINE

To snap the football the QB bumps the butt pad. The butt pad offers resistance. The QB rides the butt pad, causing the ball to snap. When the ball snaps, the QB grabs the football and takes control of it. The football snaps quickly. To reset the machine, the QB places the ball back into the ball holder and pushes the arm back, locking it in place for the next snap. This takes about 2-3 seconds. With the Center Machine you can practice timing routes that will defeat defenses. Allows your centers to continue working on their specific skills and allows your 2nd and 3rd string QBs to gain repetitions. Designed for right-handed or left-handed QBs. Built tough and durable. Professionally engineered. Powder-Coated Yellow. Weighs 75 lbs. 3 year warranty.

Model: CTR **Price:** \$745

QB BUMP STICK

Use the foam-padded QB Bump Stick to simulate pocket pressure. Increase your QB's ability to put the ball on-target under pressure. The Bump Stick gives the coach extra reach and target specificity. Can also be used for RB ball-security.

Model: QBBS **Price:** \$115

Order 2 or more and save 10% (\$103)



QB PLAYHOLDERS ADULT SIZE SINGLE PLAY CARD HOLDER.

Soft wrist band of stretch terry cloth with clear envelope to hold included playcard. Black only. Window is 4 3/4" x 2 3/4".

Model: APH1 **Price:** \$5

ADULT SIZE TRIPLE PLAY CARD HOLDER.

Velcro close front. Holds 3 times the information. 6 Colors: Black, White, Scarlet, Gold, Royal, & Navy

Model: APH3 **Price:** \$7

YOUTH SIZE SINGLE PLAY CARD HOLDER. 5" LENGTH. BLACK ONLY.

Model: APHY **Price:** \$5



SOLO KICKER PRO



SOLO KICKER PRO (shown above)

Twice as big as the Solo Kicker at 11'6" tall x 8' wide. The largest net of its kind and the only net designed specifically for Kickoff practice. Built with the height and strength necessary for kickers that need a running start to drive the ball higher and harder and designed to allow the kicker to continue running past the kick. Reliability, portability and strength make the SoloKicker the resonated training net among Division One University Football Teams such as USC, UCLA, Notre Dame. Sets up in 180 seconds without the use of tools. Easy portability and storage. One year limited manufacturer warranty. Weight 42 lbs., Roller Case Size - 48" x 10" x 8".

Model: BOW-PRO **Price:** \$599



FAX: 803-366-3633

SOLO KICKER (shown below)

Quick and easy setup and take down, thus very easily portable for games and practices. Includes small 50" x 12" Carry Case for easy travel. All-black kicking net and frame. Optional Orange Snapping Target (3 open pockets). Lightweight yet stable design 23 lbs. 87" H x 46" W. Bottom catch net keeps balls off the turf.

Model: WZ-BN1 Solo Kicker **Price:** \$399

Model: WZ-BNT Snapping Targets **Price:** \$49

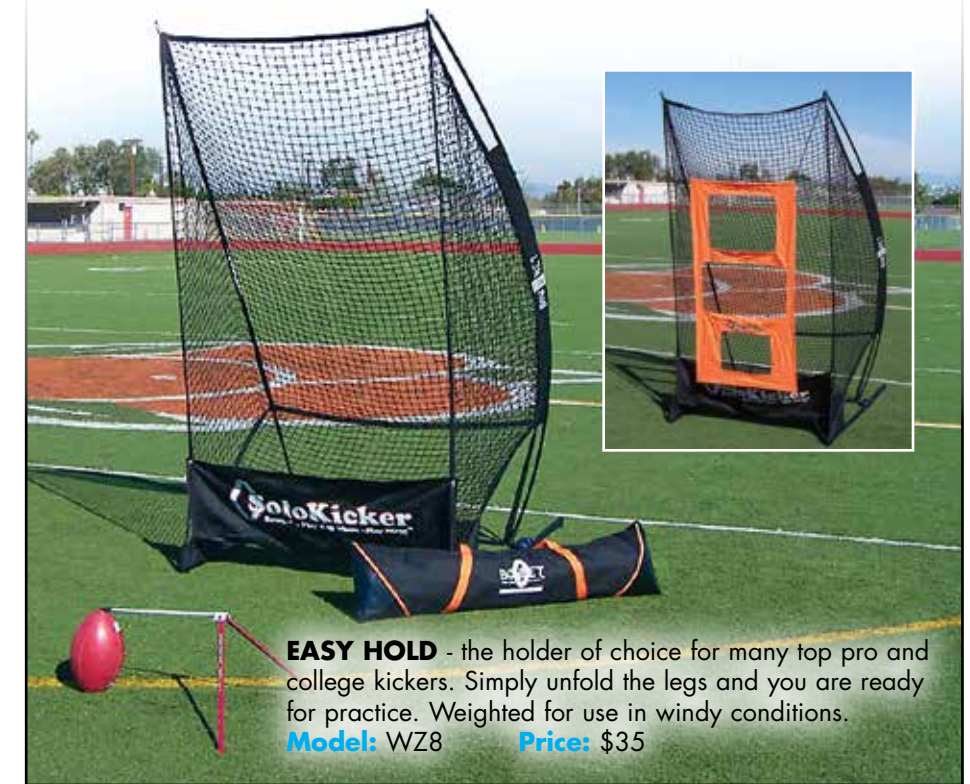

EASY HOLD - the holder of choice for many top pro and college kickers. Simply unfold the legs and you are ready for practice. Weighted for use in windy conditions.

Model: WZ8 **Price:** \$35

FADE NET

Perfect your quarterback's fade route with Bownet's 8' Portable Quarterback Fade, Pass, and Snap Practice Net. Reliability, portability and strength make the QB Fade Net the resonated training net among coaches and quarterbacks. With a height of 8' and a 45 degree adjustable basket, Bownet's QB Fade Net is able to catch every pass from every angle. Bownet's E.A.S.® technology (Energy Absorption System®) helps reduce stress and tension on the netting, extend its lifespan, create a more balanced net, and add flexibility and stability upon impact. The original BOW-poles and rigid steel frame are engineered to distribute weight across the bottom base to prevent tipping during all weather conditions. Leave more time to play with a net that sets up in 60 seconds without the use of tools or guide wires. The net has rubber non-marking feet to prevent damage to floors and provide stability and traction indoors and outdoors. When practice is over, collapse the net and place in the provided manageable bag for easy portability and storage. One year limited manufacturer warranty.

Model: QBF **Price:** \$299

Call Toll-Free: 800-841-5050

JUGS THROWING MACHINES



JUGS FOOTBALL MACHINE (shown above)

Catch more footballs. Work with LBs and DBs on their pass interception skills. Practice kick, punt and passes from 5 - 80 yards. Adjustable, will throw spiral or end-over-end tosses. Requires 110-volts.

Model: M1700 Jugs Football Machine **Price:** \$2595

FIELD GENERAL MACHINE

The Field General Machine is a slightly scaled down version of the regular machine. Throws accurately up to 50 yards. Punts with a hang time over 5 seconds. Lightweight and portable. Weighs less than 95 pounds. Comes with its own transport wheel. Requires 110-volts.

Model: FG1000 Jugs Field General Machine **Price:** \$2099

SNAP ATTACK FOOTBALL MACHINE

Designed by football coaches, the Snap Attack football training machine is a snap, pass and kick machine that will maximize your time on the most difficult to practice phases of the game. The Snap Attack Football Machine's solid polyurethane throwing wheels firmly grip the ball for an accurate spin. The wheel guards protect arms from potential wheel burns as well as help to keep the wheels as dry as possible in inclement weather. Rapid fire and multiple ball drills are part of the Snap Attack's repertoire. The two independently running electric motors create not only a near instantaneous recovery time, but furnish enough power to put the football anywhere on the field. On the passing stand, the Snap Attack can pivot instantly in any direction, accurately throwing passes, punts and kickoffs to any location on the field. In the lowered position at ground level and realistic angles, machine snaps ball to any depth in shotgun and pistol formations, extra points and punts. No second cradle is required for kickoff. Quality Realistic Reps Without the Center!

Model: 130-1100 Snap Attack Football Machine **Price:** \$3999

Model: 130-3004 Adaptor for Crowther Machine Cart **Price:** \$199

MACHINE CART (Throwing Machine sold separately)

The Crowther Machine Cart provides easy mobility of your Throwing Machine, generator (or extension cords), and footballs. The tow handle allows you to pull the cart, or attach the cart to a field vehicle. The metal basket holds multiple footballs or a generator (a larger generator also fits on the deck of the cart). The cart has four foam-filled wheels with casters for easy transport on grass. Comes standard with 1½" ball hitch.

Model: JG1 Machine Cart **Price:** \$1095

Order any Throwing Machine on this page and save 10% on the Machine Cart (\$985)



ARC RUNNER

The Arc Runner is made from tough PVC tubing. It has an approximate 12' diameter, and will keep its shape when set up. Improve explosion, footwork, and body angles of your players.

Model: ARC1 **Price:** \$65

Order 2 and save 10% (\$58)



GUNSLINGER HARNESS:

The Gunslinger is a harness that attaches to virtually any football harness or sled (not just a Crowther sled) or pop up dummy. It's a two-part pad. A football is held securely in a webbing, called the "Sling," and a small belt attaches to the sled pad, called the "Holster." Setup is quick. The player tries to dislodge the ball from the holster. The degree of difficulty in knocking the ball loose from the holster is adjustable.

Model: GNSL **Price:** \$49



SNAPPER STICK

The Snapper Stick is a foam football attached to a wooden stick. This is the original and official Snapper designed by Wayne Nunnely (NFL D line coach) and Chris Smith (NFL equipment manager). Used to simulate the snapping of the ball, it can improve takeoff and explosion of DLs. The ball is made from a dense foam type of material with the stick molded into the ball. The Snapper allows the coach to view the entire drill while standing. Used by special teams coaches to practice keying on the ball during punt drills and PAT/FG block drills. Used by wide receiver coaches to practice keying on the ball.

Model: SNA1 **Price:** \$59

Order 2 and save 10% (\$53)



FUMBLE PRO

The FUMBLE PRO is a training tool designed to improve ball security by teaching players to hold the ball in the most secure manner possible to reduce or eliminate fumbles. By using the FUMBLE PRO in drills, you can simulate the same forces a player will experience in games in a way no other training tool can achieve. The Slap Handle creates a large impact force with just a simple flick of the wrist that is then transmitted to the ball. This allows the coach to generate MAXIMUM force on the ball without having to punch or hit the ball, or follow the player through the drill. You never miss when trying to knock the ball out of the player's hand, or hit the player instead of the ball! No other product on the market can generate the game-like impacts on the ball like the FUMBLE PRO! Reinforced carry bag included.

Model: FBO Fumble Pro **Price:** \$129



FUMBLER STRAP

The Fumbler Strap is designed to enhance ball awareness and security. It holds a football on one end, secured in an elastic webbing, and has a coach's handle on the other end.

Model: PST1 **Price:** \$49



ADJUSTABLE ALL-IN-ONE LINE-UP TRAINER™

The Adjustable "All-in-One" line-up trainer (pictured below) simplifies the placement of defensive front personnel. The "Even" numbers are head up when lining up on the Center, Guard, and Tackle. The "Odd" numbers determine shading to the outside shoulder. The "Even" numbers with the letter "i" represent shading on the inside shoulder. This lineup trainer helps teach a universal system of defensive alignment. A great teaching tool for sub-varsity teams. A time saver for aligning scout teams. Allows for multiple defensive fronts. Teaches gap control. Improves linebacker alignments. Coaches can call out defensive fronts by number. Each position is marked on a slider and can be moved to suit your individual splits. Each end is sand weighted. Color: Blue/Yellow.

Model: LUTA **Price:** \$199

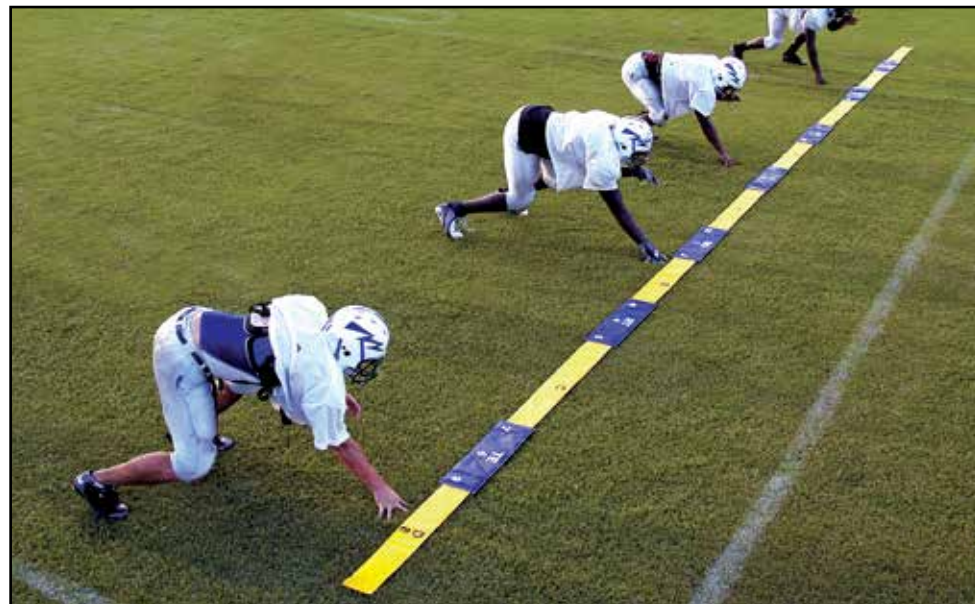

REGULAR LINE-UP TRAINER

The Crowther Regular Line-Up Trainer is 35' long. One side of the trainer is marked for offensive positions, and the opposite side is marked for defensive positions. Each position is marked on a slider and can be moved to suit your individual splits. Each end is sand weighted. Colors: Red/White/Blue/Yellow.

Model: LUTR **Price:** \$149



CROWTHER SPACER PADS

The Spacer Pad(s) represent players. The Spacer Pads allow the coach to set up a front or formation without using players. Spacer Pads stand upright without assistance. The Pad measures 38½" tall x 23" dia. x 20 lbs., so it represents the width and depth of a player. Use the Pads to simulate an offensive line for stunt and front periods. Drills can be run faster and with more focus on the execution of the play. The coach simply changes the formation/position of the Spacer Pad and the defense or offense makes their adjustments and runs through assignments. No crushed trash cans to deal with (from players sitting on them). Spacer Pads are appropriate for contact. Can also be used for agility markers, targets for QBs, or used for OLs to cut block without having someone hold a bag. Pad includes 2 handles on back. Helmet and numbers screened on each pad. Purchase in any quantity, we recommend 5 or 11 pads. Black only.

Model: SPAC **Price:** \$109 Order 5 or more and save 10% (\$99)

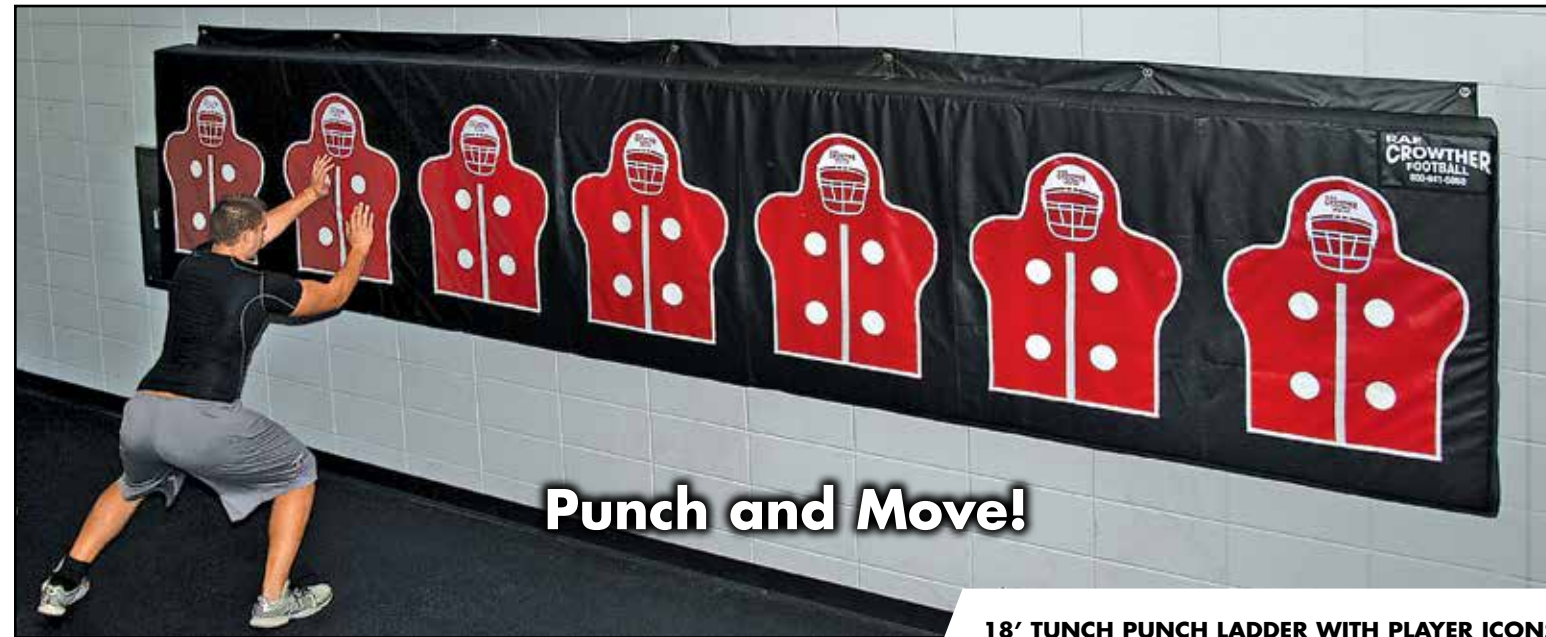

Punch and Move!

18' TUNCH PUNCH LADDER WITH PLAYER ICONS

PUNCH LIKE THE PROS:

The Tunch Punch Ladder was designed by two NFL veterans, Tom Myslinski and Tunch Ilkin. The Tunch Punch Ladder (TPL) is essentially a speed agility foot ladder mounted on a wall. Let's have Tom Myslinski explain, "Through working with and training under Tunch Ilkin, developer of 'Tunches Punches,' I have developed the Tunch Punch Ladder. Together, we are finding it extremely useful and beneficial in training our athletes. We, as football coaches, understand the importance of the feet in our sport. More importantly, we also understand the specific role the hands play in striking, blocking, and attacking. The more we use this teaching tool, the greater our results have been in strengthening and reconditioning our athletes on the correct motor programs."

HOW YOU CAN BENEFIT:

Protect your QBs and get to their QBs. The Tunch Punch ladder allows your players to gain thousands of repetitions they would not have been able to accomplish on the field. Your practice time is short; your individual time is shorter. As you know, the art of striking with the hands is difficult to learn. Why not place a Tunch Punch ladder in the weight room or hallway and punch year round? OLs can learn the hand combat necessary to take on fast DLs. DLs can learn the hand skills required to defeat strong OLs and make plays. It's a tool to learn their craft. A player can practice alone or in a group, with or without a coach.



9' Tunch Punch Ladder with Player Icons

Model: 9TPLI 9' Tunch Punch Ladder with Player Icons **Size:** 9' x 42" Height x 8" Thick x 4 Grommets. **Price:** \$895

Model: 18TPLI 18' Tunch Punch Ladder with Player Icons **Size:** 18' x 42" Height x 8" Thick x 7 Grommets **Price:** \$1595

Background Color	Black	Navy	Royal	Purple	Maroon	Red	Orange	Yellow	Green	Player Icon Color	Black	Royal	Red	Orange	Yellow
------------------	-------	------	-------	--------	--------	-----	--------	--------	-------	-------------------	-------	-------	-----	--------	--------

FAX: 803-366-3633

Call Toll-Free: 800-841-5050

TUNCH PUNCH LADDERS™
(US Patent #D510,399)



All-Pro Tackle, Tunch Ilkin

TUNCH PUNCH DVD!

This 60-minute DVD covers a great amount of information concerning line play. Demonstrated by Coach Ilkin and Coach Myslinski. Tunch Ilkin is a former All Pro Tackle who commands an extensive knowledge of the game and is considered one of the premier teachers of collegiate and pro teams.



Model: TPL DVD
Price: \$29



FOLDABLE LANDING MAT / CRASH MAT

Block two punts on one play... The Foldable Landing Mat provides a safer landing area for your athletes by protecting their heads from ground contact and reducing the wear on their skeletal systems. Work extension drills, form tackling drills, and punt block drills. Folds in half. Four handles on sides for carrying. Weighs 145 lbs. Size: 10' L x 6' W x 12" H. Color: Yellow Only.

Model: LAN1 **Price:** \$795

Order 2 and save 10% (\$715)

HALF ROUND STEP-OVERS

8" tall half round shape. Teach players to work their feet quickly and maintain a good football position with heads up. Shuffle over bags, mirror drills. Teach movement and direction change. Use as drill markers and lanes. Use as standup dummy as well. Two handles on back. Weighs 7 lbs. Size: 48" L x 18" W x 8" tall. Colors: Black, Royal, Red.

Model: HR8 **Price:** \$115

Order 2 or more and save 10% (\$103)

Order 5 or more and save 15% (\$98)



TRAPEZOID STEP-OVERS

Rae Crowther 8" Trapezoid Dummy in Black

Includes: 8" tall, 48" long, 16" wide, 18 oz. vinyl coated nylon. Handles: 1 handle on end. Weight: 9 lbs. Warranty: 2 year factory warranty. Pad Color: Black.

Model: TR8 **Price:** \$129

Order 2 or more and save 10% (\$116)

Order 5 or more and save 15% (110)

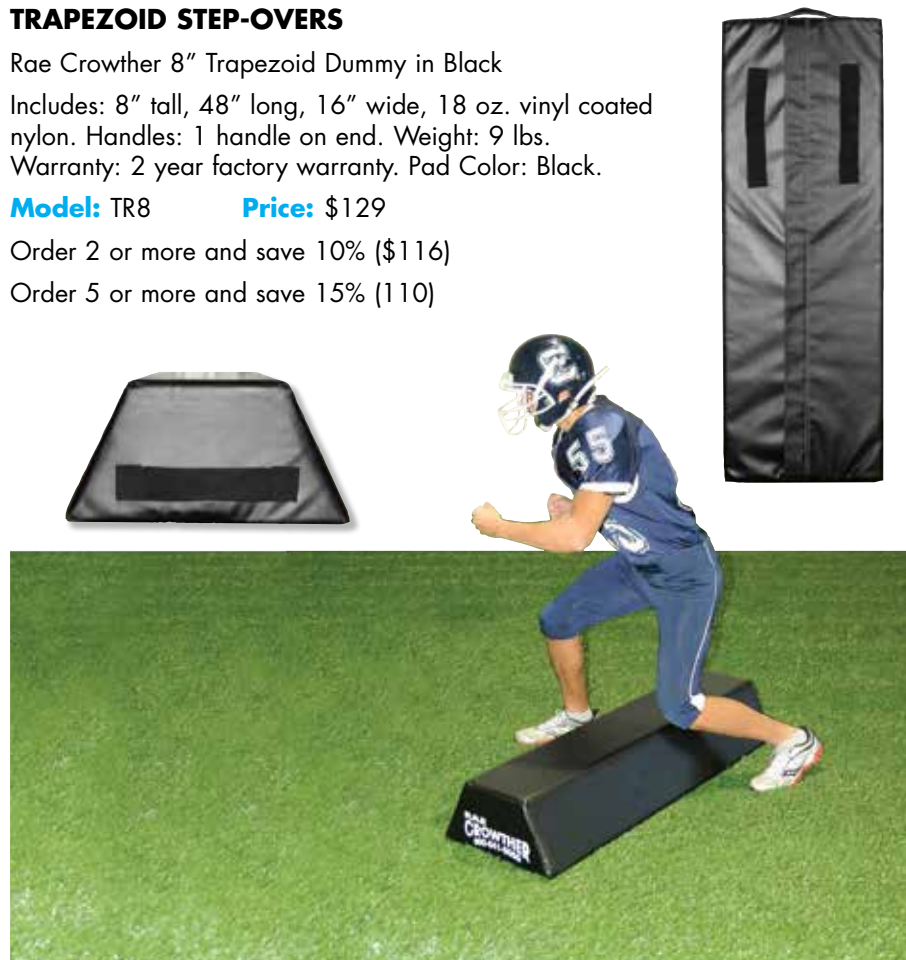

POP UP DUMMY

Our 60" Tall Pop Up Dummies free players and coaches from holding bags upright. Our removable and replaceable bases extend the life of the dummy. No zippers to align or worry about. No sand, no leaks, and nothing to inflate. These are premium pop-ups. Warranty 1 year. Weight: 88 lbs. Pad colors: Black, Royal, Red.

Model: POP7 **60" Pop Up** **Price:** \$499

Order 2 or more and save 10% (\$449)



Replaceable bases increase the life of your Pop-Ups

PASSING ARMS

Passing arms provide a QB-like target for the rusher. One arm is down and one arm is up in a throwing position. Each arm has Velcro sewn into the padding. Attach a Gunslinger pad to the arms. Arms attach in the back with a buckle strap. Color: Black

Model: POPP **Price:** \$109



LINEMEN ARMS

Provide DLs with a pass rush target. Chop and rip the arms. Each arm has Velcro sewn into the padding. Attach a Gunslinger pad to the arms. Arms attach in the back with a buckle strap. Color: Black

Model: POPL **Price:** \$99



V ARMS

The V Arms have a more realistic "look" than traditional pop-up arms. The V Arms offer more resistance to the players. They make an exceptional target for chop, rip, and swim techniques. Velcro is sewn into the cover for attaching a football. Color: Black

Model: POPV **Price:** \$109



COREFIRE FUNCTIONAL TRAINING BAGS™



17" Dia. X 47" 14" Dia. x 47" 11" Dia. x 36"

- Model:** CF25 25 lb **Price:** \$149 (Order 3 or more and save 15%) \$121
- Model:** CF50 50 lb **Price:** \$215 (Order 3 or more and save 15%) \$183
- Model:** CF75 75 lb **Price:** \$285 (Order 3 or more and save 15%) \$242

CoreFire bags create dynamic training movements that foster hip explosion, core strength, body balance, multi joint movements, and real life grip awareness. A fantastic functional tool if you want to get the ankles, knees, and hips working. No sand or rubber infill is used inside the bag. The bag contents are a special blend of heavy rebound foam. The bag weight is spread evenly throughout, with no heavier or lighter end.



HERCULES PUNCH BAG

Crowther Hercules Punch & Conditioning Bags are multi-purpose bags with heavy duty construction. Use for punching, rotational exercise, front, back, and overhead squatting, throws and core exercises. Allow range of motion and movement while stressing the weakest link – grip. We do not sew handles into the bags because that destroys the open handed nature of the punch bag. All bags come in black with a large screen print of the weight on the bag. If you want the best and most hassle free bag, you have it here! Two year warranty.



- Model:** HPC15 15 lb **Price:** \$42 (Order 3 or more and save 15%) \$36
- Model:** HPC25 25 lb **Price:** \$62 (Order 3 or more and save 15%) \$53
- Model:** HPC50 50 lb **Price:** \$99 (Order 3 or more and save 15%) \$84

SHELL STICK

Use the Shell Stick as a way for players to learn how to properly utilize a stiff arm when running to the perimeter. Proper placement on the face-mask not only gives a realistic feel but it also teaches players how to avoid penalties when stiff-arming. On defense use the Shell stick to defend against cut-blocks. Placing one hand on the helmet and one hand on the shoulder pads give players a game-time feel on how to attack and defend against a player trying to lunge at their feet. Use the Shell Stick to teach running backs how to take on contact with their shoulder and not their head. Younger players tend to dip their head when they're about to take on contact. Use the Shell Stick's shoulder pads as a way to provide "soft contact" to players as they are running to see how they react to contact. Warrant 2 years.

Model: SHELL-BK **Price:** \$299

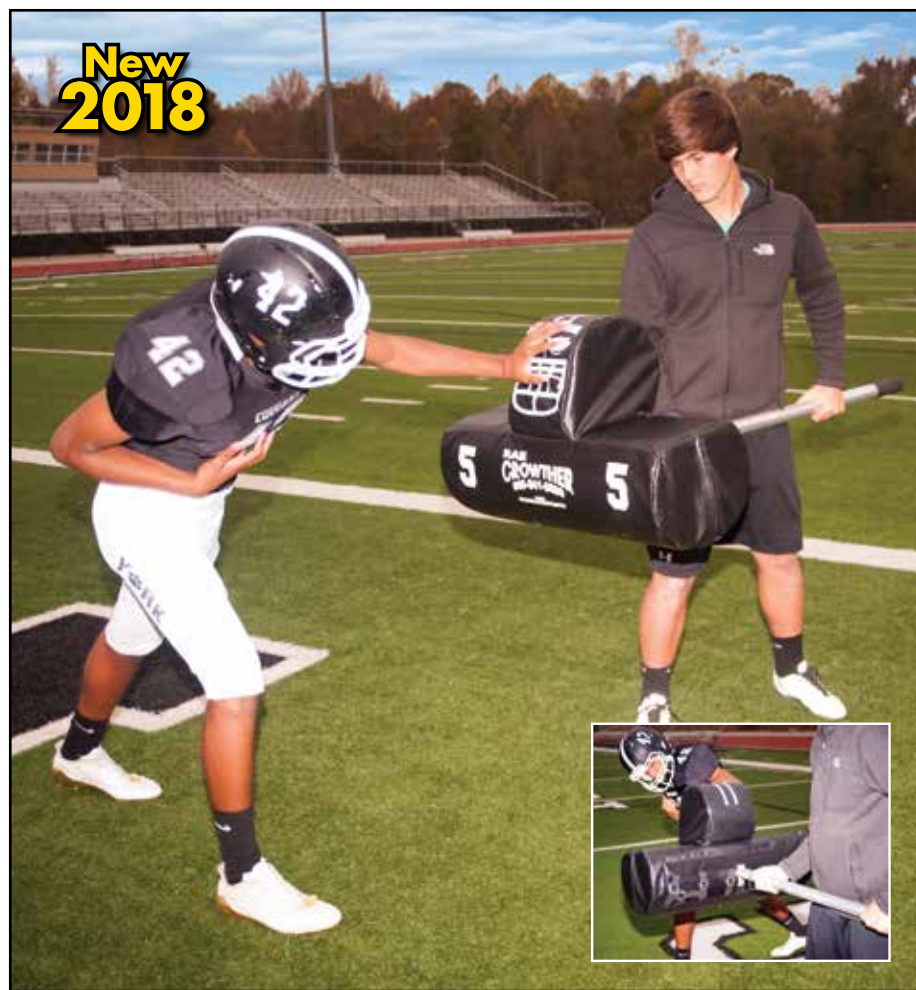

New 2018

70 LB. HEAVY ROUND

70 lb. Heavy Round Dummy. 16" dia. X 48" tall, 18 oz. vinyl coated nylon, 2 handles on back, 2 on bottom, warranty 2 year. Pad colors: Black.

Model: 70HRD **Price:** \$219

Order 2 or more and save 10% (\$197)

Order 4 or more and save 15% (\$186)



40 LB. SQUARE DUMMY

Rae Crowther 40 lb. Square Dummy. 48" x 14", X 18 oz. vinyl coated nylon. Handles: 2 handles. Warranty: 1 year factory warranty. Pad colors: Black.

Model: SQD **Price:** \$195

Order 2 or more and save 10% (\$175)

Order 4 or more and save 15% (\$166)



PUSHBACK SHIELD

The Pushback Shield provides a curved hitting area. Use for quick mobility drills; hold the shield away from the body or against the chest for punching. 24" L x 17" W x 4" Thick. Weighs 4 lbs. Pad colors: Black, Royal, Red.

Model: PSH **Price:** \$59

Order 2 or more and save 10% (\$53)

Order 5 or more and save 15% (\$50)



CURVED BIG SHIELD

The Curved Big Shield is like the Pushback Shield but larger, wider, and thicker. It has a curved hitting area and provides more protection of the lower body for heavier contact drills. 36" L x 22" W x 5" Thick. Weighs 6 lbs. Pad colors: Black.

Model: CBS **Price:** \$108

Order 2 or more and save 10% (\$97)

Order 5 or more and save 15% (\$92)



HEAVY 17 LB. DUAL-ARM SHIELD

The Dual Arm Shield is the most advanced shield on the market. The Dual Arm Shield challenges the player to make proper hand contact. 17 lb. weight keeps the shield low during drills. Multiple handles. The arms on the shield block the player's hands that are too wide or too high, thus teaching the player game-like punching skills. Pad colors: Black.

Model: DAX **Price:** \$169

Order 2 or more and save 10% (\$152)

Order 4 or more and save 15% (\$144)



CHEST PAD

The Chest Pad frees the scout team player from holding a pad. The Chest Pad is worn around the neck and back with adjustable straps. The player has full movement of arms and hands. 22" L x 13 1/2" W x 3" Thick. Pad colors: Black.

Model: CHP **Price:** \$119

Order 2 or more and save 10% (\$107)

Order 4 or more and save 15% (\$101)



FOREARM SHIELD

Forearm Shields provide more range of motion than traditional hand-held shields. Especially useful for linebackers, giving them the ability to move while hitting with a padded surface. Normally used for "shell" days. Curved hitting surface. Each pad comes with a hand and forearm strap. Sold in pairs. Pad colors: Black. 25" L x 10" W x 3" Thick. Weighs 2 lbs.

Model: FRS **Price:** \$85

Order 2 or more and save 10% (\$76)

Order 4 or more and save 15% (\$72)

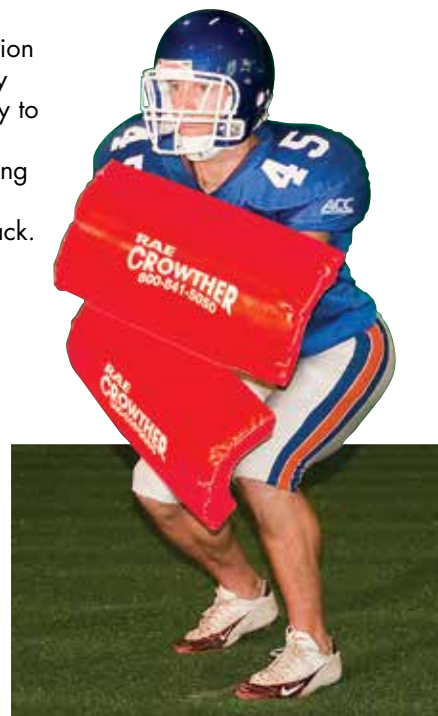

BULLET ARM

Cylinder shaped pad allows the coach to slide his hand and forearm inside the pad and grip a handle in the inside. The pad protects the coach from live contact during escape moves. Players can chop, rip, and swim and the coach stays protected. The pad allows more teaching with less chance of injury to both player and coach. 22" L x 9" Diameter. Order four or more and save 10% (\$94). Pad colors: Black.

Model: BULL **Price:** \$105

Order 2 or more and save 10% (\$94)

Order 4 or more and save 15% (\$89)



Order 24/7 at www.raecrowther.com

REPLACEMENT PADS

REGULAR S-PAD COVER

Model: ADV100 **Price:** \$159



With New Heavy Foam: 35 lbs. per pad

DUAL-ARM S-PAD COVER

Model: ADV105 **Price:** \$205



S INTERIOR PAD SET

Model: ADV108 **Price:** \$329



Z LEVERAGE PAD

Model: ZL-PAD **Price:** \$295



Fits Classic, Shockwave, and Z Leverage Sleds. Feel the quality of our pads and their heavy construction: 22 pounds per pad

6" FLAT SPRING PAD - BLACK

Model: RP100 **Price:** \$259



WORLD BOD OR TACKLING PAD - BLACK

Model: RP105 **Price:** \$259 or **Model:** RP106 **Price:** \$279



CLASSIC T-PAD - BLACK

Model: C125 **Price:** \$229



ENDURO PAD

Model: C100 **Price:** \$199



With New Heavy Foam: 16 lbs. per pad





SPECIAL TEAMS MAT

Avoid costly timeouts; ensure the right players are on the field. Standard size: 12' x 6'. Standard colors: black with white dots. Call for custom school colors. Custom letters available in 1 or 2 tone colors.

Model: SSTM **Price:** \$379

Special Teams Lettering:

1 color: \$9 per letter
2 color: \$15 per letter

GOAL POST PADS WITH SEWN ON LETTERS!



GOAL POST PADS

You will not find a better looking and quality Goal Post Pad. Hand sewn letters give the pad a "stand out look" and very strong durability. The Vinyl is 18 oz. vinyl coated nylon with Velcro enclosure. Foam is encased from the goal post and elements (other types of Goal Post pads just protect the exterior of the foam). Again, letters are sewn on as opposed to screened. Size: 6' tall x 18" O.D. x 7" I.D. A large selection of colors is available. (Sold per pair.)

Model: GPP18 **Price:** \$625 a pair

Model: GPP18 - LETTERING **Price:** \$12 (Per letter - includes an outline color and a letter color)

PORTABLE GOAL POSTS

The H style portable goal post is constructed from galvanized metal. Two wheels per goal. Price per goal. Windstreamers not included. In high wind areas, we suggest adding sand bags to the base.

Model: PORH High School; 23' 4" Width **Price:** \$1295

Model: PORC Collegiate; 18' 6" Width **Price:** \$1295



WINDSTREAMERS

Model: WS201

Price: \$29 (Set of 4)

Size: 4' x 42"

FOOTBALL BAG

Holds 12 footballs in 32" L x 24" W x 12" H bag. Uniquely constructed of 18 oz. waterproof coated vinyl with interior flap and Velcro closure for quick access to footballs during light rain. Interior dividers separate dry from wet footballs. U-shaped zippered opening with heavy duty 2" webbing wrap-around straps and end carry handles. Black only.

Model: FBAG **Price:** \$99



SIDELINE TURF PROTECTORS



This is the ultimate bench tarp as used by major colleges and NFL teams. It is made with advanced industrial grade Polyester-Vinyl Matrix (PVM) fabric that keeps cleats from penetrating but allows rain to drain through. This remarkable material does not absorb or retain water, so it does not double in weight when wet like the non-woven fabrics in other bench tarps. Important: this is not a geo-textile material. Geo Textile material becomes 3X heavier when wet, absorbs blood and sports drinks, and becomes foul in storage. Edges are reinforced and double stitched with grommets installed every 18" all around. Easy to install, remove, and store. 17 standard colors available and they can all be digitally imprinted.

Model	Size	Price \$
3640	Full Size: 15' x 150'	\$1895
3641	15' x 125'	\$1745
3642	15' x 100'	\$1495
3643	Half Size: 15' x 75'	\$1295
3644	15' x 50'	\$995
3630	6" Stakes - Pkg. of 30	\$29
3632	6" Stakes - Pkg. of 115	\$69

Model	Size	Price \$
3654	15' x 150'	\$1595
3653	15' x 125'	\$1395
3652	15' x 100'	\$1195
3651	15' x 75'	\$1095

The Sideline Track Protector is the smart way to cover your expensive track while resisting and cushioning against cleats and the constant pounding of cheerleaders. Made with the toughest polypropylene geo-textile fabric and double stitched vinyl edging (with steel chain sewn inside the edging), the Bench Zone™ Sideline TRACK Protector stays down in high winds **WITHOUT STAKES OR STAPLES.**

To reduce the handling weight and make it easier to install, the longer protectors come in two sections that are easily joined with Velcro® hook & loop strips that are double-stitched along the entire length of each section's overlapping, chain-free center edges.

Color is black with choice of white or gold edging.



CROSS OVER ZONE PROTECTORS



Save your modern track surface from damaging football cleats and other walk over traffic. This easy-to-install, temporary cover resists and cushions against football cleats, yet allows rain to drain through.

Made with a tough, durable polypropylene non-woven fabric. Its entire edge is vinyl-wrapped, and the galvanized steel chain is inserted all around to keep this cover down in winds **WITHOUT STAKES OR STAPLES** that can damage the track.

Color is black with choice of white or gold edging. Kept in stock for quick shipping.

Model	Size	Price \$
3663	15' x 30'	\$695
3664	15' x 40'	\$799
3665	15' x 50'	\$935
3667	7.5' x 30'	\$495
3668	7.5' x 40'	\$595
3669	7.5' x 50'	\$695

4



PADDED FLIP DOWN
Model: PDB-O
Price: \$129



VARSITY 7' CHAIN
Model: SCS-O
Price: \$179



COLLEGIATE 7'-5" CHAIN
Model: CCSO
Price: \$199



FOLDABLE MARKERS
Model: 1241WX-O
Price: \$149

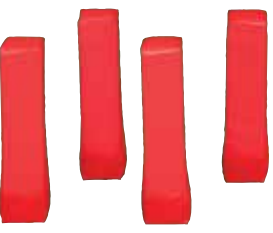

PYLON SET (4)
Model: 251WEP
Price: \$49



Red Model: SCP2-R
Price: \$14



Blue Model: SCP2-B
Price: \$14



Gold Model: SCP2-Y
Price: \$14

SCRIMMAGE CAPS
Fits modern, large helmets. Material is knit fabric.



Red Model: SV-R
Price: \$5



Blue Model: SV-B
Price: \$5



Gold Model: SV-Y
Price: \$5

SCRIMMAGE VESTS
Material is polyester, no binding, elastic bottom, one size fits most.



12" RUBBER CONE
Model: C12
Price: \$8



9" PLASTIC CONE
Model: P9
Price: \$2



6" RUBBER CONE
Model: C6
Price: \$3.50



7" DIA. DISK CONE
Model: CD7
Price: \$1



9" SPOT MARKER
Model: SM12
Price: \$32 (Set of 12)

FOOTBALL HELMET CART

Ensure players can easily find their helmets at the start of the game or after halftime thanks to the five shelves that fit up to 50 football helmets with facemasks. Roll the helmets right out to the team on the cart's four heavy-duty swivel casters, two of which have locks for holding the cart in place when needed. Color: Black. Product Height: 64 in. x Length: 61 in. x Width: 24 in. x Weight: 61 lb.

Model: HRAK Price: \$289

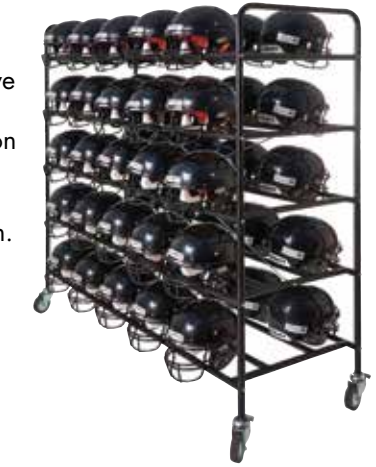

COMBO SHOULDER & HELMET RACK

This rack holds up to 30 shoulder pads and 32 helmets to provide neat and tidy storage for the team's equipment. As players place their shoulder pads and helmets on the rack, you can rest assured that the stable, rigid base will prevent equipment from tipping over. Take the rack from the equipment room to the locker room on the four heavy-duty swivel casters. Color: Black

Model: 1378672 Price: \$349



FOUR STACK SHOULDER PACK RACK

This one rack can be used to accommodate shoulder pads for the entire football team, thanks to the four stacks that can hold between 60 and 80 shoulder pads altogether, keeping things organized and making sure that they retain their shape for a comfortable fit. Moving the pads is no hassle, as the rack's four heavy-duty casters roll around the locker room or equipment area with ease. Tubular steel construction delivers strong support for the whole team's shoulder pads. Rigid reinforced steel base adds stability to the rack to help prevent it from tipping over. Color: Black. Product Height: 68 in. X Length: 60 in. X Width: 24 in. X Weight: 52 lb.

Model: SRAK Price: \$299



WILLIE SIDELINE TV CART



Make your sideline communication more efficient with a Willie TV Cart. Willie Carts are usually used with instant replay systems such as ECHO and HUDL. The Willie Cart allows coaches and players to view two angles from their replay system simultaneously. For instance "skill" players can view the wide angle on one TV while the linemen can view the end zone angle on the other TV. Use the Willie Cart at practice or games. The cart has two independent swivel brackets that can hold two 40" high def TVs. Each TV can pivot 360 degrees so that the coach and players have multiple viewing angles. Standard features include the following items: Black vinyl cover with hold down snaps so the cover stays in place in high winds or traveling, a multi plug for charging other equipment, convenient storage box for holding controller's and cables, 4 tires, and two 40" high-def TVs. Dimensions: 48" long x 24" wide 40" high. Standard color is black. For custom cart colors please call for availability.

Model: WC1 Price: \$1899 (Includes 2 TVs)

WALL MOUNTED RACK

Black powder coated 1" steel tubing construction. Easy to install with 4 screws (not included). Will hold up to 18 balls or helmets on 3 levels. Size: 60" W x 40" H x 15" D - 18 lbs.

Model: 1197739 Price: \$139

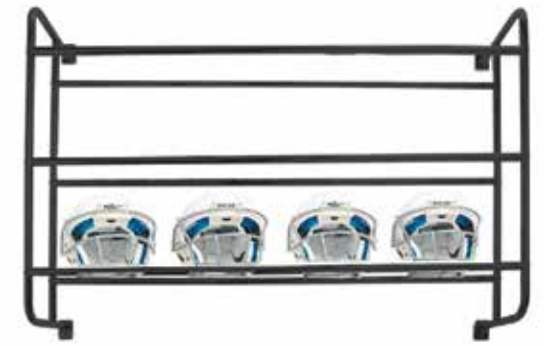

LX7520 PRACTICE SEGMENT TIMER:

The LX7520 Practice Timer is an extraordinarily useful and robust timer that will maximize every second of your practice. Few things are more important to the success of a football team than the time spent on field practicing. The LX7520 helps you organize every second of practice and keeps the team on time for each segment of practice. The timer measures 4' x 3' x 40 lbs. The timer is light weight, and with an all-aluminum construction is rust free. Automotive grade baked on enamel based paint is applied to all sides of the cabinet. You have your choice of 18 standard paint colors, as well as your choice of amber or red LED displays. The LED display circuit is coated for outdoor use. The horn is internally mounted and can be heard over 200 yards. To program the unit a wired remote is standard with 37-key controls and an LCD display. There are fifty programmable brightness levels (also available are a junction box and patch cable for hardwired installations). The timer is easy to program. For added flexibility, the display can double as a Play Clock during actual games. The timer has a five-year limited warranty. Toll free technical support via phone and online for the life of the product.

LX7520 Timer Operation:

You can create up to 45 Practice Schedules. Each Schedule may include up to 90 Periods. Each Period may range from 1 to 99 Minutes. You may also program an interval between periods from 0 to 9:59. The timer includes auto and manual horn options. All digits are 11 inches tall and can be seen on bright days and from a distance. Digits are formed from matrices of super-bright, long-lasting, energy-efficient LEDs (Light Emitting Diodes). Choose either amber or red LEDs. Our LED displays are protected by aluminum masks that allow the hard epoxy shells of the LEDs to be exposed for maximum viewing angles.

LX7520 Scoreboard face Colors:

18 colors available (Black, Grey, Navy Blue, Egyptian Blue, Royal Blue, Light Blue, Light Purple, Dark Purple, Maroon, Red, Cardinal Red, Orange, Yellow, Gold, Dark Green, Neutral Green, Light Green, White).

LX7520 Accent Striping:

19 colors available (Black, Grey, Navy Blue, Egyptian Blue, Royal Blue, Light Blue, Light Purple, Dark Purple, Maroon, Red, Cardinal Red, Orange, Yellow, Gold, Dark green, Neutral Green, Light Green, White, White with Striping).

Optional T Cart

For greater visibility and transportation we recommend the optional T Cart. The T cart comes with wheels to enhance mobility and storage of the unit. The T Cart comes powder coated in black only.

Model: LX7520 (Practice Segment Timer) **Price:** \$2895

Model: LX7520T (Optional T Cart) **Price:** \$395

Model: LX7520LOGO Optional Logo **Price:** \$95



Shown with Optional T-Cart

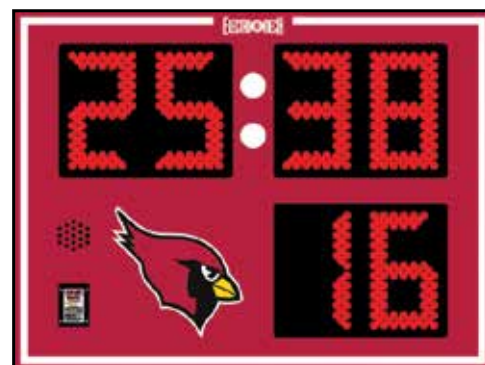

Order 24/7 at www.raecrowther.com



WATER STATION WITH INLINE FILTER (shown on right)

Connects to any clean water source. Inline garden hose water filter reduces contaminants and is good for 5,000 gallons. Powder coated frame collapses for easy storage. 8 drinking nozzles on 5 foot coiled hoses. Hoses are blue to help prevent mold / algae. Fittings and hoses are food grade. 1/2" inline valve for adjusting water pressure. Removable plug on manifold allows for several stations to connect in a series. Warranty: 1 Year.

Model: WWSTN Water Station **Price:** \$699

BIG SQUIRT (shown on left)

20 gallon tank with 8" vented cap for easy filling. 3.0 GPM 12 volt pump with rechargeable battery and waterproof charger. Aluminum frame. 6 nozzles on 5 ft coiled mold and algae-resistant hoses. Food-grade fittings, pump, and hoses. Quick disconnections for cleaning. Warranty: 1 Year.

Model: WWBQS Big Squirt **Price:** \$1195



SPORT HYDRATION CART (shown on left)

8 drinking nozzles on 5 ft coiled hoses. 35 gallon tank. 3.0 GPM 12 volt pumps with rechargeable battery and waterproof charger. Retractable handles. Retractable hitch assembly. Overhead manifold folds down for ease in storage and transport. Wide body frame helps prevent tipping. Wheelbarrow style design, on 5" x 13" pneumatic tires, makes handling easier over uneven terrain. Option: 35 Gallon Insulated Cover (Insulated cover that slides over 35 gallon water tank that adds hours to ice and cold water.) Size 30" x 60" x 44" x 150 lbs. Warranty 1 Year.

Model: WWSHC Sport Hydration Cart **Price:** \$1699

Model: W35CV Optional Insulated Cover **Price:** \$150



FIELD MANAGER (shown on left)

16 drinking nozzles on 5 ft coiled hoses. Add up to (4) more. 65 gallon tank. (2) 3.0 GPM 12 volt pumps, one for each side, with rechargeable battery and waterproof charger. 8" vented cap for easy filling. Upper deck for transporting trainer supplies and field equipment. Adjustable corner stabilizers prevent tipping when in use. Option: Use the dolly for maneuvering the Field Manager when not connected to your tractor or golf cart. Size: 15" x 41" x 7" x 29 lbs. Option: Insulated cover that slides over 65 gallon water tank that adds hours to ice and cold water. Size 60" x 84" x 65" x 400 lbs. Warranty 1 Year

Model: WWFMR Field Manager **Price:** \$3195

Model: WWDLY 2 Wheel Dolly **Price:** \$129

Model: W65CV Optional Insulated Cover **Price:** \$179



TEAM MANAGER (shown below)

This is the ultimate hydration tool when space and handling are an issue but you require a large quantity of water. Choose between two models: 8 hoses/35 gallon tank or 16 hoses/50 gallon tank. Fits thru a 33" door and has the turning ability of a play wagon. The tank is built low to the ground, which allows the manager or coach to maneuver the cart easier and importantly, allowing use of the top basket for all types of training supplies. 33" W x 60" L x 41" H.

Model: WWMG8 Team Manager **Price:** \$1595

Model: WWMG16 Team Manager **Price:** \$2495



JUNIOR S-TACKLE SLED™

US Patent #6,988,965 B2 | US Patent #6,942,585 B

The Jr. S-Advantage Tackler is a near-perfect teaching tool for youth players. The Junior S-Advantage Sleds are scaled-down versions of the regular S-Advantage Sleds. The S-Pad is the state-of-the-art design that helps teach players the proper contact position. The S-Pad shape imitates the angles of a good football player. It's a pad for all techniques. The Junior S-Advantage Sleds are designed for 65-120 pound players. The Junior S-Tackler is designed to teach the proper "take down" technique. The design of the sled allows the junior player to go full speed without contacting the metal base. Weight: 98 lbs. Pad color: Black, Red, Blue.



Model: 1SJR **Price:** \$895

KABOOM SAFETY TACKLER

The new Kaboom Safety Tackler is the first of its kind: an all-foam tackling sled. The sled is created to help prevent avoidable concussions and all other helmet-related injuries during practice. It helps teach players how to keep the crowns of their helmets out of collisions. The yellow part of the cover (sewn from shoulder tip to shoulder tip) is what we call the STRIKE PLATE. Use the Sled in practice, in a gym, in your backyard, in your garage, or inside a facility. There is no metal or wood in the sled. Use the sled with linemen from 6, 4, and 3 point stances on fit, contact, drive, and shed. 50" Tall x 67" Long x 28" Wide x 70 lbs. field weight. Warranty: 2 year limited warranty. Ships via motor freight.

Model: KAB **Price:** \$650



JUNIOR 2 - 7 S-SLEDS™

US Patent #6,988,965 B2 | US Patent #6,942,585 B

The Junior 2 - 7 S-Advantage Sleds are scaled-down versions of the regular S-Advantage Sleds. The S-Pad is the state-of-the-art design that helps teach the players the proper contact position. The S-Pad shape imitates the angles of a good football player. It's a pad for all techniques. The Junior S-Advantage Sleds are designed for 65-120 pound players. The Junior 2 - 7 S-Advantage Sleds are designed to teach the proper "fit" position. The design of the sled allows the junior player to go full speed without contacting the metal base. Modular sled design and wide pad spacing make a perfect complement for your practice drills. Get a leg up on the competition; give your team the S-Advantage.



Junior (JR) S Sleds	2 Man	3 Man	4 Man	5 Man	6 Man	7 Man
Junior (JR) Sleds (for player sizes 65 - 120 lbs.)	\$1495 Model: 2ADVJR	\$2195 Model: 3ADVJR	\$2995 Model: 4ADVJR	\$3695 Model: 5ADVJR	\$4395 Model: 6ADVJR	\$4995 Model: 7ADVJR

INDOOR CYCLING BIKE

Get ready for pedal hammering workouts. Simple adjustable ergonomic handlebars. Levers lock into place quickly. Multi-position resistance with easy control knob. Simply turn the knob to adjust. Emergency stop available by simply pressing down on the knob or handle. Fixed wheel drive system. Durable whisper quiet poly-V belt offers smooth, consistent motion. Fully enclosed drive-belt is protected from dust/debris and safer for users. Oversize and durable forged crank. Seat post can accommodate any standard bicycle seat. Seat adjustments are fore/aft and up/down. Handlebar adjustments are fore/aft and up/down. Clearly marked numeric adjustments for quick set-up. Front and side fenders protect vital components from sweat and corrosion, which equates to more workouts and less maintenance. Standard pedals are Toe Cage and Strap. Optional: oversized quick-strap pedal. 9/16ths Thread allows for after market pedals. Bike weight is 117 lb. Max user weight is 350 lb. The bike's steel frame dimensions are 41" L x 26" W x 48" H. Extra wide base for stability. Floor levelers are easy to adjust, the foot pads are under the foot tube for uneven floor surfaces. Low maintenance and easy assembly. Commercial warranty: Frame 5 years, Parts 2 years, Wear items 1 year, Labor 1 year.

Model: C510 SportsArt Indoor Cycling Bike **Price:** Call for price or go to RaeCrowther.com



SPORTSART CYCLES (UPRIGHT AND RECUMBENT)

Multi-position handrails provide a variety of grip options for all users. Low profile shroud allows easy on/off access. One-touch seat adjust allows quick and easy height adjustment. Padded oversized seat enhances comfort. Fore and aft seat adjustment for proper knee alignment while riding. Optional seat adaptor allows users to attach their own bicycle seats.

The C531u features a state-of-the-art tri-color dot matrix display with CardioAdvisor™ for accurate heart rate feedback. Multiple programs keep workouts fresh. Call for specific details on each model.

Model: C535u SportsArt Performance Cycle Upright **Price:** Call for price or go to RaeCrowther.com
Model: C545u SportsArt Institutional Cycle Upright **Price:** Call for price or go to RaeCrowther.com



SPORTSART TREADMILLS

SportsArt Treadmills deliver performance and durability. Hardworking 4.0 hp motor with FlowTec™ cooling and cleaning system. Heavy duty welded steel frame. Tri-color dot matrix display with multiple program options. MyFlex™ deck cushioning system delivers proportional cushioning effects regardless of user weight and is so durable it has a lifetime warranty. Large 22" x 62" belt provides ample running space and is constructed from carbon-weave, low friction material that is resistant to static buildup. FlowTec™ cooling and cleaning system protects drive motor and key electronics from dirt and heat buildup. Optional entertainment screen bracket. Call for specific details on each model.

Model: T615 SportsArt Precision Treadmill **Price:** Call for price or go to RaeCrowther.com
Model: T635 SportsArt Performance Treadmill **Price:** Call for price or go to RaeCrowther.com
Model: T645L SportsArt Institutional Treadmill **Price:** Call for price or go to RaeCrowther.com



SPORTSART ELLIPTICALS

Commercial ellipticals with state-of-the-art features and premium construction. Industry leading electronically adjustable stride range between 17" - 29". MyFlex™ pedal cushioning system adjusts automatically based on user weight and never loses resiliency. Breakthrough programming such as Glute Trainer, Vari-Stride™, Heart Rate Zone Trainer and Personal CardioAdvisor™. Call for specific details on each model.

Model: E835 SportsArt Precision Elliptical **Price:** Call for price or go to RaeCrowther.com
Model: E840 SportsArt Performance Elliptical **Price:** Call for price or go to RaeCrowther.com
Model: E845S SportsArt Institutional Elliptical **Price:** Call for price or go to RaeCrowther.com



SPORT TRAINING WEIGHT ROOMS

Sport Training Weight Rooms Are the Answer!

The answer to creating the most highly functional space for developing your athletes' strength, speed, and agility are Rae Crowther Sport Training Weight Rooms. Our Sport Training Rooms provide the best strength, movement, and instructional environment for athletes to train simultaneously. Please note the heavy emphasis on the word SPORT. This concept was started by legendary strength coach Steve Kenyon, who has spent 40 years training athletes. Rae Crowther Sport Training Weight Rooms create space and greatly improve functionality. The Sport Training methodology centers around the YES, YES, YES philosophy. Yes to exercises performed with free weights, Yes to exercises performed standing, Yes to multiple joint movements.

What Specifically is a Sport Training Weight Room?

A Sport Training Weight Room begins with a perimeter rack design. The Elite Athlete Racks are placed around the outside of the room, on the perimeter of the room, which clears a large open space in the center of the room for various strength movements, speed, agility and of course coaching. This allows the coach to 'coach' from the center of the room and command the room accordingly. No athlete is hidden. Typically we paint line and agility patterns in the center space, so there is no need to fold and unfold ladders, no wasted time. We do all of this working within your budget. We can provide weight rooms from \$20,000 to \$200,000. You let us know how much "wow" factor you want and we supply the saucer! We have supplied over 80 Sport Training Weight Rooms in the last 10 years.

What Is Special About the Elite Athlete Rack and the Sport Training Racks?

We begin with the challenge of the High School football or strength coach who has to train 30 to 100 athletes simultaneously. The second part of that challenge is it often has to be done in a weight room that is not large enough to accommodate all of those athletes. We begin by creating space and organization. The Elite Athlete Rack is critical to this design implementation. At its most basic level a Elite Athlete Rack is essentially a simple device that holds a barbell. At its most advanced level it's a weight room in itself, in that it can allow multiple athletes to perform hundreds of diverse exercises. The primary focus of the Elite Athlete Rack is to increase maximum strength with an emphasis on ground based explosive movements. Movements that load the musculature and promote functional strength that enable athletes to run faster, hit harder, jump higher, and avoid injury. We specialize in flush-to-the-floor racks and platforms that allow athletes to move inside the weight room unobstructed. The racks don't have feet or runners sticking out into the lifting area. This increases the usable space on the floor about 3 feet per rack. 10 racks gain 30 feet, a big improvement in space. The platforms are made from wood, not rubber, and sink flush into the floor, with no edges. The athletes perform most of their lifts on wood. Our uncluttered designs allow athletes to work on unlimited strength and movements patterns. In effect, we make the typical 2,000 square foot weight room feel like a 3,500 square foot weight room. This also translates to better organization and little maintenance.

What Are the Killer B's?

The Killer B's are essential to the implementation of Sport Training Weight Room. The Killer B's are bars, bumper plates, med balls, wall balls, slam balls, dumbbells, bands, plyo boxes. Each rack has its own set of Killer B's, or in some instances 2 racks share a set of Killer B's. The Killer B's allow the coach and athlete a 100+ exercise menu. All the Killer B's have their exact storage location with specifically made racks that are engineered to go with the whole system.

How Do I Start?

Turn the page for more details and then call us. We will discuss your needs and dimensions of your room. We then provide a line item quote of everything you desire. We can also provide a detailed CAD drawing of what your future room would look like. We can turn-key the room for you or provide just the basics. It all starts with a conversation.

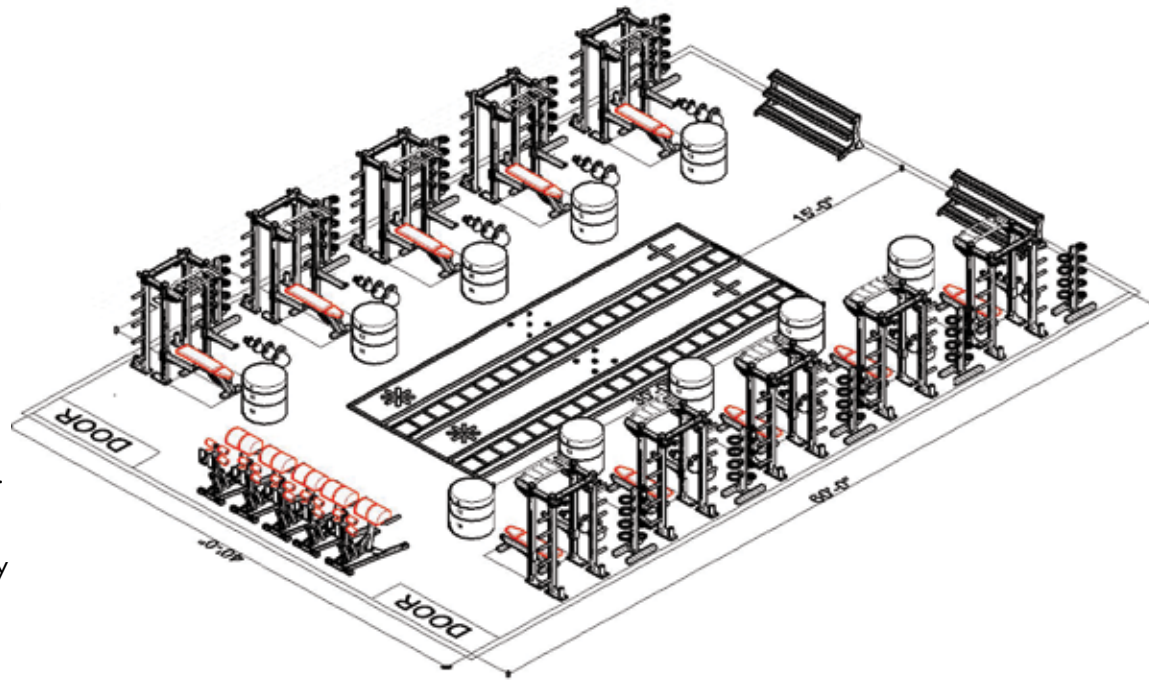

THE SYSTEM BOOK - THE 100 BEST EXERCISES

It's here! The new 2017-2018 Speed and Strength Conditioning manual. A comprehensive strength and conditioning manual for high school athletes. The system is a stepwise, sequential, progressive program for high school physical education and athletics designed to optimize athletic performance. The System trains movements and not muscles. The System trains through the season, not just to the season. The System gives the coach "a lot of tools in the coaching toolbox." The essence of the system is variation by design. Variation, intensity, technique. Although the units of training are sequenced following sound physiological principles, the exercise selection varies from day to day. The manual contains the following information:

Rubrics - Used by the coach, the rubric is the basis of evaluation from a performance and an academic standpoint. The rubrics for the "Big 100" exercises form the foundation of the system.

Metrics - How much, how many, how fast, how far: The system incorporates multiple measurements to create accountability and responsibility in students and athletes in their daily training.

Testing - The system uses The Physical Performance Profile to create baseline values of physical performance. Performed in the first week of the fall and spring cycle, these tests give the coach, student and athlete the present level of performance for upper body explosivity (seated medball throw), lower body static explosivity (vertical jump), lower body dynamic explosivity (standing broad jump), lateral speed and agility (pro agility) and speed (40 yard dash).

Exercises And Video - There are ten exercises per unit of training. Known collectively as the "The Big 100," think of these exercises as if they were the menu in a restaurant: A finite number of exercises that would be regularly if not randomly "selected" by the "customer." Virtually all of the exercises are accompanied by video that shows the exercises in real time and slow motion, and multiple angles. These videos are accessed on line with a pass code that is included with the purchase of The System.

Macrocycle - The system consists of a year round training program with weeks of active rest. There is a Fall Cycle that lasts from August 20th until December 20th, a Spring Cycle that lasts from January 10th to June 1st and a Summer cycle that starts on June 15th and ends on August 1st.

Microcycle - There are five sessions per week in one Microcycle. Monday, Wednesday and Friday sessions are primarily weightroom based. Tuesday and Thursday sessions are typically designed for the indoor gym, field or track.

Sessions - There are ninety sessions in a Mesocycle. The first five sessions of the fall and spring mesocycle include the Physical Performance Profile (PPP). The summer mesocycle does not include a PPP. It is a compilation of the "best of the best" 40 sessions.

Model: SST-BK

Price: \$199

We have been using elements of the SST system at Cedar Grove for three years. We are a small school and a lot of our athletes play multiple sports. In the last two years, we have won two state track championships and been to the Quarterfinals and Semifinals in basketball. This year, we won the first state championship in football in school history. I can't say enough great things about the SST principles we've used to improve athletic performance and to keep our athletes relatively injury-free. Huge thanks to Coach Kenyon! Go Saints!



Overhead Squat *

5	feet are shoulders width; toes slightly wider than the heels; bar is locked out above head. Exercise begins with flexion at the hip, knee and ankle; eyes remain level. Squat position is well below parallel; notch of hip is below top of the knee. Exercise ends with full extension of hip, knee and ankle. Back angle remains flat during exercise; bar remains stable during exercise.
	feet are shoulders width; toes slightly wider than the heels; bar is held high on shoulder. Exercise begins with flexion at the hip, knee and ankle; eyes remain level. Squat position is below parallel. Exercise ends with full extension of hip, knee and ankle. Back angle remains flat during exercise; bar remains stable during exercise.
4	feet are shoulders width; toes slightly wider than the heels; bar is held high on shoulder. Exercise begins with flexion at the hip, knee and ankle; eyes may not be level. Squat position is parallel. Exercise ends with full extension of hip, knee and ankle. Back angle remains flat during exercise; bar remains stable during exercise.
	feet are shoulders width; toes slightly wider than the heels; bar is held high on shoulder. Exercise begins with flexion at the hip, knee and ankle; eyes may not be level. Squat position is parallel. Exercise ends with full extension of hip, knee and ankle. Back angle remains flat during exercise; bar remains stable during exercise.
3	feet are shoulders width; toes slightly wider than the heels; bar is held high on shoulder. Exercise begins with flexion at the hip, knee and ankle; eyes may not be level. Squat position is parallel. Exercise ends with full extension of hip, knee and ankle. Back angle remains flat during exercise; bar remains stable during exercise.
	feet are shoulders width; toes slightly wider than the heels; bar is held high on shoulder. Exercise begins with flexion at the hip, knee and ankle; eyes may not be level. Squat position is parallel. Exercise ends with full extension of hip, knee and ankle. Back angle remains flat during exercise; bar remains stable during exercise.

Optimizing Athletic Performance
82

the system™ session #90

unit	exercise	sets	x	reps
DWU	Walking lunge	2	x	10 yards
	Slow cariocca	2	x	10 yards
	High kick	2	x	10 yards
TEC	Push press	5	x	5
e ¹	Clean (Challenge #6)	2	x	3
		3	x	2
		5	x	1
Last three sets at 90%, 95% and 100% of 1 RM				
STAB	Stick hop	5	x	5
CORE	Turkish get-up	3	x	10
DROM	Across and out	1	x	10
	Front swing	1	x	10
	Side swing	1	x	10

800-841-5000 122 www.raecrowther.com

ELITE ATHLETE RACK (E.A.R.)

The new Elite Athlete Rack (E.A.R.) is made for the coach and athlete who want to maximize their training space with ground based exercise movements. The E.A.R. is the antonym to the expensive and bulky power rack. With the E.A.R concept the weight room can be simplified, space efficiency greatly increased, and costs reduced. The E.A.R. allows more athletes to train simultaneously.

Uprights

The E.A.R is made from 11 Gauge structural 3" steel tubing. The uprights are lasered with 1 1/8" holes that allow 2" bar catch adjustments. Numbers are laser cut on both sides of the uprights. Lasered numbers will not wear out like panels or decals. Each upright has 20" x 6" x 3/8" welded base plates. All base plates have welded gussets for strength. Each base plate has 4 holes for mounting into the floor (the rack must be bolted into the floor, not free standing).

Deluxe Bar Catches

Standard are two Patriot Deluxe Bar Catches with 34 adjustments per upright. The catch is a "sandwich" style bar catch with 1" thick ultra-high dense plastic in the middle. The metal is lasered cut and formed. The bar rests on the plastic and never the metal. The lifter has 3" of plastic to rest the bar. The interior of the catch is protected from the upright with a plastic sleeve.

Chin Bar & Safety Bars

The cambered Chin Bar is made from 1 3/8" metal rod with rubber grips. The chin bar has two wide interior parallel grip areas. The Chin bar connector is gusseted and welded with large end plates for extra strength. Standard are two (2) heavy duty safety bars (safeties are painted matte crinkle black). Each bar is 24" in length. Each safety has hard plastic protection on the top of the metal. The plastic is secured with button head bolts and not glue. Each safety is made from 3" structural steel tubing and gusseted for extra strength.

Powder coated in matte crinkle black. Kept in stock for fast delivery!

Model: EAR1
Price: \$1095

Order 2-3 Racks and save 5% (\$1040)
Order 4-7 Racks and save 10% (\$985)
Order 8+ Racks and save 15% (\$931)

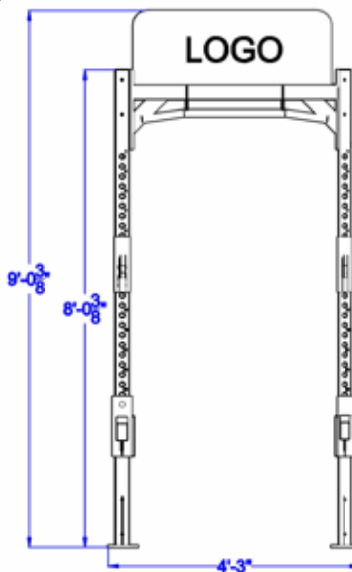
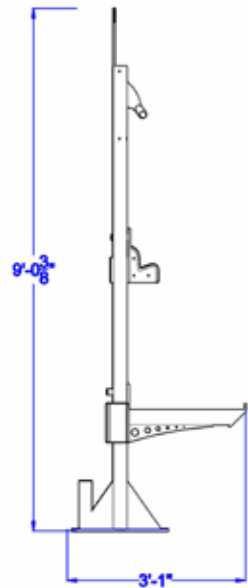
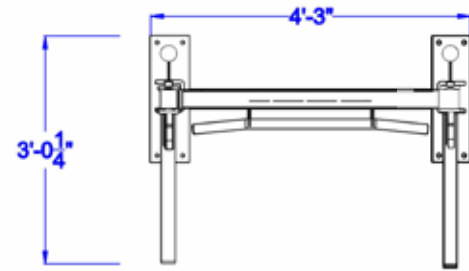

Order 24/7 at www.raecrowther.com

ROLLED RUBBER FLOORING



Specifically designed to be the best flooring in safety and performance. Designed for its load carrying capacity, flexibility and strength. It is not slick when dusty. Rubber flooring provides unmatched performance for training. Creates a professional look. Easy maintenance. Available in plain black or speckled colors.

Model: RB100-3/8
Price: \$475 per 50' roll

PRO GOLD ADJUSTABLE BENCH



A great rock-solid bench that is easy to use and very durable.

Model: 1080 **Price:** \$845
Order 4 or more and save 15% (\$718)



FAX: 803-366-3633

ELITE ATHLETE RACK (E.A.R.) OPTIONS

IN-GROUND PLATFORM (4' X 4' X 3/8")



For Olympic lifts, nothing beats lifting off wood. 3/8" x 4' wood platform that is designed to sit flush to the floor, requires 3/8" rubber flooring. Price includes logo. Creates a real "wow!" factor to your weight-room.

Model: PRO1A
Price: \$399 per platform
Order 4 or more and save 15% (\$339)

LINE AND PATTERN STRIPING



Create custom designs or use our templates for ladders, dots, cross, and star patterns. Invaluable for creating an efficient drill space for agility and speed work. (For stencil kits, see the section at the back of the catalog. Individual stencils can be purchased.)

Model: SST-LP
Price: Call for price

PRO BUMPER PLATE RACK



The spacing of the slots is as follows: Two slots spaced 6" apart, two slots spaced 4 1/2" apart, two slots spaced 2 1/2" apart. Standard color is matte crinkle black.

Model: 5155 **Price:** \$249
Order 4 or more and save 15% (\$212)

DOUBLE-SIDED MED-BALL RACK

Nuclear-strength med-ball rack made from 3" x 3" square tubing, and welded 1/2" brackets. Holds 4 wall balls and 5 slam balls. Rubber feet on all 4 corners. Standard color is matte crinkle black.

Model: MBR3 **Price:** \$295
Order 4 or more and save 15% (\$251)



For more information on sport training philosophy, please go to our website and watch the videos on the following topics:

- The Training Element
- Essence of the Program
- Dynamic Warmup
- Train to Play
- Speed Windows
- Rest Relief
- Technical Speed
- Injury Prevention
- One Coach 50 Kids
- 6 Key Exercises
- Lift and Run
- What if they have a Game Tonight?
- Weight Rooms without Equipment

Call Toll-Free: 800-841-5050

PATRIOT HALF RACK

Model: PAT2

Price: \$1895

Special Deals:

2-3 Racks and save 5% (\$1799)

4-7 Racks and save 10% (\$1705)

8+ Racks and save 15% (\$1611)



PATRIOT PLATFORM

This platform uses 3/16" metal framing with rubber matting. Rubber is 1 1/2" thick (2 layers of matting). The rack sits on top of the frame and bolts to the back of the platform. 8' W x 12' L x 2" H.

Model: PRO-PF

Price: \$1750

Special Deals:

2-3 Platforms and save 5% (\$1662)

4-7 Platforms and save 10% (\$1575)

8+ Platforms and save 15% (\$1487)

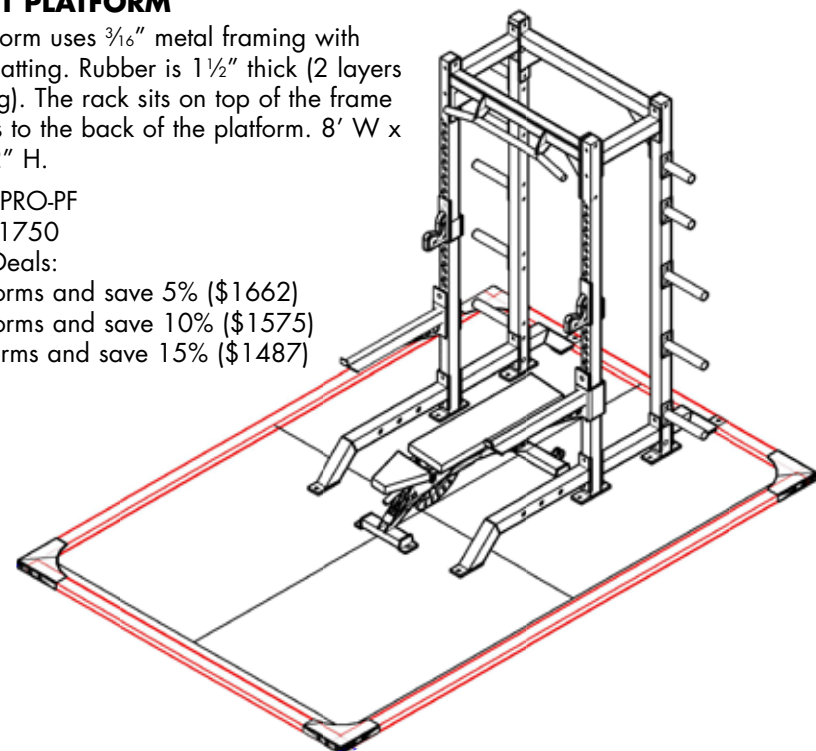

PATRIOT POWER RACK

Model: PAT4

Price: \$2595

Special Deals:

2-3 Racks and save 5% (\$2465)

4-7 Racks and save 10% (\$2335)

8+ Racks and save 15% (\$2206)



PATRIOT DOUBLE RACK

Model: PAT3

Price: \$2999

Special Deals:

2-3 Racks and save 5% (\$2849)

4-7 Racks and save 10% (\$2699)

8+ Racks and save 15% (\$2549)

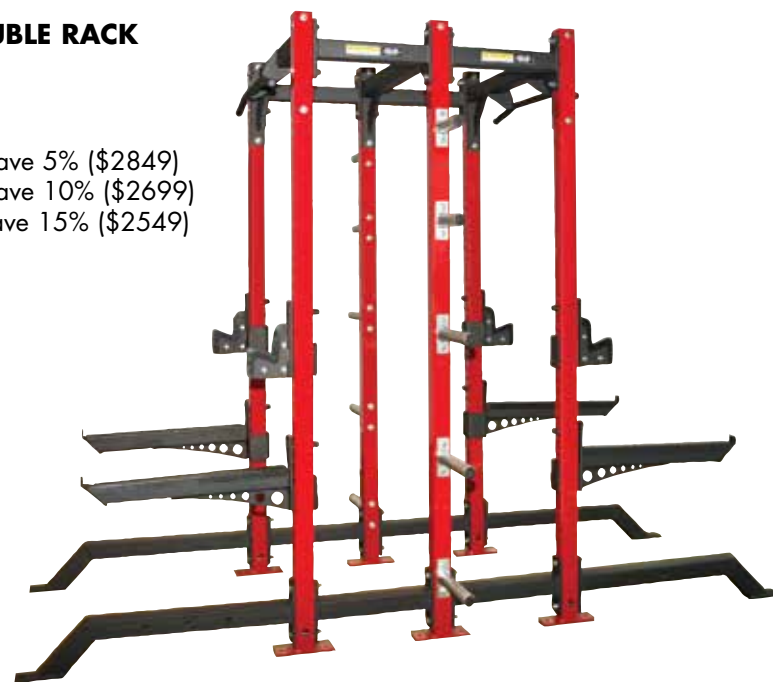

PATRIOT RACKS

Patriot Uprights

Patriot Racks are made from 11 Gauge structural 3" steel tubing. The uprights are lasered 1 1/8" holes that allow 2" bar catch adjustments. Numbers are laser cut on both sides of the uprights. Lasered numbers will not wear out like panels or decals. Choose among 14 Standard colors for the uprights: Gloss Black, Matte Crinkle Black, Light Gray, Silver, White, Red, Maroon, Purple, Orange, Yellow, Navy Blue, Royal Blue, Dark Green, Kelly Green.

Patriot Deluxe Bar Catches

Standard are Patriot Deluxe Bar Catches with 34 adjustments per upright. The catch is a "sandwich" style bar catch with 1" thick ultra-high dense plastic in the middle. The metal is lasered cut and formed. The bar rests on the plastic and never the metal. The lifter has 3" of plastic to rest the bar upon. The interior of the catch is protected from the upright with a plastic sleeve. The catch is painted matte crinkle black.

Patriot Chin Bar

The Chin Bar is made from 1 3/8" metal rod with a small camber at both ends. The chin bar has two wide interior parallel grip areas. The chin bar connector is gusseted and welded with large end plates for extra strength.

Patriot Weight Horn Uprights

Standard are ten (10) zinc plated weight horns that bolt to the back uprights. Bumper plates will fit on the lower 3 weight horn pins. The Bottom 3 weight horn pins are 12" long and the top 2 pins are 6" long.

Patriot Safety Bars

Standard are two (2) heavy duty safety bars (safeties are painted matte crinkle black). Each bar is 29" in length. Each safety has hard plastic protection on the top and side of the metal. The plastic is secured with 2 metal rivets. Each safety is made from 3" structural steel tubing and gusseted for extra strength.

Patriot Sumo Base

Each rack comes standard with a Sumo base. On the Half and Double rack the Sumo attaches to the front of the rack and is predrilled with three holes (1 1/8" dia.) on 2" centers to accept band pegs or utility pins.

Patriot Rack Connectors/Bracing

The connectors on the rack are heavily gusseted with 3" square tubing and 1/2" thick endplates. These heavy gussets, two (2) on top, one (1) on bottom, with large oversized endplates are what make the rack very-very rigid.

OPTIONS:

Bar Holder

Model: PRO26

Price: \$85

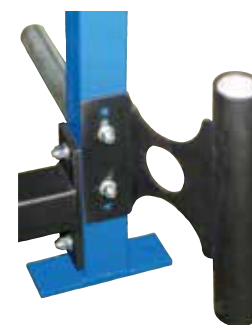

Landmine

Model: PRO24

Price: \$125



Storage Hook

Model: PRO20

Price: \$48



Utility Pin

Model: PRO23

Price: \$32



Dip Attachment

Model: PRO19

Price: \$295





For more information on sport training philosophy, please go to our website and watch the videos on the following topics:

- The Training Element
- Essence of the Program
- Dynamic Warmup
- Train to Play
- Weight Rooms without Equipment
- Speed Windows
- Rest Relief
- Technical Speed
- Injury Prevention
- One Coach 50 Kids
- 6 Key Exercises
- Lift and Run
- What if they have a Game Tonight?

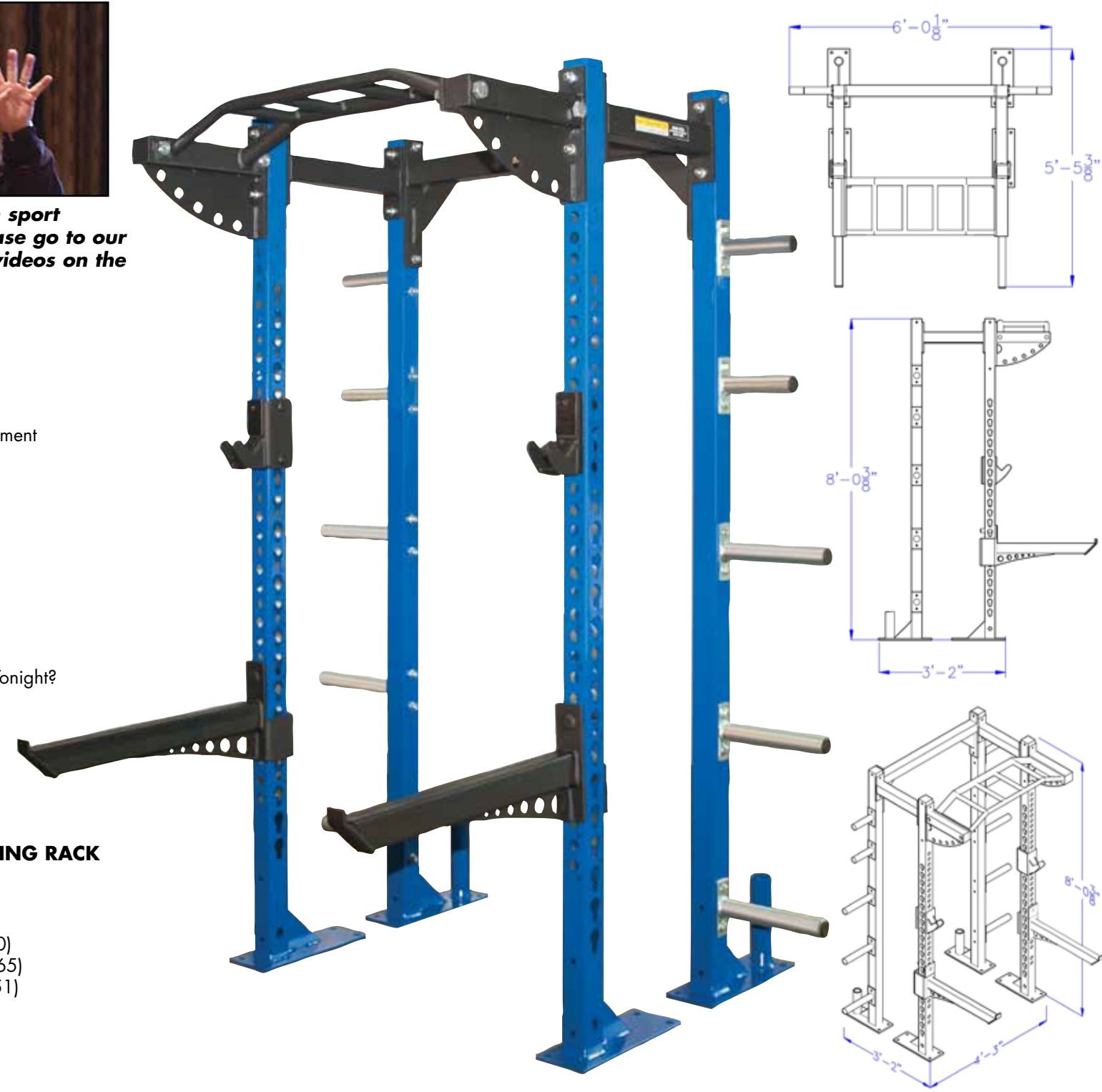

PRO GOLD SPORT TRAINING RACK

Model: PRO1

Price: \$2295

Order:

2-3 Racks and save 5% (\$2180)

4-7 Racks and save 10% (\$2065)

8+ Racks and save 15% (\$1951)

Order 24/7 at www.raecrowther.com

PRO GOLD SPORT TRAINING RACK

The Pro Gold Sport Training Rack is the best of the best and the leader in functionality and space savings. With no ground runners extending into the lifting area, these racks create a flush-to-the-floor design (with 3/8" rubber flooring). Pro Gold Racks include 7 Gauge 3" structural steel tubing. The Uprights are lasered with a Tear Drop & Hole design. The Pro Gold Series utilizes a multi-use upright. The tear drop design is lasered on the outside & inside of the uprights. These Laser cut tear drops allow micro 1 1/2" on center bar adjustments. On the front & backside of the uprights are 1 1/8" holes that are spaced 2" on centers. The dual design allows the lifter many options and many accessories. The uprights are pre-drilled to accept our Landmine Attachment. Each upright has 16" x 6" x 3/8" welded base plates. All base plates have welded gussets for strength. Each base plate has 4 holes for mounting into the floor. Choose among 14 Standard colors for the uprights: Gloss Black, Matte Crinkle Black, Light Gray, Silver, White, Red, Maroon, Purple, Orange, Yellow, Navy Blue, Royal Blue, Dark Green, Kelly Green.

Pro Gold Monkey Chin Bar

Pro Gold Racks come standard with the Monkey Chin Bar(s) with Extended Porch (72 lbs.). The Monkey Chin Bar provides the ultimate body weight experience. The design incorporates 2 chin bars of different sizes and 4 parallel grip areas. The front & back chin bars are of different diameters. The front bar is 1 3/8" diameter; the back bar, or 'fat bar' is 2" diameter. The bar is 42" wide. The parallel grips are spaced 10" & 24" apart. The extended porch area allows the Monkey Bar to be attached in front of the rack, as opposed to the interior of the rack, this allows more interior room & exercise combinations. The Porch also has pre-drilled holes for utility pin attachments. The top of the Monkey Bar is 96" from the floor. The Monkey Bar can be mounted 'upside down.' In this case the floor to chin bar height is 86". The Monkey is painted matte crinkle black for grip & durability. The connectors on the rack are heavily gusseted with 3" square tubing and 1/2" thick endplates. These heavy gussets with large oversized endplates are what make the rack very-very rigid.

Pro Gold Bar Catches

Pro Gold racks come standard with Deluxe Bar Catches with Roller Tappets (14 lbs. each). The Deluxe Bar Catch features a dual plate hook for safety & a roller tappet that makes centering a heavily loaded bar easier (the bar rolls on the tappets instead of grinding on metal). The Deluxe Catch also has hard plastic protection on the strike plate to keep the bar from grinding on any metal surfaces. The plastic is secured with counter sunk screws and is not glued. The drop-in latch utilizes a dual pin design for security and ease of movement. Each pin is machined for a perfect "fit" to the upright. The bar catches are reversible & can be used on the left or right side of the uprights, or inside or outside of the rack. This design element provides the user with many training options. The maximum height of the bar catch adjustment is 72" from the ground. Plastic protection is also used inside of the latch to protect the uprights. Painted matte crinkle black.

Pro Gold Weight Horns

Standard are ten (10) zinc plated weight horns that bolt to the back uprights. Bumper plates will fit on the lower 3 weight horn pins. The Bottom 3 weight horn pins are 12" long and the top 2 pins are 6" long.

Pro Gold Safety Bars

Each rack includes deluxe 29" safety bars. Each safety has hard plastic protection on the top & sides. The plastic is screwed to the metal & not glued. Each safety is made from 3" structural steel tubing and is welded and gusseted for strength. The drop-in design is the same as the Bar Catch. Minimum height of safety from ground is 14". Weight 17 lbs. per safety.

OPTIONS:

In-Ground Platform (4' x 4' x 3/8")

Model: PRO1A

Price: \$399

(Platform includes custom Logo)



Awesome Adjustable Bench

Model: 1080

Price: \$845



Double-Sided Med-Ball Rack

Model: MBR3

Price: \$295



Dip Attachment

Model: PRO19

Price: \$295



FAX: 803-366-3633

Call Toll-Free: 800-841-5050

PRO GOLD HALF RACK

Model: PRO2

Price: \$2495

Special Deals:

2-3 Racks and save 5% (\$2370)

4-7 Racks and save 10% (\$2245)

8+ Racks and save 15% (\$2121)



PRO GOLD PLATFORM

This platform uses 3/16" metal framing with rubber matting. Rubber is 1 1/2" thick (2 layers of matting). The rack sits on top of the frame and bolts to the back of the platform. 8' W x 12' L x 2" H.

Model: PRO-PF

Price: \$1750

Special Deals:

2-3 Platforms and save 5% (\$1662)

4-7 Platforms and save 10% (\$1575)

8+ Platforms and save 15% (\$1487)

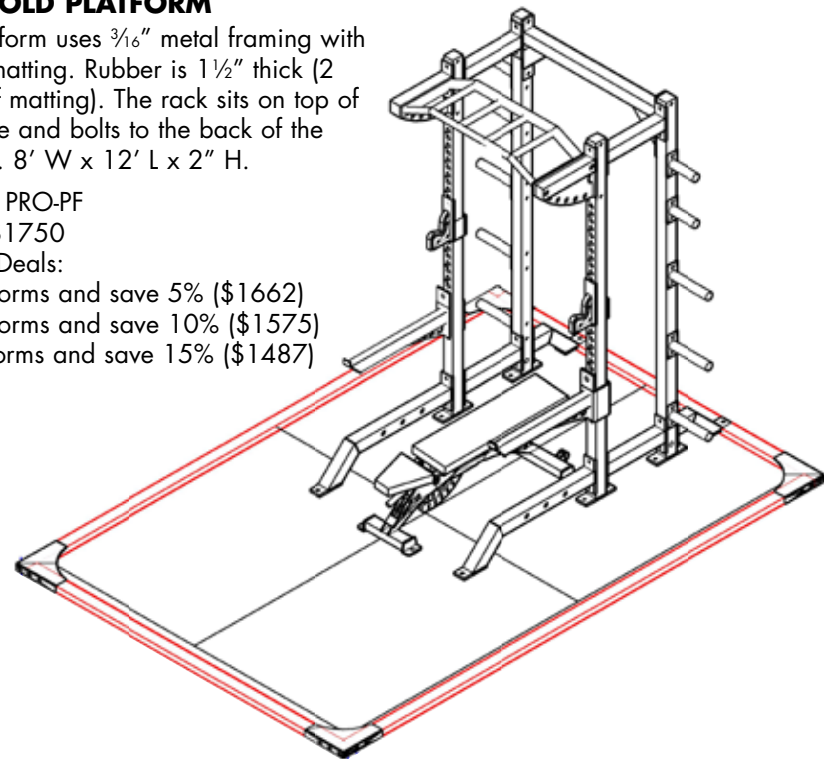

PRO GOLD POWER RACK

Model: PRO4

Price: \$3295

Special Deals:

2-3 Racks and save 5% (\$3130)

4-7 Racks and save 10% (\$2965)

8+ Racks and save 15% (\$2801)



PRO GOLD DOUBLE RACK

Model: PRO3

Price: \$3995

Special Deals:

2-3 Racks and save 5% (\$3795)

4-7 Racks and save 10% (\$3595)

8+ Racks and save 15% (\$3395)



PRO GOLD RACKS

Pro Gold Racks include 7 Gauge 3" structural steel tubing, lasered with a Tear Drop & Hole design. The Pro Gold Series utilizes a multi-use tear drop upright, lasered on the outside & inside. These laser cut tear drops allow micro 1 1/2" on center bar adjustments. On the front & backside of the uprights are 1 1/8" holes that are spaced 2" on centers. The dual design allows the lifter many options and many accessories. The uprights are pre-drilled to accept our Landmine Attachment. Choose among 14 Standard colors for the uprights: Gloss Black, Matte Crinkle Black, Light Gray, Silver, White, Red, Maroon, Purple, Orange, Yellow, Navy Blue, Royal Blue, Dark Green, Kelly Green.

Pro Gold Monkey Chin Bar

Pro Gold Racks come standard with the Monkey Chin Bar(s) with Extended Porch (72 lbs.). The Monkey Chin Bar provides the ultimate body weight experience. The design incorporates 2 chin bars of different sizes and 4 parallel grip areas. The front & back chin bars are of different diameters. The front bar is 1 3/8" diameter; the back bar, or 'fat bar' is 2" diameter. The bar is 42" wide. The parallel grips are spaced 10" & 24" apart. The extended porch area allows the Monkey Bar to be attached in front of the rack, as opposed to the interior of the rack, this allows more interior room & exercise combinations. The Porch also has pre-drilled holes for utility pin attachments. The Monkey Bar is painted matte crinkle black for grip & durability.

Pro Gold Bar Catches

Pro Gold racks come standard with Deluxe Bar Catches with Roller Tappets (14 lbs. each). They feature a dual plate hook for safety & a roller tappet that makes centering a heavily loaded bar easier (the bar rolls on the tappets instead of grinding on metal). The Deluxe Catch also has hard plastic protection on the strike plate to keep the bar from grinding on metal. The plastic is secured with counter sunk screws and is not glued. The drop-in latch has a dual pin design for security and ease of movement. Each pin is machined for a perfect "fit" to the upright. The bar catches are reversible & can be used on the left or right side of the uprights, or inside or outside of the rack. This design element provides the user with many training options. Plastic protection is also used inside of the latch to protect the uprights. Painted matte crinkle black.

Pro Gold Weight Horns

Standard are ten (10) zinc plated weight horns that bolt to the back uprights. Bumper plates will fit on the lower 3 weight horn pins. The Bottom 3 weight horn pins are 12" long and the top 2 pins are 6" long.

Pro Gold Safety Bars

Each rack includes deluxe 29" safety bars. Each safety has hard plastic protection on the top & sides. The plastic is screwed to the metal & not glued. Each safety is made from 3" structural steel tubing and is welded and gusseted for strength. The drop-in design is the same as the Bar Catch. Minimum height of safety from ground is 14". Weight 17 lbs. per safety.

Pro Gold Sumo Base And Connectors

Each rack comes standard with a Sumo base. The Half and Double Sided rack has the sumo attached to the front side of each rack and is predrilled with three holes (1 1/8" dia.) on 2" centers to accept band pegs or utility pins. The connectors on the rack are heavily gusseted with 3" square tubing and 1/2" thick endplates. These heavy gussets with large oversized endplates are what make the rack very-very rigid.

OPTIONS:

Bar Holder
Model: PRO26
Price: \$85

Landmine
Model: PRO24
Price: \$125

Storage Hook
Model: PRO20
Price: \$48

Utility Pin
Model: PRO23
Price: \$32

Dip Attachment
Model: PRO19
Price: \$295



PRO GOLD UTILITY BENCH

The Pro Gold Utility Bench is a pleasure to train with and a reliable partner in the weight room. Comfortable, functional, heavy duty, easy to adjust, and easy to move. The back pad is 10" wide x 38" long and the wedge shaped butt seat is 13" long and tapers 10" wide x 6". There are 9 angles of adjustment for the back pad and 6 angles of adjustment for the butt seat (1 of the positions is the decline adjustment). The standard decline angle is 45 degrees. The front seat goes to minus 20 degrees to 40 positive degrees. The rear pad adjusts from 0-85 degrees, a more natural upright position. For movement of the bench, two hard rubber wheels are mounted to steel welded mounts. Warranty: Frame 5 years, Padding 1 year. L 52" x W 24" x H 18". Weight 125 lb. Standard frame and pad color is Black.

Model: 1080
Price: \$845

Order 2 or more and save 10% [\$760].
Order 4 or more and save 15% [\$718].



ADJUSTABLE UTILITY BENCH

The adjustable utility bench has 5 positions: 30, 45, 60, and 80 degrees. The handle and wheels make this bench easily transportable. Bench has firm padding on 3/4" plywood with double stitching. Weight: 77 lbs. 18" H x 24" W x 49" L. Pad color: Black. Paint color: Black

Model: WE11 **Price:** \$595



VARSITY FLAT UTILITY BENCH

This is a fixed position bench, constructed of 11 gauge x 2" square tubing. The bench has firm vinyl covered foam padding on 3/4" plywood. Color: black-on-black. 18" H x 16" W x 48" L x 45 lb.

Model: WE100 **Price:** \$195



LAT PULL DOWN

Adjustable locking leg hold-down secures the lifter in place. Straight bar with angled ends ensures correct arm and wrist position. 4200 lb. tensile strength aircraft quality cable. Choose between 250 or 300 lb. weight stacks. Dimensions: 53" L x 47 1/2" W x 90" H. 537 lbs. Pad Color: Black. Frame Color: White or Silver. Call for custom color.

Model: 54020 with 250 lb. Stack **Price:** \$1695
Model: 54021 with 300 lb. Stack **Price:** \$1795



LOW ROW

Excellent for mid to upper back exercises. Step-through design for easy access. 4200 pound tensile strength aircraft quality cable. Large diamond-plate footplate ensures foot stability. Rubber covered machine attachment rest improves bar accessibility and protects equipment finish. Choose between 250 or 300 lb. weight stacks. Dimensions: 72" L x 30 1/4" W x 90" H. 590 lbs. Pad Color: Black. Frame Color: White or Silver. Call for custom color.

Model: 54018 with 250 lb. Stack **Price:** \$1895
Model: 54019 with 300 lb. Stack **Price:** \$1995



TRICEP ROPE W/SOLID RUBBER ENDS
Model: ATR36 **Price:** \$35



MULTI EXERCISE BAR
Model: TXB **Price:** \$40



HEAVY DUTY SINGLE CABLE HANDLE
Model: TCCH-D (2.7 lbs) **Price:** \$36



REVOLVING STIRRUP HANDLE
Model: TOCHS (2 lbs) **Price:** \$30



TRICEP PRESS DOWN BAR W/SWIVEL
Model: TTVB-S **Price:** \$40



CHIN TRIANGLE DOUBLE LOW ROW WITH ERGO HANDLE
Model: GCT **Price:** \$29



SINGLE CABLE GRIP ERGO HANDLE
Model: GCCH **Price:** \$20



REVOLVING STIRRUP HANDLE W/RUBBER GRIP
Model: TCCHR (2 lbs) **Price:** \$36



TRICEP PRESS DOWN BAR
Model: GTVB **Price:** \$24



DOUBLE STIRRUP HANDLE
Model: TDSH (6 lbs) **Price:** \$45



48" HIGH QUALITY LAT BAR WITH SWIVEL
Model: TLB-48S (9.5 lbs) **Price:** \$49



20" MULTI PURPOSE STRAIGHT BAR
Model: GSB-20S (5.28 lbs) **Price:** \$35



28" MULTI PURPOSE CURL BAR
Model: GCB-28S (8.03 lbs) **Price:** \$38



48" LAT BAR WITH SWIVEL AND RUBBER GRIPS
Model: GLB-48SR (9.5 lbs) **Price:** \$50



20" MULTI PURPOSE STRAIGHT BAR WITH RUBBER GRIPS
Model: GSB-20SR (5.28 lbs) **Price:** \$36



28" MULTI PURPOSE CURL BAR WITH RUBBER GRIPS
Model: GCB-28SR (8.03 lbs) **Price:** \$40



34" PRO STYLE LAT BAR WITH FORGED SWIVEL
Model: TPLB-34S (10 lbs) **Price:** \$69



24" LAT BAR WITH FORGED SWIVEL
Model: TPLB-24S (9 lbs) **Price:** \$59

VARSITY GLUTE HAM:

Innovative design is a breakthrough in simplicity, durability, and functionality. A Glute Ham is a combination exercise; it is a back extension with a leg curl. The intent is for the Glute Ham raise to be similar to the posterior chain recruitment in sprinting. Our table top design is very stable. Oversized high-density foam thigh and knee pad is constructed without any wood or staples and can be easily removed for floor exercises. Extremely comfortable and stable design allows aggressive exercise. Split pad for male comfort. Pad also includes Velcro insert that can be installed back into the split part of the pad for core work. Standard features include med ball holder (fits Dynamax ball), band attachment, 9" diameter never-go-flat wheels for easy movement, and oversized rubber feet. The band attachment doubles as a handle for moving the machine. For video, go to raecrowther.com. No pop pins or difficult sliding mechanisms. Adjustable foot plate pivots forward and backward to accommodate different size athletes (will fit athletes from 4'5" to 6'8" in height). The pivoting arm is protected in plastic; thus no metal-to-metal contact. Powder coated in a scuff resistant formula. Standard color: Matte Crinkle Black. Standard pad color is black. 3 year warranty. Ships fully assembled. Weighs 202 lb. 60" L x 38" W x 46" H.

Model: GLH **Price:** \$795
Order 2 or more and save 10% (\$715)

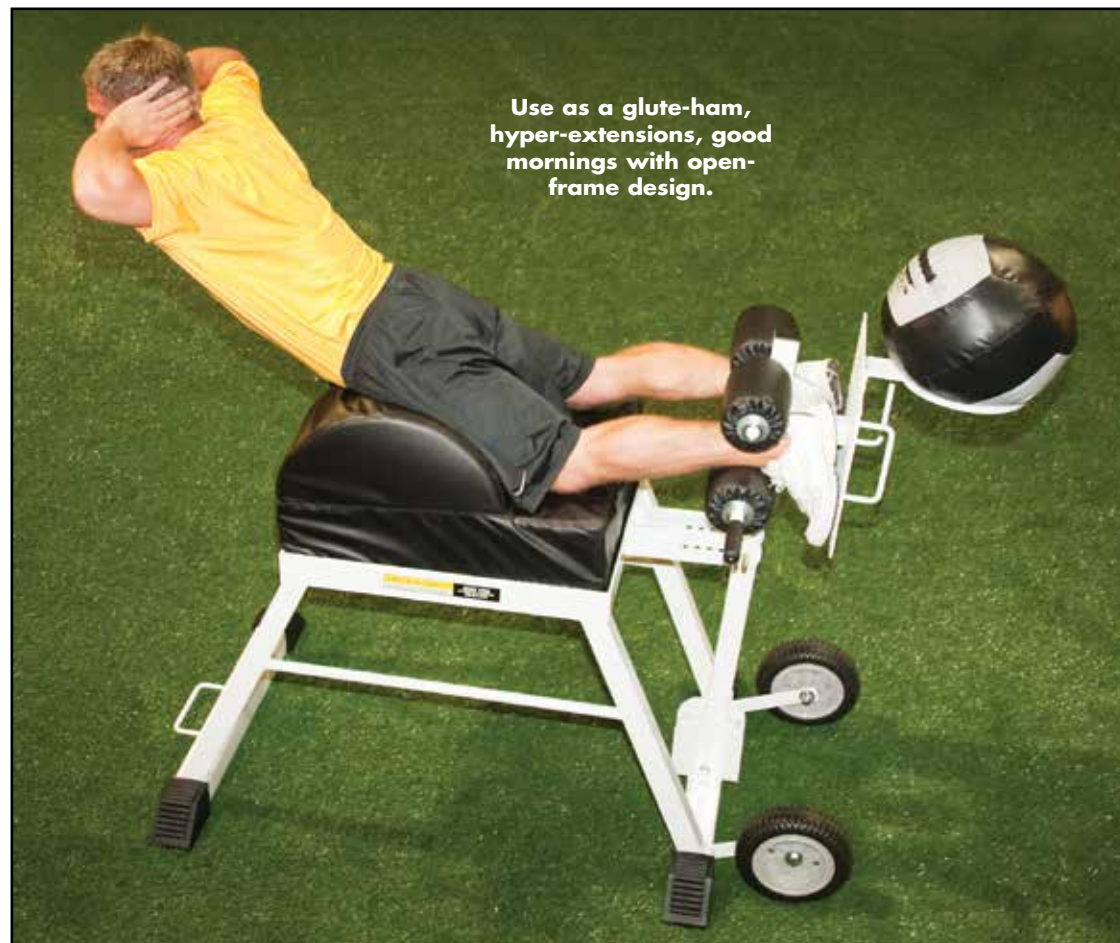

Use as a glute-ham, hyper-extensions, good mornings with open-frame design.



202 lb
MACHINE
WEIGHT

FLOOR MODEL GLUTE HAM (SHOWN BELOW)

Also known as a "Partner Glute Ham," use this economical pad for glute ham and core work. Our model uses the heaviest weighted foam in the industry. Removable center pad. Covered in black vinyl.

Model: GLH-F **Price:** \$225
Order 2-3 and save 10% (\$202)
Order 4 or more and save 15% (\$191)



VARSITY LEG EXT LEG CURL

This is a dual function machine. Use as a leg extension or as a leg curl. Fixed backrest allows a very quick transition between exercises. 2 handles with rubber grips for lock-in during heavy leg extensions. Can load up to six 45" plates. Plate holder is UHMW protected. Molded rubber feet at all four corners. 59" long x 30" wide. Made primarily from 3" structural square tubing. Standard frame color: Matte Crinkle Black.

Model: LELC **Price:** \$895



151 lb
MACHINE
WEIGHT



VARSITY 4-WAY NECK MACHINE

Waste no time getting situated with our 4 angle Neck Machine. To change the angle of attack (anterior flexion, posterior flexion and lateral contraction) the athlete simply turns 45 degrees on the seat. Simple and easy with no complicated adjustments. Rotates on a sealed ball bearing. Holds up to 135 lb. 4

hand grips for each angle. Dual design padded headrest is easy and comfortable. Seat height is adjustable and spring loaded. Two UHMW protected plate holders. Molded rubber feet at all four corners. 60" tall x 43" length x 25" width. Made primarily from 3" structural square tubing. Standard pad color is black. Standard frame color: Matte Crinkle Black.

Model: NKM **Price:** \$895



391 lb
MACHINE
WEIGHT



YORK 7' NORTH AMERICAN 28 MM CHROME BAR - a great all-purpose training bar

York applied its vast knowledge in bar design and produced perhaps the highest quality, most functional and attractive Olympic Bar of today. York applied its signature "split sleeve" design to each bar, which replaces the outmoded bolt and sleeve assembly. This means the sleeve assembly will not loosen or detach. The needle bearings ensure smooth, consistent rotation of the sleeves. The steel used in both bars is produced in North America. The Men's Bar is 7' long. The Women's Bar is 6½' long.

Model: 32110 **Price:** \$329

Order 2 or more and save 10% (\$296), Order 4 or more and save 15% (\$279)



YORK 20 KG PRO OLYMPIC BAR - an excellent bar for serious Olympic lifting

York Bars are made from the highest grade steel with a minimum yield strength of 195,00 PSI. Bars are made from elevated temperature drawn high tensile steel for maximum strength and flexibility. Bar sleeves are machine finished with needle bearings for reduced friction. Bars are calibrated to be accurate to within +0.01% and -0.05%. Sleeves are machine finished to a precise 1.975" diameter, accommodating any 2" diameter Olympic plate.

Model: 32002 **Price:** \$439 (20 kg Bar)

Order 2 or more and save 10% (\$395), Order 4 or more and save 15% (\$373)



YORK 7' NORTH AMERICAN BLACK OXIDE BAR - a very good choice for power lifting

York 7' North American Black Oxide Bar 1500 lb. Test 32 mm

Model: 32120 **Price:** \$279

Order 2 or more and save 10% (\$251), Order 4 or more and save 15% (\$237)



YORK EXTREME FAT BAR - grip-strength training

7' York Extreme 2" Grip Olympic Bar "Fat Bar" 55 lbs.

Model: 2988 **Price:** \$295

Order 2 or more and save 10% (\$265), Order 4 or more and save 15% (\$250)



YORK INTERNATIONAL 15 LB. ULTRA-LITE 6' ALUMINUM BAR - a great youth bar

Model: 32032 **Price:** \$159

Order 2 or more and save 10% (\$143), Order 4 or more and save 15% (\$135)



HEX COMBO SHRUG BAR

Manufactured by the original designers of the Hex Bar. This hex bar is silver zinc with raised handles on the side for lifting or flat handles on the other side for low stress. This bar is indestructible and the #1 shrug bar sold.

Model: SBF16 **Price:** \$165

Order 2+ and save 10% **Price:** \$148

Order 4+ and save 15% **Price:** \$140

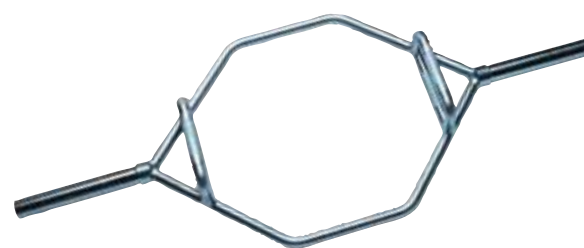

MEGA HEX BAR

When you outgrow the hex bar, try the mega hex with its 13" sleeves to carry more weight. 64" overall length by 24" wide. Bar weight is 75 lbs. It's made of 1¼" steel designed for your heavier lifters.

Model: SBF17 **Price:** \$275

Order 2+ and save 10% **Price:** \$247

Order 4+ and save 15% **Price:** \$233



MULTI GRIP BAR

This weight-lifting bar has 3 different hand positions for complete muscular development of the shoulders and chest. Ergonomic placement of hands helps reduce stress on shoulders and wrists during pressing exercises. Heat-treated alloy with knurled handgrips. Fixed sleeves. Black. Length: 84". Sleeve: 15¼". 58 lb.

Model: 50080 **Price:** \$299



YELLOW 5' PVC TEACHING BAR

Train your athletes on the Olympic lifts with our Yellow Teaching Pipe. Don't junk up your weight room with cheap breakable white PVC pipe. Instead use our high strength PVC tubing (5x stronger and more durable than plumbing-grade PVC). Cut to 5' length and 1" in diameter.

Model: BPVC **Price:** \$19



18 LB EZ CURL BAR

Model: TOZ-47B **Price:** \$110



LANDMINE

A ground-based rotational training device that works the entire body. Perform explosive 1- and 2-arm movements and other rotational exercises simply by inserting any Olympic-size bar (not included) into the 12" pivoting sleeve at the unit's base.

Model: LND1 Landmine Base (47 lbs) **Price:** \$239



CAMBERED SQUAT BAR

This bar allows squats to be done in a more vertical posture, producing intensified quadriceps involvement. Cambered end design relieves much of the lower back stress normally associated with a back squat. All steel design with padded shoulder harness.

Model: WT129 **Price:** \$379



SPRING COLLARS

Model: OC-O6

Price: \$10 per pair



MUSCLE CLAMPS

Model: AOMC

Price: \$45 per pair



LOCK-JAW COLLARS

Model: WT135

Price: \$55



VERTICAL BAR HOLDER

Model: 6916

Price: \$95



VARSITY LIFTING PLATFORM

This is a very economical and durable Olympic and dead-lift platform. All rubber construction with 2" square tube frame. 463 lb. Standard color: Matte Crinkle Black. Warranty: 3 Years on frame. Plastic and rubber warranty is 1 year.

Model: CLP2 **Price:** \$595



LIFTING CHAIN

Lifting Chains give variable resistance to standard core movements. At the beginning of a movement most of the chain is not engaged (resting on the floor). As the exercise is performed the chain is then "lifted" and adds resistance during the movement. Chain can maximize resistance at the end of a rep to match the body's strength curve. Each link provides more resistance as it lifts off the floor. Each chain is 60-inches long and features a chrome-plated bar collar for adding to weight lifting bars. Sold in pairs. WT620 set is built from 1/2" diameter chain and weighs 22 lbs. (Each chain weighs 11 lbs.). WT630 set is built from 3/8" diameter chain and weighs 30 lbs. (Each chain weighs 15 lbs.). WT640 set is built from 3/4" diameter chain and weighs 52lbs. (Each chain weighs 26 lbs.)

Model: WT620 (Light - Pair) **Price:** \$149
Model: WT630 (Medium - Pair) **Price:** \$188
Model: WT640 (Heavy - Pair) **Price:** \$237



CHALK

100 percent pure magnesium carbonate to keep hands dry for a secure grip. 1 lb. box contains 8 - 2 oz. blocks.

Model: WE3057
Price: \$15



PRO CHALK CONTAINER

Model: 68130
Price: \$169



COTTON LIFTING STRAPS

Strong 1 1/2" cotton webbing, double-stitched for durability. White. 1 lb.

Model: WE316
Price: \$11/pair



LEATHER LIFTING BELTS

Top quality 1/4" thick cowhide Lifting Belts. Double-prong seamless roller buckle. 4" width.

Model: WE320S 24"-30" **Price:** \$54
Model: WE320M 31"-37" **Price:** \$54
Model: WE320L 38"-44" **Price:** \$54
Model: WE320XL 45"-51" **Price:** \$54



CAST IRON PLATES (SOLD IN PAIRS ONLY)

The YORK Standard Olympic Plates are the meat & potatoes of the iron game. These simple sturdy plates are economical and well built and do not need many bells & whistles to get by—just solid muscle building power. Color is black. Sold in pairs only.

Model: 7350 - 2.5 lb. **Price:** \$5 per pair
Model: 7351 - 5 lb. **Price:** \$9 per pair
Model: 7352 - 10 lb. **Price:** \$19 per pair
Model: 7353 - 25 lb. **Price:** \$45 per pair
Model: 7354 - 35 lb. **Price:** \$63 per pair
Model: 7355 - 45 lb. **Price:** \$79 per pair



Order 24/7 at www.raecrowther.com

YORK BLACK BUMPER PLATES

These bumper plates are an excellent choice for the strength program that is looking for a quality bumper with great performance at an economical price. These bumpers have a solid rubber construction and a reinforced 2-inch center steel sleeve. They come with a full 1 year warranty. The color is black. Sold in pairs only.

Model: 29067 - 10 lb. **Price:** \$31 Order 3 or more pairs, save 15% (\$26)
Model: 29069 - 25 lb. **Price:** \$77 Order 3 or more pairs, save 15% (\$65)
Model: 29070 - 35 lb. **Price:** \$108 Order 3 or more pairs, save 15% (\$92)
Model: 29071 - 45 lb. **Price:** \$139 Order 3 or more pairs, save 15% (\$118)

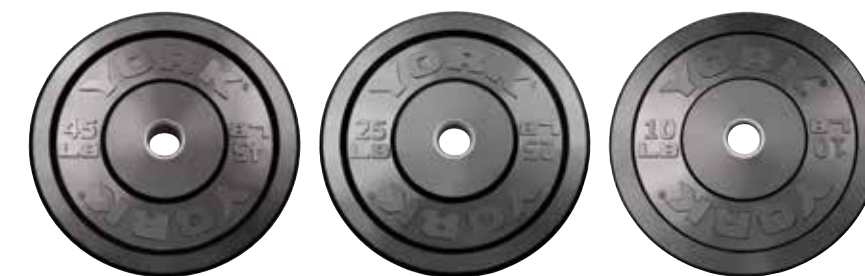

ELITE BUMPER WITH OPTIONAL CUSTOM LOGOS

These Elite Bumpers are manufactured from high quality virgin rubber and a zinc-coated stainless-steel center plate. The plate Diameter is 17.72 inches (IWF Standard), Collar Diameter is 50.4mm/1.98 inches, rubber durometer range is 88-92. The 50.4 mm collar opening is able to fit any standard Olympic barbell. These plates are thin-cut to enable a higher loading capacity and are best suited for Olympic lifting and will have a consistent dead blow with minimal bounce. The 10 lb. plate is a special "Phantom" plate that works like a technique training bumper. It will not crack like a typical 10 lb. bumper and can be used alone on the bar. What makes them even more amazing is we can add your custom school logo at a fraction of traditional logo pricing, and we typically can deliver the bumpers within 4 weeks. Any custom logo job requires a minimal order of 8 plates (same poundage). There is a \$150 set up charge per plate group (45, 35, 25 etc.) and only a cost of \$6 per plate to print. Warranty is 3 years on the plates, 10 lb. Phantom plate has 2 year warranty, logo warranty is 90 days. Warranties only apply to manufacturing defects and not to normal wear and tear. Customer must provide camera-ready artwork. Artwork that needs work or massaging by our graphic artist in order to bring up to printing resolution is charged at \$90 per hour.

Sold in pairs (see text above to calculate logo price or call us)

Model: EBP10 10 lb "Phantom" **Price:** \$133 per pair
Model: EBP25 25 lb Elite **Price:** \$237 per pair
Model: EBP35 35 lb Elite **Price:** \$297 per pair
Model: EBP45 45 lb Elite **Price:** \$372 per pair
Model: EBP55 55 lb Elite **Price:** \$399 per pair



PRO BUMPER PLATE RACK (HANDLE AND WHEELS)

This is a horizontal bumper plate rack. The spacing of the slots is as follows: Two slots spaced 6" apart, two slots spaced 4 1/2" apart, two slots spaced 2 1/2" apart. Additionally the rack includes a small weight horn welded to the frame for 2.5 lb. plates. Standard color is matte crinkle black.

Model: 5155 **Price:** \$249 Order 4 or more and save 15% (\$211)

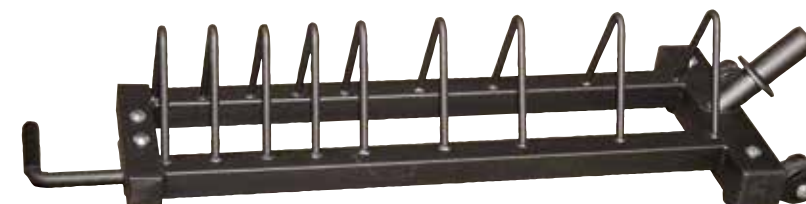

FAX: 803-366-3633

HORIZONTAL PLATE RACKS

Made to fit "Elite" Competition Bumper Plates, "Solid Rubber" Bumpers, and desired increments of Olympic Plates. Half Set configuration: "Elite" Competition Plates: 1 x 25, 20, 15, 10, and 5 kgs OR "Solid Rubber" Training Bumpers: 1 x 25, 20, 15, and 10 kgs OR Olympic Iron Training Plates: 2 x 1.25, 2.5, and 5 kgs. Full Set configuration of Bumper Plates doubles the Half Set configuration. The quantity of Olympic Iron Training Plates remains the same. Color: Black. Weights Sold Separately

Model: 69040 Half Rack **Price:** \$175 | **Model:** 69041 Full Rack **Price:** \$189



Call Toll-Free: 800-841-5050

YORK RUBBER HEX DUMBBELLS

These dumbbells feature contoured, knurled chrome handles and durable rubber-covered heads, which are permanently affixed to a 35 mm solid steel shaft for strength. Smaller handles graduate up from 25 mm grip to 35 mm grip for increments 20 lbs through 125 lbs. The rubber coating increases durability, protects flooring and equipment, enhances appearance, diminishes noise and is easy to clean. 1 Year warranty.

- Model:** SD1Y 5-50 Set (in 5 lb. increments - 10 pairs) **Price:** \$695
- Model:** SD2Y 55-100 Set (in 5 lb. increments - 10 pairs) **Price:** \$1995
- Model:** SD3Y 5-75 Set (in 5 lb. increments - 15 pairs) **Price:** \$1595
- Model:** SD4Y 105-125 Set (in 5 lb. increments - 5 pairs) **Price:** \$1445



2 TIER HEX DUMBBELL RACK

Among the most versatile of dumbbell storage racks, the 2-tier Tray Dumbbell Racks can accommodate a number of different styles of dumbbells. The 16" deep formed steel trays are rubber lined and ergonomically angled for ease of use. Dimensions: (L) 99"x (D)23"x (H)27" x 296 lbs. Powder coated black. Dumbbells sold separately.

Model: 69128Y **Price:** \$635



3 TIER HEX DUMBBELL RACK

Among the most versatile of dumbbell storage racks, the 3-tier Tray Dumbbell Rack can accommodate a number of different styles of dumbbells. The 16" deep formed steel trays are rubber lined and ergonomically angled for ease of use. Dimensions: (L) 99"x (D)23"x (H)27" x 325 lbs. Powder coated black. Dumbbells sold separately.

Model: 69129Y **Price:** \$885

YORK HERCULES KETTLEBELLS

The YORK Hercules Kettlebells will appeal to experts and beginners alike. The product sports a rugged matte black finish and has a uniquely positioned handle for a smooth, ergonomic motion. These kettlebells are perfect for a variety of Crossfit movements including the Russian Swing, One-Armed Clean, and the Two-Armed Push Press, as well as acting as a weight aid for squats and lunges. Warranty 1 year.



- Model:** KB5Y **Price:** \$8 Order 3+, save 10% (\$7)
- Model:** KB10Y **Price:** \$15 Order 3+, save 10% (\$13)
- Model:** KB15Y **Price:** \$21 Order 3+, save 10% (\$19)
- Model:** KB20Y **Price:** \$29 Order 3+, save 10% (\$26)
- Model:** KB25Y **Price:** \$36 Order 3+, save 10% (\$32)
- Model:** KB30Y **Price:** \$43 Order 3+, save 10% (\$39)
- Model:** KB35Y **Price:** \$50 Order 3+, save 10% (\$45)
- Model:** KB40Y **Price:** \$57 Order 3+, save 10% (\$51)
- Model:** KB45Y **Price:** \$64 Order 3+, save 10% (\$57)
- Model:** KB50Y **Price:** \$71 Order 3+, save 10% (\$64)
- Model:** KB60Y **Price:** \$85 Order 3+, save 10% (\$76)
- Model:** KB70Y **Price:** \$99 Order 3+, save 10% (\$89)
- Model:** KB80Y **Price:** \$114 Order 3+, save 10% (\$103)

THREE TIER KETTLEBELL STAND

This stand can hold a 5-80 kettlebell set. The shelves are rubber lined, and constructed from 2" x 2" x 11 gauge steel tubing. Powder coated in a metallic silver finish. 45" w x 24" depth x 33" v. Weight 77 lbs.

Model: 15100 **Price:** \$259



Order 24/7 at www.raecrowther.com

VINYL SPEED ROPE

These vinyl speed ropes with plastic handles are the ideal rope for most athletic programs. They are very economical and durable. Choose from 8' to 10' in length. Colors vary by size.

- Model:** SPR8 8' **Price:** \$3
- Model:** SPR9 9' **Price:** \$4
- Model:** SPR10 10' **Price:** \$5



SPEED ROPE

The speed rope has stainless steel cables encased in plastic for maximum speed. Uses ball bearings in handles. Comes with carry bag.

- Model:** TA128 - 9' Speed Rope **Price:** \$17
- Order 5 or more and save 10%. **Price:** \$15
- Model:** TA1281 - 10' Speed Rope **Price:** \$19
- Order 5 or more and save 10%. **Price:** \$17



FOAM BALANCE PAD

Balance pads have destabilizing properties, allowing you to add a challenge to push-ups, squats, lunges, and 1- and 2-legged balance movements. Constructed from molded closed-cell EVA foam provides durability and protection against odor-causing moisture. Do not stand on while wearing shoes. Blue. 17" L x 10" W x 2 3/8" H. 2 lb

Model: TA1803 **Price:** \$29



BALANCE DISC CUSHION

Build strength by using this air-filled disc when doing balance-based exercises. Soft PVC. Sold individually. Colors: specify blue, red, or purple.

Model: TA365 **Price:** \$29



FOAM ROLLER PAD

Use the full round roller for advanced balance exercises. Full round rollers can also be used for pressure massage. Roll across the target area to relieve muscle soreness and tightness. Constructed of high-density foam. 6" round x 3' long.

Model: TA3620 **Price:** \$39



FITNESS RINGS

Fitness rings are simple, portable tools with a variety of uses. Formed in durable thermoplastic with forged aluminum hardware, these rings can be hung and used just about anywhere. Each package contains two rings, two straps w/buckles, and a convenient carrying bag. Sold as a pair.

Model: TA1598 **Price:** \$95

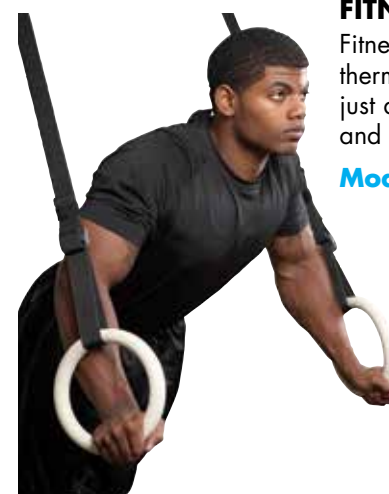

10 & 20 LB. WEIGHTED VESTS

These vests have a unique stretchable neoprene strapping system that secures the vest to the athlete's body while allowing the vest to expand and accommodate normal breathing patterns during exercise. Vest holds double stitched 1/2 lb. shot filled weight packets.

- Model:** TA1226 10 lb. Short Vest **Price:** \$99
- Model:** TA1227 20 lb. Long Vest **Price:** \$159



Short Vest





REGULAR MED BALLS

Perfectly balanced and durably constructed, our Med Balls are guaranteed to maintain their shape. Perform traditional medicine ball exercises or pass them to a partner or rebounder. The textured surface of these medicine balls ensures superior grip and handling. Incorporate them into any group fitness, sport-specific, or rehabilitation movement for added resistance. Hollow synthetic rubber construction allows medicine balls to bounce.

Model: GMB4	4 lb.	Price: \$26	Order 3 or more, save 10% [\$23]
Model: GMB6	6 lb.	Price: \$28	Order 3 or more, save 10% [\$25]
Model: GMB8	8 lb.	Price: \$32	Order 3 or more, save 10% [\$29]
Model: GMB10	10 lb.	Price: \$35	Order 3 or more, save 10% [\$31]
Model: GMB12	12 lb.	Price: \$39	Order 3 or more, save 10% [\$35]
Model: GMB15	15 lb.	Price: \$48	Order 3 or more, save 10% [\$43]

WALL BALLS

Wall Balls are large diameter foam medicine balls. Each Wall Ball is 14" in diameter. Made of durable synthetic leather and designed for superior grip, each ball is stitched to our exacting specifications and comes with a 1 year commercial warranty. Wall Balls are perfect for any athletic applications. Each Wall Ball comes with a 1 year warranty against breakage. Please note, our Wall Balls are tough but they're not slam balls. Slamming the Wall Ball will void the warranty.



Model: PWB-004	4 lb.	Price: \$44	Order 3 or more, save 10% [\$40]
Model: PWB-006	6 lb.	Price: \$47	Order 3 or more, save 10% [\$42]
Model: PWB-008	8 lb.	Price: \$50	Order 3 or more, save 10% [\$45]
Model: PWB-010	10 lb.	Price: \$53	Order 3 or more, save 10% [\$48]
Model: PWB-012	12 lb.	Price: \$56	Order 3 or more, save 10% [\$50]
Model: PWB-014	14 lb.	Price: \$59	Order 3 or more, save 10% [\$53]
Model: PWB-016	16 lb.	Price: \$63	Order 3 or more, save 10% [\$57]
Model: PWB-018	18 lb.	Price: \$68	Order 3 or more, save 10% [\$61]
Model: PWB-020	20 lb.	Price: \$72	Order 3 or more, save 10% [\$65]



SLAM BALLS

The 9" diameter Slam Ball is a rubber ball filled with iron shot that can be slammed to the ground violently from an overhead position. The slam ball is used for total body conditioning as well as building explosive strength in the torso and legs. These Slam balls do not use a cork stopper. Slam away! 90 day warranty.

Model: VUL10	10 lb.	Price: \$19	Order 3 or more, save 10% [\$17]
Model: VUL15	15 lb.	Price: \$25	Order 3 or more, save 10% [\$22]
Model: VUL20	20 lb.	Price: \$32	Order 3 or more, save 10% [\$29]
Model: VUL25	25 lb.	Price: \$39	Order 3 or more, save 10% [\$35]
Model: VUL30	30 lb.	Price: \$45	Order 3 or more, save 10% [\$40]
Model: VUL35	35 lb.	Price: \$49	Order 3 or more, save 10% [\$44]
Model: VUL40	40 lb.	Price: \$59	Order 3 or more, save 10% [\$53]
Model: VUL50	50 lb.	Price: \$60	Order 3 or more, save 10% [\$54]

STABILITY BALLS

Excellent for balance, abdominal work and stretching. Each ball is fabricated from the finest vinyl designed to support 500 lbs. of weight. Ball size used according to athlete's height. Shipped deflated.

Model: TA1805	55cm (5'-5'8")	Price: \$26
Model: TA1806	65cm (5'8"-6'2")	Price: \$29
Model: TA1807	75cm (6'2"+)	Price: \$32



MED BALL RACKS (above)

Sturdy and durable vertical storage for your medicine balls. Painted Black. 1 Year Warranty.

Model: (Single) TA129	Price: \$115
Model: (Double) TA1292	Price: \$159

MED BALL CAGE (below)

48"L x 24"W x 36"H. Painted Black. 55 lbs. 1 Year Warranty.

Model: PM93930	Price: \$235
-----------------------	---------------------



TRAINING ROPE

50' length x 1.5" diameter x 24 lbs. Training Ropes are a great choice indoor or out. A braided Training Rope does not shed and is non-abrasive. Ropes offer you a complete, full-body workout. The braided ropes are 80% danline and 20% polyester – they are more durable and have a greater life span than manila ropes and feature a plastic boot on each end to prevent fraying. You will quickly notice how training will transfer into your sport or activity. You will not only have a lot of fun with your training, but you will also find yourself more motivated in general. This is due to the increased physical and mental discipline you will gain.

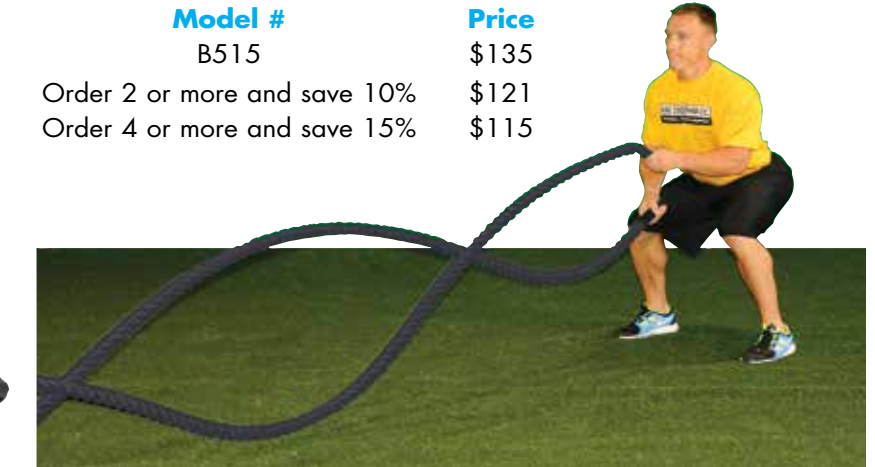

Model #	Price
B515	\$135
Order 2 or more and save 10%	\$121
Order 4 or more and save 15%	\$115

PROFESSIONAL TUBING

Versatile devices for a variety of strength and fitness exercises. Adjustable from a maximum of 4' down to desired length. Color coded tubing for desired resistance. Includes two rotator handles and door attachment.

Model: Xtra Light	TA1735	Light Blue	Price: \$10
Model: Light	TA1736	Magenta	Price: \$11
Model: Medium	TA1737	Orange	Price: \$12
Model: Heavy	TA1738	Red	Price: \$12
Model: Xtra Heavy	TA1739	Yellow	Price: \$17



STRENGTH BANDS

Strength Bands are a cost-effective exercise tool. Available in 6 resistance levels. They are adaptable for multiple ages and fitness levels. A one stop shop in helping athletes. You can adjust the amount of resistance during exercise by adding pre-tension, standing closer or farther away, or combining bands together. Strength Bands can be used for any exercise and for every muscle group.

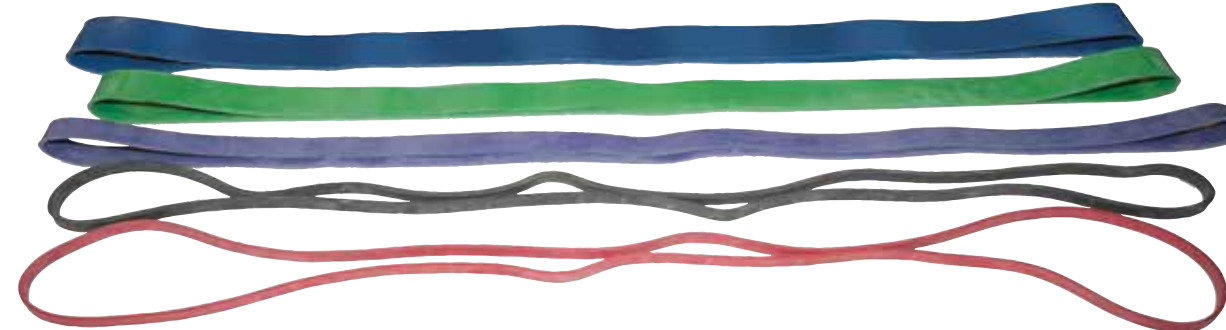

Model: J1	#1 Mini	5-35 lb.	Red	13 mm wide	Price: \$12	Order 5 or more and save 15% [\$10]
Model: J2	#2 Super Mini	10-50 lb.	Black	20 mm wide	Price: \$16	Order 5 or more and save 15% [\$14]
Model: J3	#3 Small	25-80 lb.	Navy	29 mm wide	Price: \$21	Order 5 or more and save 15% [\$18]
Model: J4	#4 Medium	50-120 lb.	Green	45 mm wide	Price: \$28	Order 5 or more and save 15% [\$24]
Model: J5	#5 Large	60-150 lb.	Royal	64 mm wide	Price: \$33	Order 5 or more and save 15% [\$28]



JUMP SMART PLYOS

Use our Jump Smarts to raise explosive power, increase ground reaction force, and enhance muscle stiffness (tension). The Rae Crowther Jump Smart Plyos are the best value in the industry. Quality construction, durability, and functional design. As one of the leaders in the industry we started making the foam jump box over 12 years ago! Jump Smart Plyos are high-density foam 32" diameter plyometric discs. The heaviest Foam Plyos in the industry. High density foam with inserted rubber encased in heavy nylon vinyl with zippers and handles. Each individual disc (3", 6", 12", 18", 24", or 30") velcros securely to each other. An improvement in safety over traditional steel boxes. High-density plyo boxes. Please see our extensive list of exercises with the Jump Smarts on YouTube. Color: Black.

"The guys love it! They are always aware of the edges on traditional Plyo Boxes, but with these, they have nothing to worry about. When the guys have a choice between the traditional Plyo box and the Rae Crowther Jump Smart foam plyo box, they choose the Jump Smart every time!"



Rock Gullickson Strength and Conditioning St. Louis Rams



Height	Diameter	Weight	Model	Price
3"	32"	25 lb.	JSP3	\$119
		Order 2 or more and save 10%		\$107
		Order 4 or more and save 15%		\$101
6"	32"	36 lb.	JSP6	\$139
		Order 2 or more and save 10%		\$125
		Order 4 or more and save 15%		\$118
12"	32"	65 lb.	JS.P12	\$199
		Order 2 or more and save 10%		\$179
		Order 4 or more and save 15%		\$169
18"	32"	91 lb.	JSP18	\$259
		Order 2 or more and save 10%		\$233
		Order 4 or more and save 15%		\$220
24"	32"	115 lb.	JSP24	\$319
		Order 2 or more and save 10%		\$287
		Order 4 or more and save 15%		\$271
30"	32"	145 lb.	JSP30	\$379
		Order 2 or more and save 10%		\$341
		Order 4 or more and save 15%		\$322

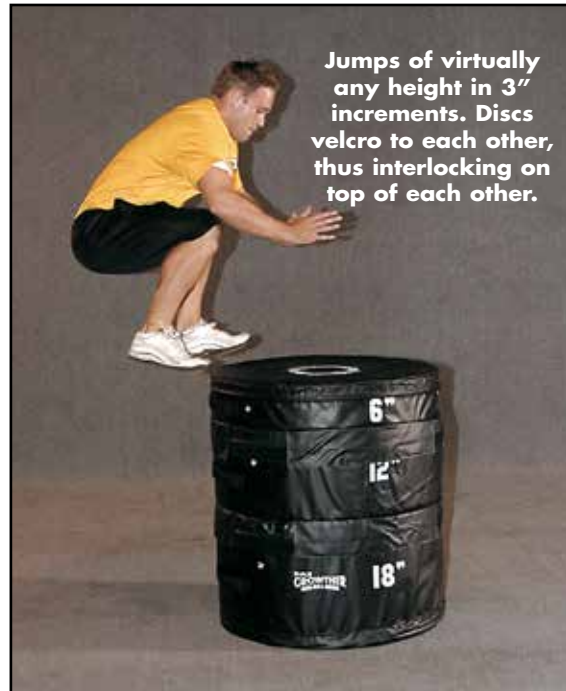

Jumps of virtually any height in 3" increments. Discs velcro to each other, thus interlocking on top of each other.

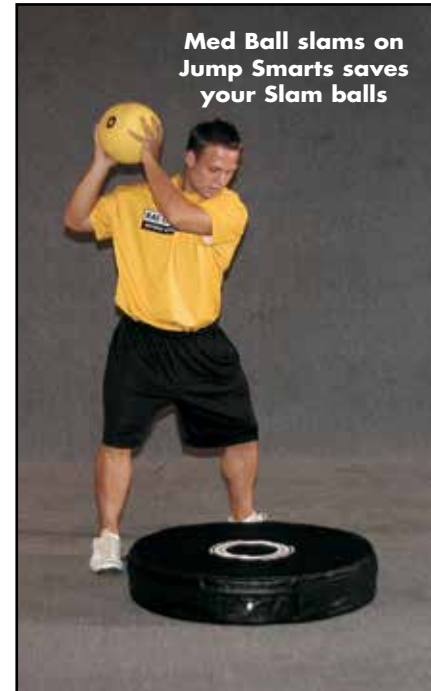

Med Ball slams on Jump Smarts saves your Slam balls

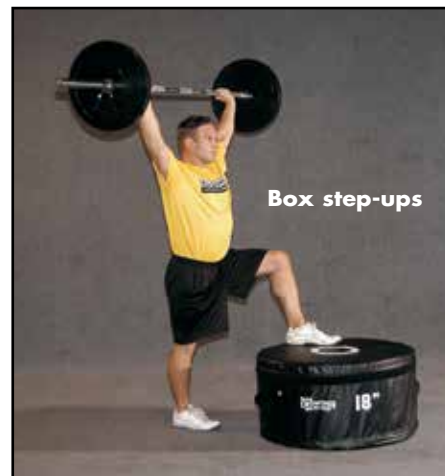

Box step-ups



No hard edges to hurt your athletes!

METAL PLYO BOXES



Jumping on and off boxes is one of the best plyometric exercises to improve leg power, speed, and strength. Each box is constructed of 1" square steel tubing. The top platform is covered with 10 mm thick rubber track surface. Anti-skid rubber is located at base corners to prevent slipping and to protect floors. Tapered design allows for much greater stability and easy stacking for storage.

Starter Set: (12", 18", 24", 30")
Model: TA301 Price: \$459

Advanced Set: (12", 18", 24", 30", 36", 42")
Model: TA300 Price: \$749

Model: TA306	6" Box	Price: \$99
Model: TA312	12" Box	Price: \$119
Model: TA318	18" Box	Price: \$125
Model: TA324	24" Box	Price: \$139
Model: TA330	30" Box	Price: \$149
Model: TA360	36" Box	Price: \$169
Model: TA342	42" Box	Price: \$179

3 IN 1 WOOD PLYO BOX

The 3-in-1 Wooden Plyo Boxes feature three height options and an innovative design. These Plyo boxes are hand made, glued and screwed with rounded and sanded edges to prevent injury. The boxes are coated with a polyurethane finish to reduce wear and tear and to keep the box looking good. Uncoated boxes tend to get dirty and detract from the look of the weight room. Two Box sizes are available; W20 is 16", 18", 20" and W30 is 20", 24", 30" to allow you to customize your workout and adjust on the fly.

Model: PLYO-W20 (16", 18", 20") Price: \$159
Model: PLYO-W30 (20", 24", 30") Price: \$179



METAL AGILITY LADDER

Foot fire! The Metal Agility Ladder is similar to the traditional foot ladder but is made from metal so that it will not kick out of place. The Metal Agility ladder is light enough to transport but heavy enough to stay in place. The Ladder measures 19' long (you can add to that length if you desire with individual sections). Comes in 4 sections that slide together for easy shipping, travel, and set up. The metal squares are 1/2" tall, so it can be used with sneakers or cleats. Use the ladder in a straight agility pattern or make 90 degree intersections. For multiple drills see our video on YouTube under the Rae Crowther channel. Can be used for lower and upper and body training (such as pushups). Use with slam balls and other implements to raise the challenge. Keep the ladder inside or outside. Order in quantity and save. Each section is 4.75 feet long (57). Each foot hole is 19" x 19". Powder coated yellow. Weight: 24 lbs. per ladder.

Model: GPR1 Price: \$199

Order 2 Ladders and save 10%. Price: \$179

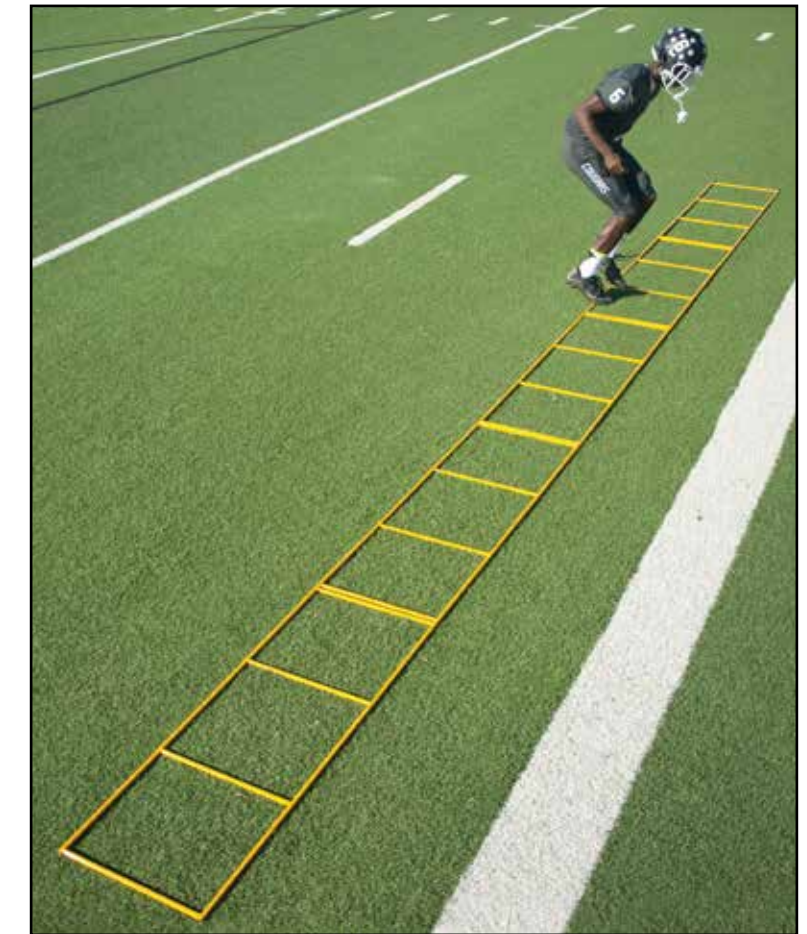

15' DOUBLE AGILITY LADDER

The Double Agility Ladder is 15' long and 36" wide. Ten rungs have webbing down the center and each side. The rungs are flat for improved safety. Slats are not adjustable and won't crack when stepped on. Has storage case with carry handle.

Model: TA1682 **Price:** \$119

Order 2 or more **Price:** \$107 and save 10%



HURDLE

This economical hurdle meets official pull over resistance at all high school heights. Trigger release system allows for pain-free height adjustment to 5 heights: 30", 33", 36", 39", and 42". Rigid double-crossbar design ensures superior durability. All steel construction, powder coated tubes, and PVC gate board. Silk screen not available. Black gate tubes only. Ships partially assembled. Meets high school specifications. 1 Year warranty.

Model: 400 **Price:** \$105

Order 2 or more **Price:** \$94 and save 10%



DOT DRILL MAT

Improve foot speed, reaction time, and balance. Perform multiple footwork patterns. Start with both feet and progress to single foot drills. Position multiple mats in a row to increase the challenge. Molded on dots, not painted. 25 lb.

Model: TA1425 **Price:** \$99

Order 2 or more **Price:** \$89 and save 10%



30' AGILITY LADDER

Transcend to new quickness. Coaches love speed, so we either have to recruit it or teach it. The original ladder used by top athletes and teams worldwide to improve footwork. Easy to transport and store, this practice tool can be used daily in season and out of season. Four 7' 6" sections make it easy to adapt to sport specific footwork drills. 30' total length, slats won't crack when stepped on. Has storage case with carry handle.

Model: TA1681 **Price:** \$79

Order 2 or more **Price:** \$71

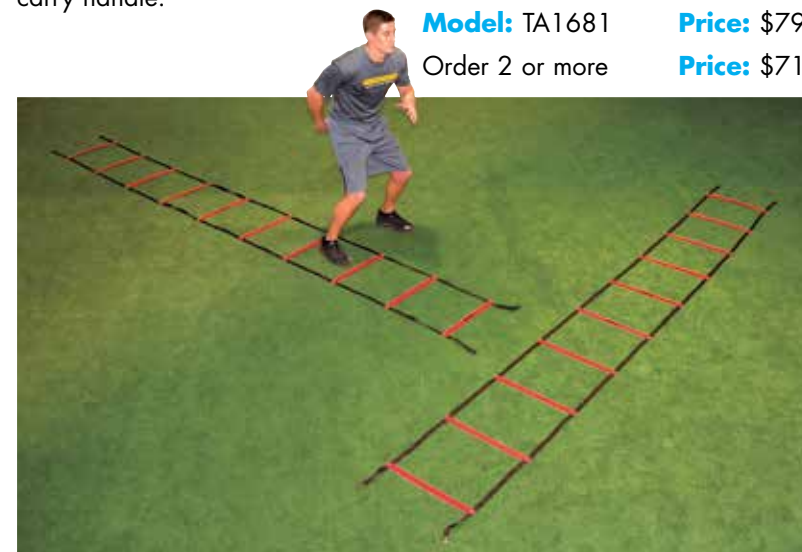

STEP-HURDLES

Improves knee lift and step quickness. Position hurdles for agility drills, running drills and plyometric jumps. Use with forward and lateral drills. Constructed of durable PVC tubing. Four different height hurdles are available; each hurdle has an 18" width.

Model: TA1675 6" **Price:** \$11

Model: TA1665 12" **Price:** \$12

Model: TA16618 18" **Price:** \$19

Model: TA16624 24" **Price:** \$21



Order 24/7 at www.raecrowther.com



RESISTANCE TETHER (INCLUDES WAIST BELT AND A HANDLE)

Develop maximum strength and power for running and change of direction. The Resistance Tether keeps resistance around the hips and torso of the athlete. The harness attaches to a 10' long nylon web cord with a handle. The Resistance Tether includes a nylon web cord and a 3" wide hook & loop closure belt adjustable to a 42" waist. Includes a carry bag and instructions. The Resistance Tether also accommodates an optional shoulder harness for an upper body workout and is Max Belt compatible.

Model: TA150 **Price:** \$49 (Order 2 or more and save 10%: **Price:** \$44)

DYNAMIC TRAINER

A great training tool that provides resistance and assistance. 10' elastic tube is covered with nylon webbing and can stretch up to 30'. Max Belt compatible. 1 Year Warranty.

Model: TA158 **Price:** \$159

(Order 2 or more and save 10%) **Price:** \$143



TC SPEED TRAP I (See photos below)

This system times distance up to 55 yards and is accurate to the hundredth of a second. Timing starts upon release of foot pad pressure and is stopped when infrared finish line beam is tripped. Includes Speed Trap I timer, start pad, 55 yards of wire, sensor, stopwatch, tripod, carrying case, and instructions.

Model: E38710 **Price:** \$795

TC SPEED TRAP II (See photos below)

The TC-Speed Trap II is the latest development in timing systems. The TC-Speed Trap II is a wireless timing device that enables athletes and coaches to measure time, speed, count repetitions, input test data and save it all in the TC-Timer memory. The TC-System can send radio transmissions up to 1,000 feet and is accurate to the thousandth of a second, making it a highly precise timing tool. It is also equipped with five different radio frequencies allowing multiple systems to be used in the same area. All components fit neatly into a small lumbar pack.

Model: E38720 **Price:** \$1895

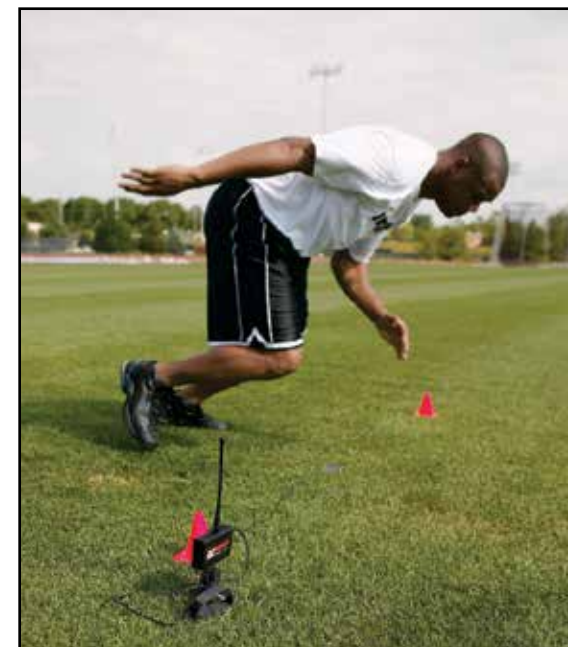

FAX: 803-366-3633

Call Toll-Free: 800-841-5050

DRAGON SLAYER™ CONDITIONING SLED

The Dragon Slayer can challenge even the best conditioned athletes. This multi-purpose sled can be used to push or pull. 6 multiple gripping areas allow a variety of angles. 34" height to top of bar.

When used with an agility cone course, the drills become unlimited. For instance, fast run with the sled, slalom, punch and run, use 1 or 2 handed, 1 leg or 2, uphill or downhill. Made with 2" heavy duty tubing.

16" wide "thumbs-up" grip. With the Dragon Slayer, players are placed in a strong athletic position. Use the sled competitively. Two plate holders per sled. Optional Carpet Runner allows you to train on a wood floor any time of the year.

Push with or w/o added weight, fast, medium, or heavy. Use with all players. Welding rings on the back of the pontoons allow easy harnessing. Weighs 50 lbs. Powder coated white.

Model: DRS1 Dragon Slayer Sled **Price:** \$395
Model: TA15401 Waist Harness **Price:** \$39
Model: DRS6 Indoor Carpet Runner **Price:** \$124



**Order 2 or more
DRS1 and save
15% (\$336)**

POWER SLED WITH OPTIONS

Includes sled, 11' leads, 3" wide hook & loop closure belt adjustable to 42" waist, and instructions. The Sled also accommodates an optional shoulder harness for an upper body workout and is Max Belt compatible.

Few athletes ever reach their true potential in speed. Speed takes considerable time to develop because of the fine motor skills required to achieve maximum performance. Use the Power Sled for systematic training. Provides lower body resistance that develops speed and strength. Work forward lunges, backward walks, bear crawls, squat rows, chest presses. Add the desired weight to determine resistance. Load up to 200 lbs.

Model: TA154 Sled, Waist Harness, & Leads **Price:** \$165
Model: TA15401 Additional Waist Harness **Price:** \$39
Model: TA15402 Additional Pair of Leads **Price:** \$28
Model: TA1500 Max Belt Small / Medium **Price:** \$33
Model: TA1501 Max Belt Medium / Large **Price:** \$35
Model: TA1503 Max Belt Large / Extra Large **Price:** 37
Model: TA164T Elastic Cord - Medium (20') **Price:** \$119
Model: TA165T Elastic Cord - Heavy (20') **Price:** \$129



**Order 2 or more
TA154 and save
10% (\$148)**

Optional Max Belt



Optional Elastic Cords



Order 24/7 at www.raecrowther.com



Model: SST-STAR
Price: \$95

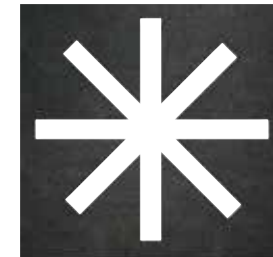

Model: SST-CROSS
Price: \$95

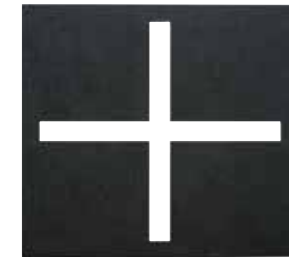

Model: SST-DOT
Price: \$95



SPORT TRAINING AGILITY STENCILS

Use these high quality stencils for creating Dot, Star, or Cross patterns on your floor. These high density thick plastic stencils are precisely water jetted out in the the pattern of a Star, Cross, or Dot pattern. Lay the stencil on the floor and paint inside the template with any kind of paint or spray paint. Use for setting up permanent patterns indoors or use for setting up quick patterns outside. The stencils can be reused as many times as you like. Buy the entire set or purchase any pattern individually. Please see video at RaeCrowther.com.

RUBBER MAT 4' X 6' X 3/4"

Economical and durable rubber mats can take the toughest weight room pounding. The easiest way to set up a home gym or protect a floor is with these rubber mats. Color is Black. Weight per Mat is Approx. 100 lbs. Each Mat is approx. 24 sqf. Some Mats may have a slight color difference. (Please note minimum quantity order for Mats is 10 pieces).

Special Deals: Unit price is \$45

Order	Save	Total Cost
25 or more	5%	\$43
50 or more	10%	\$40
100 or more	15%	\$38

Model: RM46 **Price:** \$45



ROLLED RUBBER FLOORING

Rolled Rubber Flooring is a must have for your weight room, fitness, and workout areas. Save your cement, plates, bars, and most importantly protect your athletes. Specifically designed to be the best flooring in safety and performance. Designed for its load carrying capacity, flexibility and strength. It is not slick when dusty. Rubber flooring provides unmatched performance for personal training. Creates a professional look. Easy maintenance. Requires the services of a professional installer. Available in plain black or speckled colors.



Model: RB100-3/8 4 x 50' Roll of 9.5 mm (3/8") Flooring in Black **Price:** \$475
Model: RB100-3/8 4 x 50' Roll of 9.5 mm (3/8") Flooring In 10% Speckled Color **Price:** \$595

RAE CROWTHER CO.

ATHLETIC TRAINING EQUIPMENT

ORDER FORM 2018
 PO BOX 12157 • ROCK HILL, SC 29731
 PHONE: 800-841-5050 • FAX: 803-366-3633

 Please print clearly. You are welcome to fax the order to 803-366-3633 or mail to the P.O. Box address above. Thank You!

DATE: _____ **YOUR SCHOOL / UNIVERSITY PURCHASE ORDER NUMBER:** _____

BILLING ADDRESS:	SHIPPING ADDRESS:	PHONE / FAX / E-MAIL:

SHIPPING: All items will ship via motor freight except those items that are UPS-able. Call for exact shipping amount.

CREDIT CARDS:     Please print your full name as it appears on the card. Please include your full billing address with expiration date and security code (security code is 3-digit number found on back of card.)

QTY:	MODEL #:	DESCRIPTION:	UNIT \$:	TOTAL \$:

Mission Statement: Our Mission at Rae Crowther is to create great looking equipment (big time wow factor!) that reduces or eliminates practice injuries while also increasing the skill or strength level of athletes. Rae Crowther equipment is designed and sold to players, coaches, equipment managers, and athletic directors with the ultimate goal of developing oneself to the maximum extent possible, always striving for perfection, so that we can contribute something of value to the world. If you lose your dreams, you lose your mind.

How to Order: Order online 24/7, or phone, fax, mail, or e-mail your order. Use whatever method is most convenient for you. Our ordering numbers are on the back of the catalog and on the bottom of most pages.

Payments: We accept checks, Visa, Mastercard, American Express, Discover Card, and signed Purchase Orders from school districts. We also accept wire transfers on international orders.

Pricing, Discounts, & Standard Terms: Our lowest price is printed in the catalog. Shipping charges are not included in the price of the equipment. Shipping charges range depending on the equipment ordered. There is no minimum order.

Quotes: We are glad to provide a guaranteed quote on any product in the catalog. Just call the factory and ask for a guaranteed quote. Quotes are good for 30 days. Freight rates are only guaranteed when the delivery address is the exact same as quoted.

Changes & Updates: Items delivered may vary from photographs. Rae Crowther Co. reserves the right to update items or make changes to items at any time. It is always our goal to deliver to your field the very best product with the latest features.

Shipping & Delivery: Sleds normally ship within 3 to 5 weeks. Unfortunately, sometimes the shipping dock does become backlogged and/or backordered. Call for availability. The weights listed in the catalog are not shipping weights. All equipment is shipped F.O.B. Rock Hill, South Carolina. Free shipping only applies to the lower 48 states. Rae Crowther reserves the right to restrict free shipping. Free shipping not available to dealers.

Lost or Damaged Freight: Rae Crowther products leave the factory in perfect condition. When your equipment is shipped, you are sent important shipping instructions. We try to use the fastest and most reliable freight carriers. Once the equipment leaves our factory, the shipment is out of our control. If equipment is delivered short or damaged, it is the responsibility of the delivering carrier to pay any claims. It's very important that the person signing for the delivery writes the words 'Short' or 'Damaged' directly on the delivering carrier's ticket. Make a copy of the ticket immediately. We will help you file any claims that are necessary against the freight company. When damages or shortages occur, we are at the mercy and speed of the freight company. Usually the process takes 90 days or more to be reimbursed by a freight carrier.

Concealed Damage: If a product is found to be damaged after being removed from its box, please notify Rae Crowther Co. and the delivering carrier immediately. Ask the carrier to fill out a concealed damage report. Usually this must be done within a week of the delivery.

Non-Warranty Return Policy: Before returning any equipment, call the factory first and describe the problem. We will be glad to try to help or make appropriate amends to solve the problem. We do not ship equipment for loan or a trial basis. If there is an early cancellation date for your order, we need to know that before accepting the order.

Warranty Return Policy: Please call to make sure the equipment in question is under warranty, and, if so, you will be given a return authorization number. If the piece of equipment is under warranty, you must ship the product pre-paid. Rae Crowther Co. will inspect the product upon arrival. If the product is defective, Rae Crowther Co. will fix or replace the item and ship it back to the customer at no charge.

Refusal of Shipment: Refused shipments will be charged a 15% restocking fee and the total shipping costs. If you are purchasing equipment through a booster club with non-school funds, please notify the school to accept the freight on behalf of your team.

Limited Warranty: Rae Crowther Co.'s sole obligation and the buyer's sole remedy is to repair or replace, at our option, any part that is found to be defective during the warranty period. Repair or replacement must be made only by Rae Crowther Co. Any product thought to be defective must be returned to Rae Crowther Co. for inspection at the buyer's sole expense. A Return Authorization Number must be obtained from Rae Crowther Co. before returning a product under a warranty claim. This warranty does not cover products damaged in shipment or any product damaged as a result of misuse, negligence, accident, improper assembly, ordinary wear and tear, vandalism, or by repairs, alterations, or use of replacement parts not manufactured or installed by Rae Crowther Co.

Disclaimers Of Warranties: Rae Crowther Co. makes no warranties, representations, or promises, either express or implied, as to the quality or performance of its products other than those set forth above, and Rae Crowther Co. expressly disclaims all implied warranties, including but not limited to the warranty of merchantability and warranty of fitness for a particular purpose. Rae Crowther neither assumes responsibility for nor authorizes any other person to assume for it any liability in connection with the sale of its products. In no event shall Rae Crowther Co. be liable for consequential damages, personal injury, or property damage.

General Warning: Rae Crowther Co. equipment is designed to protect the safety of the players. However, by the very nature of the sport, methods of practice and conditioning to play the sport, and equipment designed for the sport and such practice, it is possible that serious bodily injury, death, or property loss and damage could result. The User knowingly and voluntarily assumes all risk of serious injury, death, and property damage related to the use of Rae Crowther Co. products, including those that may result from the negligence of Rae Crowther Co., its employees and agents, the User or any other person or cause. Use of Rae Crowther Co. products shall constitute a release by the User of Rae Crowther Co. and its shareholders, officers, employees, and agents and their respective successors and assigns from all liability from injury, death, and property loss or damage that is in any way related to the use of Rae Crowther products, including any and all liability that may result from the negligence of Rae Crowther Co., including its employees and agents, the User or any other person or cause. Rae Crowther Co. assumes no liability for improper use, negligent assembly, unauthorized alteration or modification, lack of supervision, the physical condition or health of any User, or other condition affecting the User and use of any Rae Crowther Co. product. The sole responsibility of Rae Crowther Co. is governed by its limited warranty. Consult all written materials accompanying Rae Crowther Co. products prior to any use or assembly.

Rae Crowther reserves the right to make changes to this catalog at any time. Certain items featured in this catalog are protected by the patent and trademark laws of the United States. Copyright © Rae Crowther Co., Inc. 2018.



Trim to here to Fax.



RAE CROWTHER CO.
ATHLETIC TRAINING EQUIPMENT

SINCE 1932
DOMINATE WITH FUNDAMENTALS
800.841.5050

PRSR STD
US POSTAGE PAID
BEAVER DAM, WI
PERMIT NO. 577

Patriot Double Rack

Elite Athlete Rack

Sport Training Rack



www.raecrowther.com | 800-841-5050