

# COMPOSITE SHUTTERS

## Table of Contents

<b>Features</b>	
Shutter Styles . . . . .	2-3
Product Illustration . . . . .	4
<b>Options</b>	
Louver Options . . . . .	5
Tilt Options: Hide-a-Tilt™, Split Tilt, and Panel Overlap Styles . . . . .	6
Double Mouse Hole, Color Options, Hardware Options . . . . .	7
Composite: Panel Configurations: Standard, Arch and Angled Top Shutters. . . . .	8
Size Considerations: Composite: Minimum and Maximum Width By Panel Configuration: 2½" and 3½" Louvers . . . . .	9
Size Considerations: Composite: Minimum and Maximum Width By Panel Configuration: 4½" Louvers . . . . .	10
Size Considerations: Composite: Minimum and Maximum Height Width By Frame Type. . . . .	11
Frame Type Decision Tree. . . . .	12
Measuring For Standard Shutters . . . . .	13
Measuring Divider Rail Location, Divider Rail Requirements, Measuring T-Post Locations . . . . .	14
Proper Application of the Tilt-Out Z-Frame, Sill Cap Application . . . . .	15
<b>Specifications</b>	
Specifications: Composite Frame Product Detail . . . . .	16-17
Specifications: Deductions For Frame Allowances . . . . .	18
Specifications: Composite Frame Configurations, Installation Hardware . . . . .	19
<b>Specialty Styles</b>	
Café Shutters . . . . .	20
Sunburst Arches Without Frame . . . . .	21
Sunburst Arches With Frame . . . . .	22
How to Make a Template . . . . .	23
Sunburst Arch Installation Methods and Frameless Arch Installations Options . . . . .	24
Arch and Angle Top Panel Shutters: Measuring Leg Height and Divider Rail . . . . .	25
Arch and Angle Top Panel Shutters: Minimum/Maximum Height . . . . .	26
French Door Shutters: Features and Minimum/Maximum French Door Sizes . . . . .	26
French Door Shutters: Cut-Out Options . . . . .	27
French Door Shutters: Placement Of L-Frame and Recessed Back Plate . . . . .	28
Bypass Shutters: Features and Valance Options. . . . .	29
Bypass Shutters: Mounting Options . . . . .	30
Bypass Track System Configuration Options and Minimum/Maximum Width By Panel Configuration . . . . .	31
Bypass Track System: Stack Back Option and Custom Header. . . . .	32
<b>General Information</b>	
Definitions . . . . .	33
Warranty and Care Instructions . . . . .	34
<b>Pricing</b>	
Composite Shutters Pricing . . . . .	35

# Features

## Shutter Styles

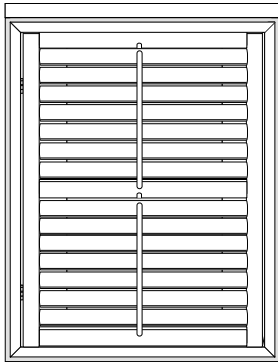

**Standard Panel:** A rectangular-shaped panel that can be installed using any frame style. Panel covers the entire window opening.

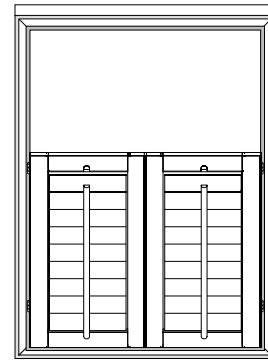

**Café:** Classic style covers the bottom part of the window, allowing light to enter while protecting your privacy. **Not recommended in composite; tops are not finished.**



**Bypass Track System:** Shutter panels slide on a top track to open and close. The track system can be attached to a frame or mounted directly to a window casing or the ceiling. Ideal for patios or closet doors. Louvers must be closed to pass.

**NOTE:** Shutters do not block all light from entering the room. All shutters have moving parts. These parts have tolerance gaps that will allow some light to filter through the shutter.

# Features

## Shutter Styles

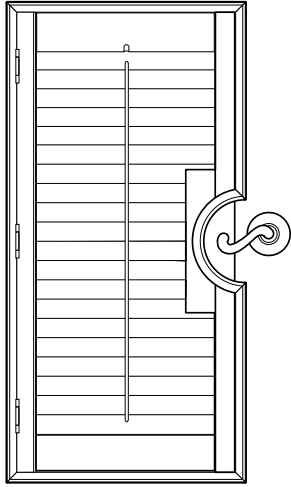

**French Doors:** Add the beauty of shutters to French Doors. Curved or rectangular cutout options complement contemporary door handles or traditional door knobs.

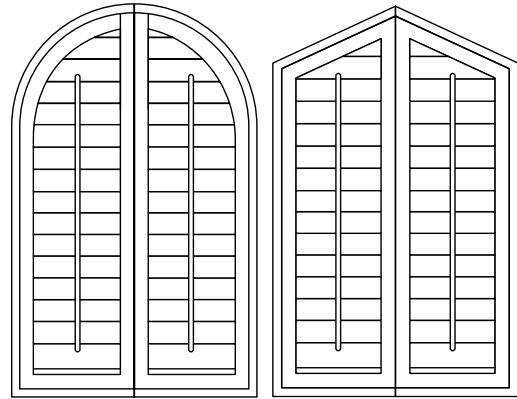

**Arch or Angle Top Panels:** Provide whole window solutions that fit the rounded shape of full arch windows perfectly. Angled panels accommodate slanted windows. Available in full arch or angle,  $\frac{1}{4}$  arch or  $\frac{1}{2}$  angle.

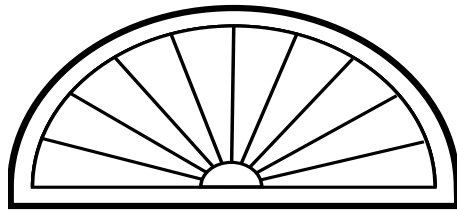

**Sunburst Arches:** Sunburst patterned louvers cover unique window silhouettes such as eyebrow, palladian, elongated and elliptical arches. Also available as  $\frac{1}{4}$  arches.

# Features

## Product Illustration

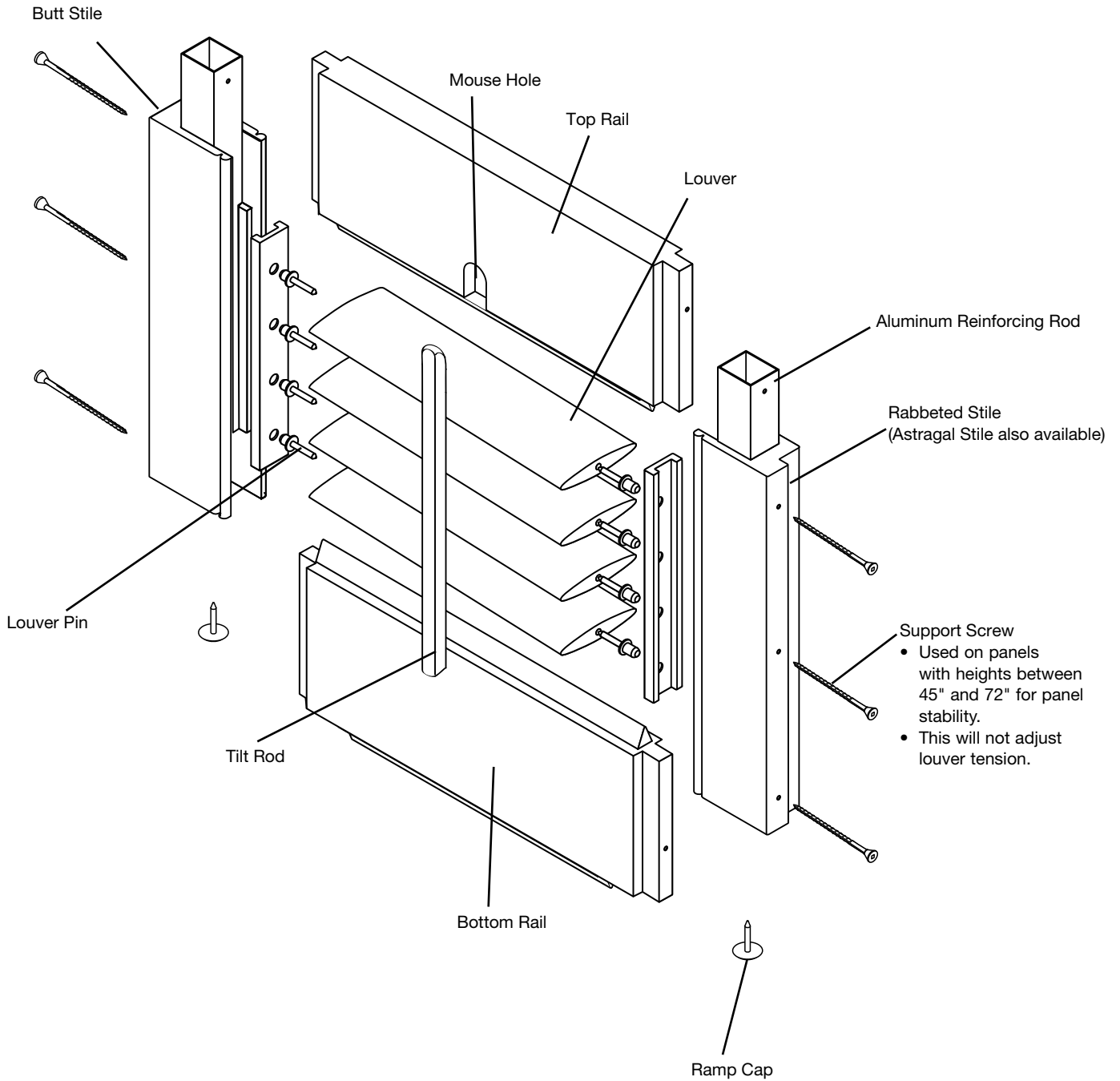

# Options

## Louver Options

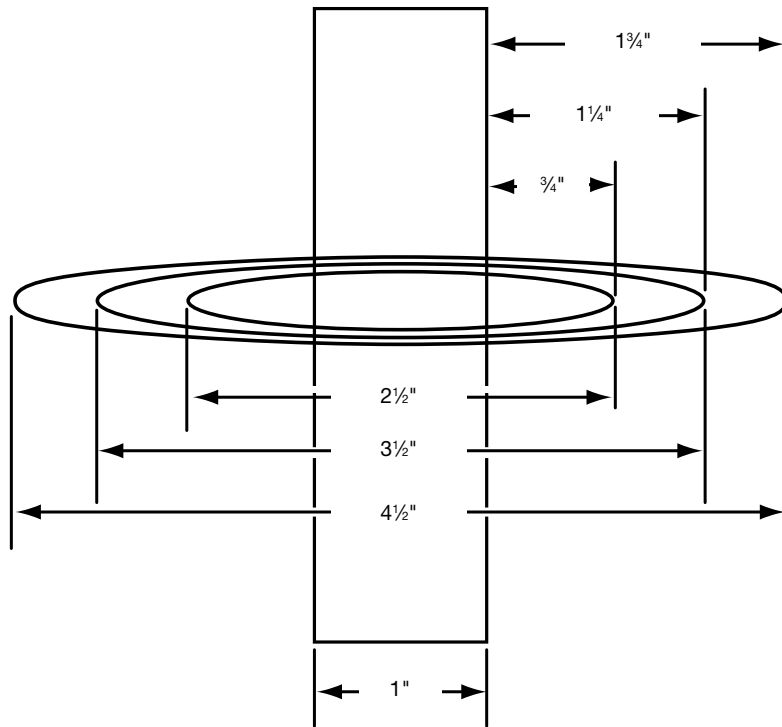

Minimum Clearance Needed From Back Panel Surface		
Louver Size (inches)	Standard Tilt (inches)	Hide-a-Tilt™ (inches)
2½	¾	1⅞
3½	1¼	1⅞
4½	1¼	2⅞

**NOTE:** Hide-a-Tilt™ requires an additional ⅜" window clearance.

### 2½" Louver

- Traditional in style
- Minimal window depth needed
- Shutters are focal point of the room

### 3½" Louver

- Most popular louver size
- Offers more visibility and light control

### 4½" Louver

- Provides the greatest visibility through the open louvers
- Looks most proportionate in a larger window, view beyond the window becomes more important
- Louvers almost disappear when open

### Composite Louver Sizes

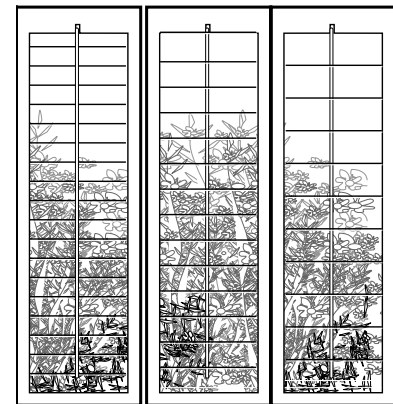

2½"

3½"

4½"

## Options

### Tilt Options: Hide-a-Tilt™

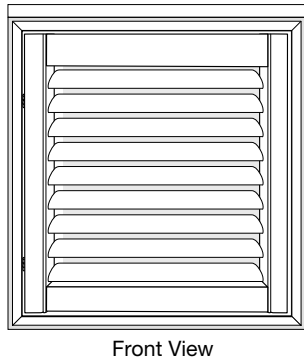
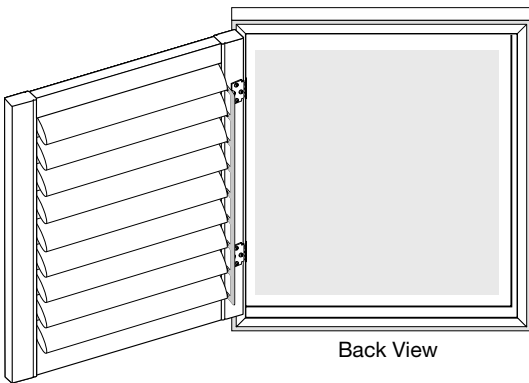

**Hide-a-Tilt Option** offers the tilt mechanism in the back of the shutter panel, eliminating the traditional tilt bar and creating an unobstructed view, as well as a clean linear appearance. A thin stainless steel tilt bar is attached to the louvers in the rear of the panel. Operation of the shutter is as simple as moving one louver into position; all of the other louvers will follow.

- Hide-a-Tilt bar will always be stainless steel color
- Hide-a-Tilt is mounted on hinge side for standard shutters
- No mouse hole in the panel
- Hide-a-Tilt allows the shutter to be closed in the upward or downward position

### Tilt Options: Split Tilt

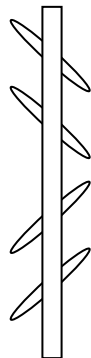
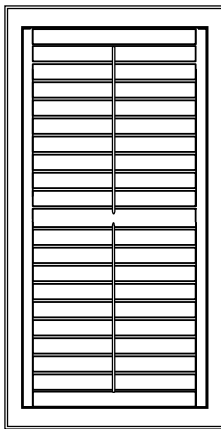

#### Split Tilt

No divider rail. Splits one large louver set into two individually operated louver sets by cutting the tilt bar.

- Split tilt is available for all louver sizes with Hide-a-Tilt™; it is not available on 2½" louver with standard tilt (the front tilt will not allow the louvers to function properly)
- 2½" and 3½" louvers—split will be specified as exact
- 4½" louvers—split may shift up or down +/- 2"

Consideration: Upper and lower louvers cannot be positioned at opposing angles because the edges of the louvers will touch.

**NOTE:** Top and bottom rails may vary or be unequal due to requested locations and louver spacing. Rail sizes vary from 3"-6".

### Panel Overlap Styles

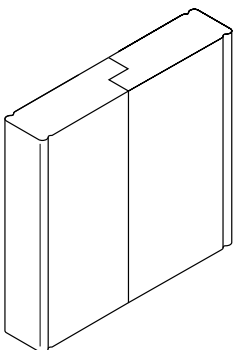

#### Rabbet Style Panel Overlap

- Factory standard
- Right over left overlap only
- Left over right overlap not available

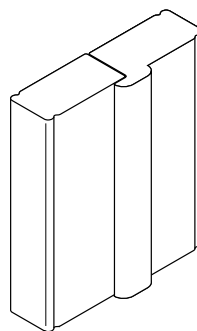

#### Astragal Style Panel Overlap

- No charge option
- Right over left overlap standard
- Left over right overlap optional
- Astragal will automatically be used between bifold panels

# Options

## Double Mouse Hole

- Has mouse hole on the rail above and below each louver section which allows the louvers to be closed in the upward or downward position
- Double mouse hole shutters will have tighter closure in the up position

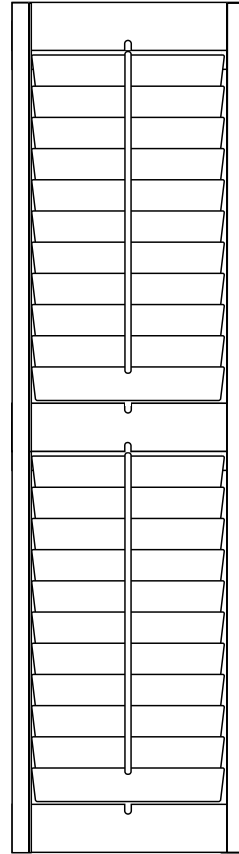
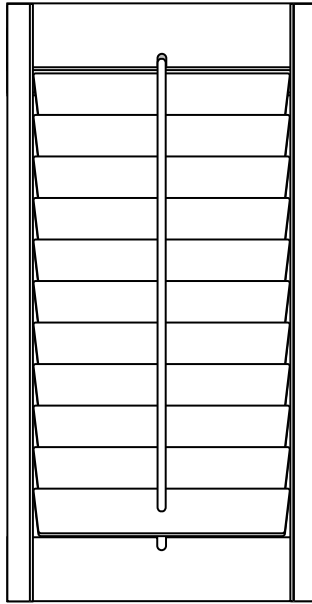

## Color Options

- Base White . . . . . 2051
- Creamy White . . . . . 2729
- Silk White . . . . . 2922

## Hardware Options

### Hinge Colors

Select the hardware color that best fits your decor:

- Antique Brass
- Off White
- Oil Rubbed Bronze
- Satin Nickel
- Stainless Steel
- White

5% surcharge

# Options

## Composite: Panel Configurations: Standard, Arch and Angled Top Shutters

Panel Configurations Must Be Selected From This Chart

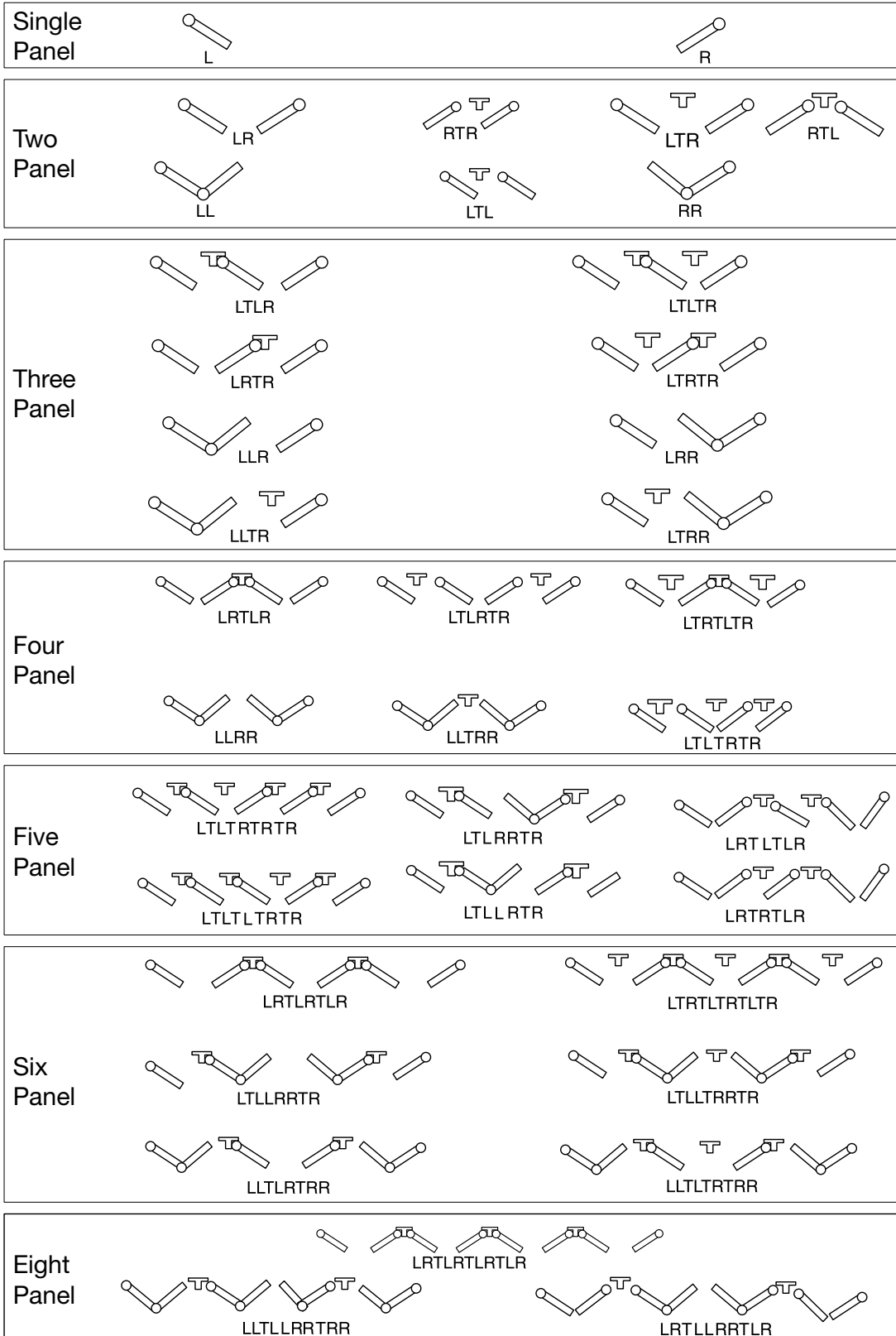



## Size Considerations

### Composite: Minimum and Maximum Width By Panel Configuration: 2½" and 3½" Louvers

Number Of Panels	Panel Configurations	Direct Mount, Hang Strip and Tilt-Out Z-Frame		Standard & Signature Z-Frames		L-Frame		Deco Frame	
		WO Size		WO Size		F-F Size		F-F Size	
		Minimum Width (inches)	Maximum Width (inches)	Minimum Width (inches)	Maximum Width (inches)	Minimum Width (inches)	Maximum Width (inches)	Minimum Width (inches)	Maximum Width (inches)
1 Panel	L, R	9 <sup>1</sup> / <sub>16</sub>	30 <sup>3</sup> / <sub>16</sub>	11	31 <sup>5</sup> / <sub>16</sub>	11 <sup>3</sup> / <sub>16</sub>	32 <sup>1</sup> / <sub>4</sub>	14 <sup>7</sup> / <sub>16</sub>	34 <sup>7</sup> / <sub>16</sub>
2 Panels	LR	18 <sup>1</sup> / <sub>16</sub>	60	19 <sup>7</sup> / <sub>8</sub>	61 <sup>11</sup> / <sub>16</sub>	20 <sup>7</sup> / <sub>16</sub>	62 <sup>1</sup> / <sub>16</sub>	24 <sup>11</sup> / <sub>16</sub>	64 <sup>11</sup> / <sub>16</sub>
	LTR, LTL, RTR, RTL	19 <sup>3</sup> / <sub>16</sub>	61 <sup>3</sup> / <sub>16</sub>	21 <sup>1</sup> / <sub>16</sub>	63 <sup>1</sup> / <sub>16</sub>	21 <sup>3</sup> / <sub>16</sub>	63 <sup>3</sup> / <sub>16</sub>	26 <sup>1</sup> / <sub>16</sub>	65 <sup>1</sup> / <sub>16</sub>
	LL, RR	18 <sup>1</sup> / <sub>16</sub>	48	19 <sup>7</sup> / <sub>8</sub>	49 <sup>11</sup> / <sub>16</sub>	20 <sup>7</sup> / <sub>16</sub>	50 <sup>1</sup> / <sub>16</sub>	24 <sup>11</sup> / <sub>16</sub>	56 <sup>11</sup> / <sub>16</sub>
3 Panels	LLR, LRR	27 <sup>3</sup> / <sub>16</sub>	78 <sup>3</sup> / <sub>16</sub>	29 <sup>1</sup> / <sub>16</sub>	80	29 <sup>1</sup> / <sub>4</sub>	80 <sup>1</sup> / <sub>4</sub>	24 <sup>11</sup> / <sub>16</sub>	82 <sup>11</sup> / <sub>16</sub>
	LLTR, LTRR	28 <sup>1</sup> / <sub>4</sub>	79 <sup>3</sup> / <sub>16</sub>	30 <sup>1</sup> / <sub>16</sub>	80 <sup>7</sup> / <sub>16</sub>	30 <sup>1</sup> / <sub>4</sub>	81 <sup>1</sup> / <sub>4</sub>	35 <sup>5</sup> / <sub>16</sub>	83 <sup>5</sup> / <sub>16</sub>
	LTLR, LRTR	28 <sup>1</sup> / <sub>4</sub>	79 <sup>3</sup> / <sub>16</sub>	30 <sup>1</sup> / <sub>16</sub>	92 <sup>7</sup> / <sub>16</sub>	30 <sup>1</sup> / <sub>4</sub>	93 <sup>1</sup> / <sub>4</sub>	35 <sup>5</sup> / <sub>16</sub>	95 <sup>5</sup> / <sub>16</sub>
	LTLTR, LTRTR	29 <sup>1</sup> / <sub>16</sub>	91 <sup>3</sup> / <sub>16</sub>	31 <sup>3</sup> / <sub>16</sub>	94 <sup>1</sup> / <sub>4</sub>	31 <sup>1</sup> / <sub>16</sub>	94 <sup>5</sup> / <sub>16</sub>	37 <sup>1</sup> / <sub>4</sub>	97 <sup>1</sup> / <sub>4</sub>
4 Panels	LLRR	36 <sup>1</sup> / <sub>16</sub>	92 <sup>3</sup> / <sub>16</sub>	38 <sup>7</sup> / <sub>16</sub>	97 <sup>5</sup> / <sub>16</sub>	38 <sup>1</sup> / <sub>16</sub>	97 <sup>11</sup> / <sub>16</sub>	44 <sup>9</sup> / <sub>16</sub>	100 <sup>9</sup> / <sub>16</sub>
	LLTRR	37 <sup>1</sup> / <sub>8</sub>	97	38 <sup>15</sup> / <sub>16</sub>	98 <sup>11</sup> / <sub>16</sub>	39 <sup>1</sup> / <sub>8</sub>	99 <sup>1</sup> / <sub>16</sub>	45 <sup>11</sup> / <sub>16</sub>	101 <sup>11</sup> / <sub>16</sub>
	LRTLRL	37 <sup>1</sup> / <sub>8</sub>	121	38 <sup>15</sup> / <sub>16</sub>	122 <sup>11</sup> / <sub>16</sub>	39 <sup>1</sup> / <sub>8</sub>	123 <sup>1</sup> / <sub>16</sub>	45 <sup>11</sup> / <sub>16</sub>	125 <sup>11</sup> / <sub>16</sub>
	LTLRTR	38 <sup>7</sup> / <sub>16</sub>	122 <sup>3</sup> / <sub>8</sub>	40 <sup>1</sup> / <sub>4</sub>	124 <sup>1</sup> / <sub>16</sub>	40 <sup>7</sup> / <sub>16</sub>	124 <sup>1</sup> / <sub>16</sub>	47 <sup>1</sup> / <sub>16</sub>	126 <sup>1</sup> / <sub>16</sub>
	LTRTLRL, LTLRTRR	39 <sup>1</sup> / <sub>4</sub>	123 <sup>1</sup> / <sub>4</sub>	41 <sup>1</sup> / <sub>16</sub>	125 <sup>1</sup> / <sub>16</sub>	41 <sup>1</sup> / <sub>4</sub>	125 <sup>3</sup> / <sub>16</sub>	48 <sup>7</sup> / <sub>16</sub>	128 <sup>7</sup> / <sub>16</sub>
5 Panels	LTLRRTL, LTLRTRR	47 <sup>3</sup> / <sub>16</sub>	140 <sup>1</sup> / <sub>16</sub>	51 <sup>1</sup> / <sub>4</sub>	143 <sup>15</sup> / <sub>16</sub>	51 <sup>3</sup> / <sub>16</sub>	144 <sup>11</sup> / <sub>16</sub>	61 <sup>1</sup> / <sub>16</sub>	149 <sup>9</sup> / <sub>16</sub>
	LRTLRLR, LRRTLRL	47 <sup>1</sup> / <sub>16</sub>	152 <sup>5</sup> / <sub>16</sub>	50 <sup>15</sup> / <sub>16</sub>	155 <sup>15</sup> / <sub>16</sub>	51 <sup>1</sup> / <sub>16</sub>	159 <sup>1</sup> / <sub>16</sub>	55 <sup>7</sup> / <sub>16</sub>	165 <sup>1</sup> / <sub>16</sub>
	LTLRTRRL, LTLRTRRR	50 <sup>1</sup> / <sub>16</sub>	154 <sup>15</sup> / <sub>16</sub>	51 <sup>3</sup> / <sub>16</sub>	156 <sup>3</sup> / <sub>16</sub>	52 <sup>1</sup> / <sub>16</sub>	157	60 <sup>3</sup> / <sub>16</sub>	159 <sup>3</sup> / <sub>16</sub>
6 Panels	LTLRRLR	56 <sup>11</sup> / <sub>16</sub>	158 <sup>1</sup> / <sub>16</sub>	58 <sup>1</sup> / <sub>2</sub>	160 <sup>3</sup> / <sub>16</sub>	58 <sup>1</sup> / <sub>16</sub>	160 <sup>1</sup> / <sub>16</sub>	67 <sup>1</sup> / <sub>16</sub>	163 <sup>3</sup> / <sub>16</sub>
	LLTLRRL	56 <sup>3</sup> / <sub>16</sub>	158 <sup>3</sup> / <sub>16</sub>	58	160 <sup>1</sup> / <sub>16</sub>	58 <sup>3</sup> / <sub>16</sub>	160 <sup>1</sup> / <sub>16</sub>	67 <sup>1</sup> / <sub>16</sub>	163 <sup>3</sup> / <sub>16</sub>
	LRTLRLR	56 <sup>1</sup> / <sub>16</sub>	182	58	183 <sup>11</sup> / <sub>16</sub>	58 <sup>1</sup> / <sub>16</sub>	184 <sup>1</sup> / <sub>16</sub>	67 <sup>1</sup> / <sub>16</sub>	187 <sup>1</sup> / <sub>16</sub>
	LTLRRLR, LLTLRRLR	57 <sup>1</sup> / <sub>2</sub>	159 <sup>3</sup> / <sub>8</sub>	59 <sup>9</sup> / <sub>16</sub>	161 <sup>1</sup> / <sub>16</sub>	59 <sup>1</sup> / <sub>2</sub>	161 <sup>1</sup> / <sub>16</sub>	68 <sup>1</sup> / <sub>16</sub>	164 <sup>1</sup> / <sub>16</sub>
	LRTLRLRL	60 <sup>1</sup> / <sub>4</sub>	186 <sup>3</sup> / <sub>8</sub>	62 <sup>1</sup> / <sub>16</sub>	187 <sup>13</sup> / <sub>16</sub>	62 <sup>1</sup> / <sub>4</sub>	188 <sup>3</sup> / <sub>16</sub>	70 <sup>13</sup> / <sub>16</sub>	190 <sup>13</sup> / <sub>16</sub>
8 Panels	LRTLRLRLR	75 <sup>3</sup> / <sub>4</sub>	243 <sup>1</sup> / <sub>4</sub>	77 <sup>1</sup> / <sub>16</sub>	245 <sup>1</sup> / <sub>16</sub>	77 <sup>3</sup> / <sub>4</sub>	247	80 <sup>1</sup> / <sub>2</sub>	250 <sup>1</sup> / <sub>2</sub>
	LRTLRLRLR	73 <sup>15</sup> / <sub>16</sub>	217 <sup>15</sup> / <sub>16</sub>	75 <sup>3</sup> / <sub>4</sub>	219 <sup>3</sup> / <sub>4</sub>	75 <sup>15</sup> / <sub>16</sub>	219 <sup>15</sup> / <sub>16</sub>	79 <sup>3</sup> / <sub>16</sub>	223 <sup>3</sup> / <sub>16</sub>
	LLTLRRLR	73 <sup>15</sup> / <sub>16</sub>	193 <sup>15</sup> / <sub>16</sub>	75 <sup>3</sup> / <sub>4</sub>	195 <sup>3</sup> / <sub>4</sub>	75 <sup>15</sup> / <sub>16</sub>	195 <sup>15</sup> / <sub>16</sub>	79 <sup>3</sup> / <sub>16</sub>	198 <sup>3</sup> / <sub>16</sub>

## Size Considerations

### Composite: Minimum and Maximum Width By Panel Configuration: 4½" Louvers

Number Of Panels	Panel Configurations	Direct Mount, Hang Strip and Tilt-Out Z-Frame		Standard & Signature Z-Frames		L-Frame		Deco Frame	
		WO Size		WO Size		F-F Size		F-F Size	
		Minimum Width (inches)	Maximum Width (inches)	Minimum Width (inches)	Maximum Width (inches)	Minimum Width (inches)	Maximum Width (inches)	Minimum Width (inches)	Maximum Width (inches)
1 Panel	L, R	9 <sup>1</sup> / <sub>16</sub>	26 <sup>3</sup> / <sub>16</sub>	9 <sup>1</sup> / <sub>16</sub>	27 <sup>7</sup> / <sub>8</sub>	11 <sup>1</sup> / <sub>16</sub>	28 <sup>1</sup> / <sub>4</sub>	14 <sup>7</sup> / <sub>8</sub>	30 <sup>7</sup> / <sub>8</sub>
2 Panels	LR	18 <sup>1</sup> / <sub>16</sub>	52	18 <sup>1</sup> / <sub>16</sub>	53 <sup>11</sup> / <sub>16</sub>	20 <sup>1</sup> / <sub>16</sub>	54 <sup>1</sup> / <sub>16</sub>	24 <sup>11</sup> / <sub>16</sub>	56 <sup>11</sup> / <sub>16</sub>
	LTR, LTL, RTR, RTL	19 <sup>9</sup> / <sub>16</sub>	53 <sup>9</sup> / <sub>16</sub>	19 <sup>9</sup> / <sub>16</sub>	55 <sup>11</sup> / <sub>16</sub>	21 <sup>9</sup> / <sub>16</sub>	55 <sup>7</sup> / <sub>16</sub>	26 <sup>1</sup> / <sub>16</sub>	58 <sup>1</sup> / <sub>16</sub>
	LL, RR	18 <sup>1</sup> / <sub>16</sub>	48	18 <sup>1</sup> / <sub>16</sub>	49 <sup>11</sup> / <sub>16</sub>	20 <sup>1</sup> / <sub>16</sub>	50 <sup>1</sup> / <sub>16</sub>	24 <sup>11</sup> / <sub>16</sub>	52 <sup>11</sup> / <sub>16</sub>
3 Panels	LLR, LRR	27 <sup>3</sup> / <sub>16</sub>	74 <sup>3</sup> / <sub>16</sub>	27 <sup>3</sup> / <sub>16</sub>	76	29 <sup>1</sup> / <sub>4</sub>	76 <sup>1</sup> / <sub>4</sub>	24 <sup>11</sup> / <sub>16</sub>	78 <sup>11</sup> / <sub>16</sub>
	LLTR, LTRR	28 <sup>1</sup> / <sub>4</sub>	75 <sup>3</sup> / <sub>16</sub>	28 <sup>1</sup> / <sub>4</sub>	76 <sup>7</sup> / <sub>8</sub>	30 <sup>1</sup> / <sub>4</sub>	77 <sup>1</sup> / <sub>4</sub>	35 <sup>7</sup> / <sub>8</sub>	79 <sup>7</sup> / <sub>8</sub>
	LTLR, LRTR	28 <sup>1</sup> / <sub>4</sub>	79 <sup>9</sup> / <sub>16</sub>	28 <sup>1</sup> / <sub>4</sub>	74 <sup>3</sup> / <sub>8</sub>	30 <sup>1</sup> / <sub>4</sub>	81 <sup>1</sup> / <sub>4</sub>	35 <sup>7</sup> / <sub>8</sub>	83 <sup>3</sup> / <sub>8</sub>
	LTLTR, LTRTR	29 <sup>9</sup> / <sub>16</sub>	80 <sup>9</sup> / <sub>16</sub>	29 <sup>9</sup> / <sub>16</sub>	82 <sup>1</sup> / <sub>4</sub>	31 <sup>9</sup> / <sub>16</sub>	82 <sup>5</sup> / <sub>8</sub>	37 <sup>1</sup> / <sub>4</sub>	85 <sup>1</sup> / <sub>4</sub>
4 Panels	LLRR	36 <sup>5</sup> / <sub>16</sub>	95 <sup>5</sup> / <sub>8</sub>	36 <sup>5</sup> / <sub>16</sub>	97 <sup>5</sup> / <sub>16</sub>	38 <sup>5</sup> / <sub>16</sub>	97 <sup>11</sup> / <sub>16</sub>	44 <sup>5</sup> / <sub>16</sub>	100 <sup>5</sup> / <sub>16</sub>
	LLTRR	37 <sup>7</sup> / <sub>8</sub>	97	37 <sup>7</sup> / <sub>8</sub>	98 <sup>11</sup> / <sub>16</sub>	39 <sup>7</sup> / <sub>8</sub>	99 <sup>1</sup> / <sub>16</sub>	45 <sup>11</sup> / <sub>16</sub>	101 <sup>11</sup> / <sub>16</sub>
	LRTLRL	37 <sup>7</sup> / <sub>8</sub>	105	37 <sup>7</sup> / <sub>8</sub>	106 <sup>11</sup> / <sub>16</sub>	39 <sup>7</sup> / <sub>8</sub>	107 <sup>1</sup> / <sub>16</sub>	45 <sup>11</sup> / <sub>16</sub>	109 <sup>11</sup> / <sub>16</sub>
	LTLRTR	38 <sup>7</sup> / <sub>16</sub>	106 <sup>3</sup> / <sub>8</sub>	38 <sup>7</sup> / <sub>16</sub>	108 <sup>1</sup> / <sub>16</sub>	40 <sup>7</sup> / <sub>16</sub>	108 <sup>7</sup> / <sub>16</sub>	47 <sup>1</sup> / <sub>16</sub>	111 <sup>1</sup> / <sub>16</sub>
	LTRLTR, LTLRTR	39 <sup>1</sup> / <sub>4</sub>	107 <sup>1</sup> / <sub>4</sub>	39 <sup>1</sup> / <sub>4</sub>	109 <sup>9</sup> / <sub>16</sub>	41 <sup>1</sup> / <sub>4</sub>	109 <sup>9</sup> / <sub>16</sub>	48 <sup>7</sup> / <sub>16</sub>	112 <sup>7</sup> / <sub>16</sub>
5 Panels	LTLRRTR, LTLRTR	47 <sup>7</sup> / <sub>8</sub>	128 <sup>8</sup> / <sub>16</sub>	47 <sup>7</sup> / <sub>8</sub>	131 <sup>15</sup> / <sub>16</sub>	51 <sup>7</sup> / <sub>8</sub>	42 <sup>11</sup> / <sub>16</sub>	61 <sup>7</sup> / <sub>16</sub>	147 <sup>7</sup> / <sub>16</sub>
	LRTLRLR, LRTRRLR	47 <sup>7</sup> / <sub>16</sub>	132 <sup>2</sup> / <sub>16</sub>	47 <sup>7</sup> / <sub>16</sub>	135 <sup>15</sup> / <sub>16</sub>	51 <sup>7</sup> / <sub>16</sub>	139 <sup>3</sup> / <sub>16</sub>	55 <sup>7</sup> / <sub>16</sub>	145 <sup>7</sup> / <sub>16</sub>
	LTLRTRTR, LTLRTRTR	50 <sup>1</sup> / <sub>16</sub>	142 <sup>15</sup> / <sub>16</sub>	50 <sup>1</sup> / <sub>16</sub>	144 <sup>9</sup> / <sub>8</sub>	52 <sup>1</sup> / <sub>16</sub>	145	60 <sup>7</sup> / <sub>8</sub>	147 <sup>7</sup> / <sub>8</sub>
6 Panels	LTLRRLRTR	56 <sup>11</sup> / <sub>16</sub>	150 <sup>9</sup> / <sub>16</sub>	56 <sup>11</sup> / <sub>16</sub>	152 <sup>3</sup> / <sub>8</sub>	58 <sup>11</sup> / <sub>16</sub>	152 <sup>9</sup> / <sub>16</sub>	67 <sup>7</sup> / <sub>16</sub>	155 <sup>3</sup> / <sub>16</sub>
	LLTLRTRR	56 <sup>5</sup> / <sub>16</sub>	150 <sup>3</sup> / <sub>8</sub>	56 <sup>5</sup> / <sub>16</sub>	159 <sup>11</sup> / <sub>16</sub>	58 <sup>5</sup> / <sub>16</sub>	152 <sup>7</sup> / <sub>16</sub>	67 <sup>7</sup> / <sub>16</sub>	155 <sup>7</sup> / <sub>16</sub>
	LRTLRLTR	56 <sup>5</sup> / <sub>16</sub>	158	56 <sup>5</sup> / <sub>16</sub>	153 <sup>1</sup> / <sub>16</sub>	58 <sup>5</sup> / <sub>16</sub>	160 <sup>1</sup> / <sub>16</sub>	67 <sup>7</sup> / <sub>16</sub>	163 <sup>1</sup> / <sub>16</sub>
	LTLRRLRTR, LLTLRTRTR	57 <sup>1</sup> / <sub>2</sub>	151 <sup>1</sup> / <sub>8</sub>	57 <sup>1</sup> / <sub>2</sub>	163 <sup>13</sup> / <sub>16</sub>	59 <sup>1</sup> / <sub>2</sub>	153 <sup>3</sup> / <sub>16</sub>	68 <sup>7</sup> / <sub>16</sub>	156 <sup>7</sup> / <sub>16</sub>
	LTRLRTRLTR	60 <sup>1</sup> / <sub>4</sub>	162 <sup>3</sup> / <sub>8</sub>	60 <sup>1</sup> / <sub>4</sub>	213 <sup>9</sup> / <sub>16</sub>	62 <sup>1</sup> / <sub>4</sub>	164 <sup>3</sup> / <sub>16</sub>	70 <sup>9</sup> / <sub>16</sub>	166 <sup>3</sup> / <sub>16</sub>
8 Panels	LRTLRLRTR	75 <sup>1</sup> / <sub>4</sub>	211 <sup>1</sup> / <sub>4</sub>	75 <sup>1</sup> / <sub>4</sub>	203 <sup>3</sup> / <sub>4</sub>	77 <sup>1</sup> / <sub>4</sub>	215	80 <sup>1</sup> / <sub>2</sub>	217 <sup>1</sup> / <sub>4</sub>
	LRTLRLRTR	73 <sup>15</sup> / <sub>16</sub>	201 <sup>15</sup> / <sub>16</sub>	73 <sup>15</sup> / <sub>16</sub>	203 <sup>1</sup> / <sub>4</sub>	75 <sup>15</sup> / <sub>16</sub>	203 <sup>15</sup> / <sub>16</sub>	79 <sup>9</sup> / <sub>16</sub>	207 <sup>9</sup> / <sub>16</sub>
	LLTLRRLRTR	73 <sup>15</sup> / <sub>16</sub>	193 <sup>15</sup> / <sub>16</sub>	73 <sup>15</sup> / <sub>16</sub>	195 <sup>1</sup> / <sub>4</sub>	75 <sup>15</sup> / <sub>16</sub>	195 <sup>15</sup> / <sub>16</sub>	79 <sup>9</sup> / <sub>16</sub>	198 <sup>3</sup> / <sub>16</sub>

## Size Considerations

Composite: Minimum and Maximum Height By Frame Type			
Frame Configuration	Frame Type	Minimum (inches)	Maximum (inches)
2-Sided	Hang strip/direct mount	15 <sup>1</sup> / <sub>4</sub>	96 <sup>1</sup> / <sub>4</sub>
2-Sided	Z-Frames	15 <sup>1</sup> / <sub>4</sub>	96 <sup>1</sup> / <sub>4</sub>
3-Sided and 3-Sided Invert	Z-Frames	16 <sup>1</sup> / <sub>16</sub>	97 <sup>1</sup> / <sub>16</sub>
3-Sided Sill Top or Bottom	Z-Frames	16 <sup>1</sup> / <sub>16</sub>	97 <sup>1</sup> / <sub>16</sub>
4-Sided with Sill Top or Bottom	Z-Frames	16 <sup>1</sup> / <sub>2</sub>	97 <sup>1</sup> / <sub>2</sub>
4-Sided with Sill Top and Bottom	Z-Frames	16	97
4-Sided	Z-Frames	16 <sup>15</sup> / <sub>16</sub>	97 <sup>15</sup> / <sub>16</sub>
2-Sided	Tilt-Out Z-Frame	15 <sup>1</sup> / <sub>4</sub>	96 <sup>1</sup> / <sub>4</sub>
3-Sided and 3-Sided Invert	Tilt-Out Z-Frame	15 <sup>1</sup> / <sub>4</sub>	96 <sup>1</sup> / <sub>4</sub>
3-Sided Sill Top or Bottom	Tilt-Out Z-Frame	15 <sup>5</sup> / <sub>8</sub>	96 <sup>5</sup> / <sub>8</sub>
4-Sided with Sill Top or Bottom	Tilt-Out Z-Frame	15 <sup>3</sup> / <sub>4</sub>	96 <sup>3</sup> / <sub>4</sub>
4-Sided with Sill Top and Bottom	Tilt-Out Z-Frame	16	97
4-Sided	Tilt-Out Z-Frame	15 <sup>1</sup> / <sub>4</sub>	96 <sup>1</sup> / <sub>4</sub>
2-Sided	L-Frame	15 <sup>1</sup> / <sub>4</sub>	96 <sup>1</sup> / <sub>4</sub>
3-Sided and 3-Sided Invert	L-Frame	16 <sup>5</sup> / <sub>16</sub>	97 <sup>1</sup> / <sub>4</sub>
3-Sided Sill Top or Bottom	L-Frame	16 <sup>1</sup> / <sub>16</sub>	97 <sup>5</sup> / <sub>8</sub>
4-Sided with Sill Top or Bottom	L-Frame	16 <sup>5</sup> / <sub>8</sub>	97 <sup>5</sup> / <sub>8</sub>
4-Sided with Sill Top and Bottom	L-Frame	16	97
4-Sided	L-Frame	17 <sup>7</sup> / <sub>16</sub>	98 <sup>1</sup> / <sub>4</sub>
2-Sided	Deco Frame	15 <sup>1</sup> / <sub>4</sub>	96 <sup>1</sup> / <sub>4</sub>
3-Sided and 3-Sided Invert	Deco Frame	17 <sup>7</sup> / <sub>16</sub>	98 <sup>9</sup> / <sub>16</sub>
3-Sided Sill Top or Bottom	Deco Frame	15 <sup>5</sup> / <sub>8</sub>	96 <sup>5</sup> / <sub>8</sub>
4-Sided with Sill Top or Bottom	Deco Frame	17 <sup>15</sup> / <sub>16</sub>	98 <sup>15</sup> / <sub>16</sub>
4-Sided with Sill Top and Bottom	Deco Frame	16	97
4-Sided	Deco Frame	19 <sup>7</sup> / <sub>8</sub>	100 <sup>7</sup> / <sub>8</sub>

# Options

## Frame Type Decision Tree

Review window and the area around the window. Choose from the options below.

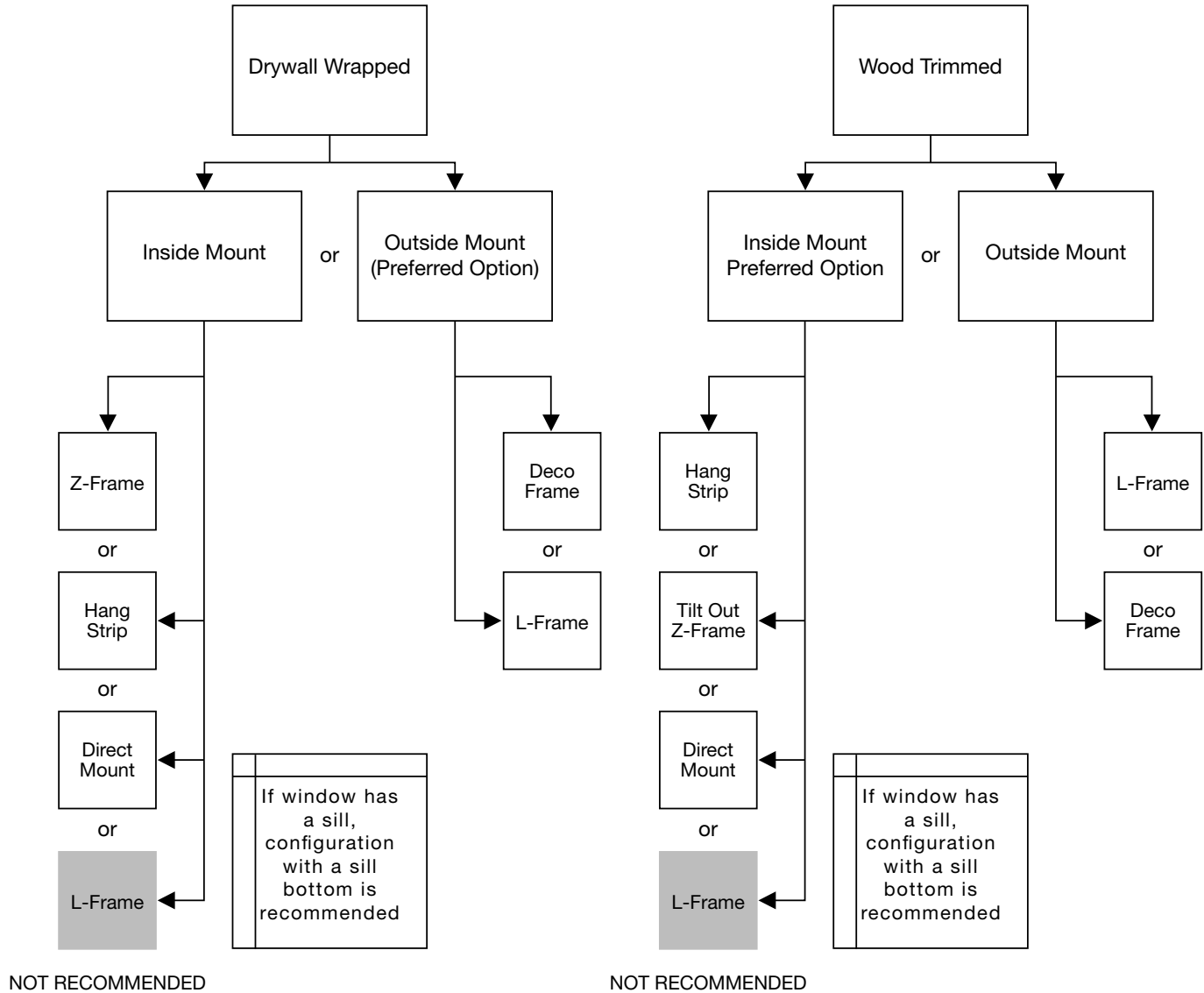

# Options

## Measuring For Standard Shutters

### Confirm that the window is square.

Measure the diagonals. If the difference between the two measurements is greater than  $\frac{1}{4}$ ", an outside mount shutter is required.

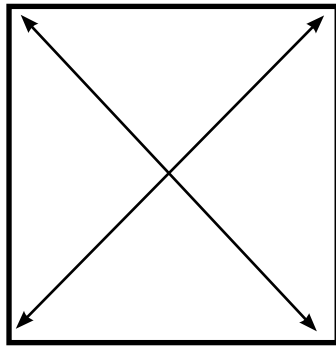

Square

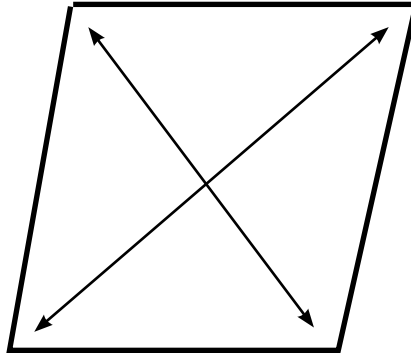

Not Square

### Window Opening Measurement

#### Inside Mount with Hang Strips, Direct Mount, Z-Frame, Tilt-Out Z-Frame

- Measure the width at three points and the height at three points; use the smallest width and height measurements

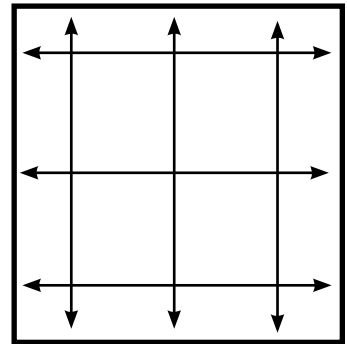

**NOTE:** Factory makes no allowances/deductions for Tilt-Out Z-Frame.

### Frame-to-Frame Measurement

#### Required for L-Frame and Deco Frame

- Place a sample of the L-Frame or Deco frame on the window frame or wall to determine frame-to-frame placement
- Measure frame-to-frame width at three points and frame-to-frame height at three points; use the largest width and height measurements

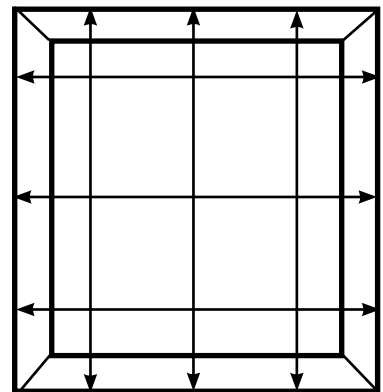

**NOTE:** At least 1% flat surface is needed on each side of the window for an L-Frame.

**HELPFUL HINT:** If shutters are in the same room and/or side by side, shutters must be ordered at the same height to ensure rail height, divider rail location, louver count and hinge quantity will match.

# Options

## Measuring Divider Rail Location

Always start from the bottom point of measure to center of the desired divider rail location.

To measure frame-to-frame, measure from the bottom of the shutter frame up to the center of the desired rail location.

To measure window opening, measure from the sill or bottom of the window opening to the center of the desired rail location.

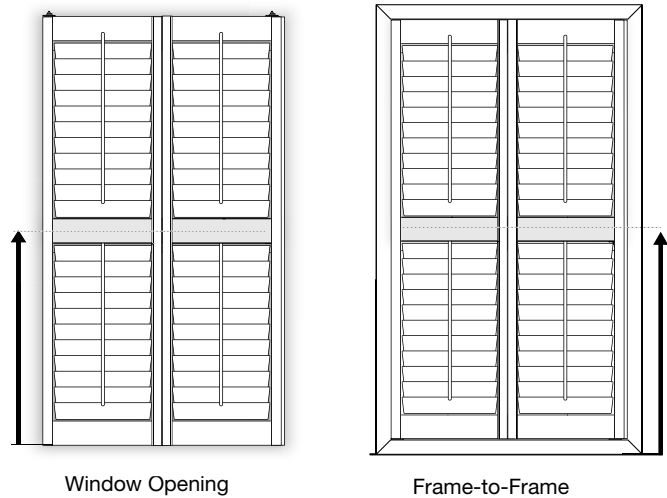

**NOTE:** Top and bottom rails may be unequal due to requested location and louver spacing. Rail sizes vary from 3"-6".

## Divider Rail Requirements

1. Divider rails are required over 72" height for added strength.
2. Divider rail can be requested (when not required) for design purposes.
3. A 3" divider rail is used with all louver sizes.
4. Divider rails for 2½" and 3½" louvers will be as specified (exact) on order.
5. Factory may shift rail up or down, (+/- 2") to achieve uniform louver spacing in 4½" louvers only.
6. Minimum louver set is 2 louvers in each section.

**HELPFUL HINT:** If shutters are in the same room and/or side by side, shutters must be ordered at the same height to ensure divider rail location will match.

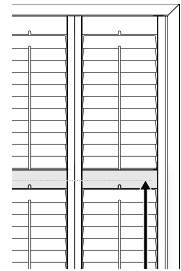

**NOTE:** Top and bottom rail sizes may vary and/or be unequal due to requested location and louver spacing. Rail sizes vary from 3"-6".

## Measuring T-Post Locations

Always start from the left point of measure type to the center of the desired T-Post location.

To measure frame-to-frame, measure from the left of the shutter frame to the center of the desired T-Post location.

To measure the window opening, measure from the left inside of the window opening to the center of the desired T-Post location.

If there is more than one T-Post, measure from the left of measure type to the center of first T-Post location, then measure from the left of measure type over to the center of the second T-Post location etc.

**EXAMPLE:** A-B, A-C, A-D

Always measure from the same point the frame was measured.

**EXAMPLE:** If measuring for L-Frame, frame-to-frame measure type, A is the outside edge of the L-Frame.

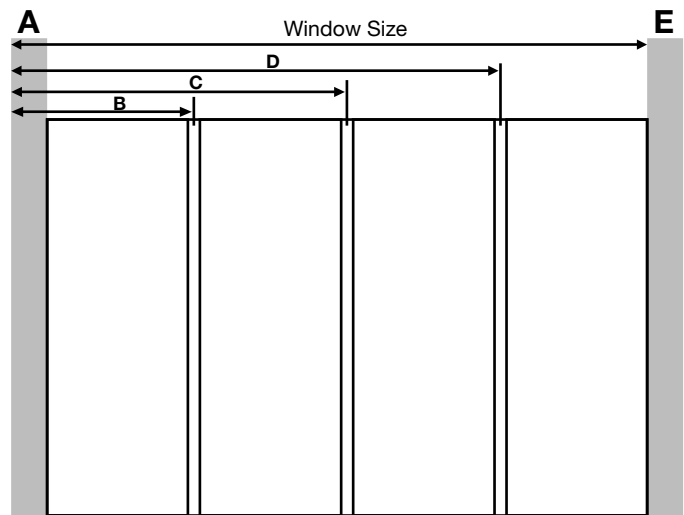

# Options

## Proper Application of the Tilt-Out Z-Frame

### Tilt-Out Z-Frame (Inside Mount)

Designed to be used with certain styles of window trim. Panel and frame are pre-hinged. Frame is not pre-drilled. Shipment includes self-tapping "trim-head" screws.

Tilt-Out Z-Frame must be ordered as "Window Opening" (WO) size. NO factory deduction is made with this frame.

Factory Deductions: Width: 0"

Height: 0"

**NOTE:** Installer MUST make own deductions for proper fit. If diagonal measurements exceed  $\frac{1}{8}$ " out of square, use other outside mount frame style.

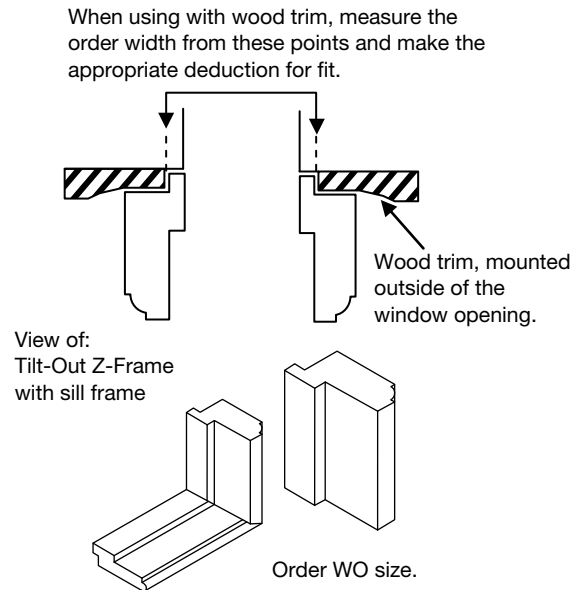

## Sill Cap Application

### Ordering options:

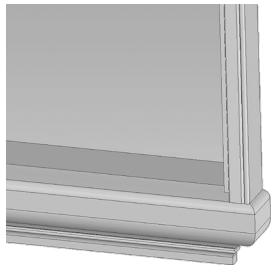

Flush with frame

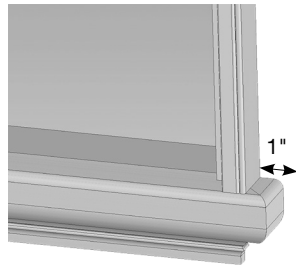

1" overlap

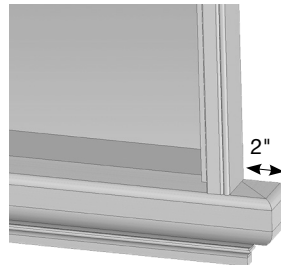

2" overlap

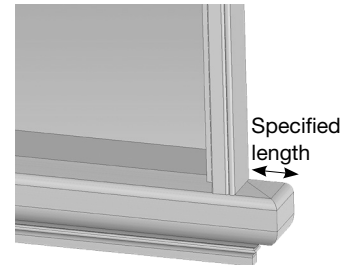

Specified length

### 3 available frame configuration options:

- 4-sided with sill cap bottom
- 3-sided invert with sill cap bottom
- 4-sided with sill frame top and sill cap bottom

Existing sill length on window will be required when ordering. This is to assure that sill cap option ordered will fit over the top of your existing window sill. A  $1\frac{5}{8}$ " buildout will be provided to take up the gap between the existing sill and any inside mount frame. This buildout will be butted up to the back edge of the sill cap to extend the length.

The sill cap will sit flush against the wall for window sills protruding up to  $\frac{1}{4}$ " from the face of the wall. The sill cap can be used on longer sills but there will be a gap between the wall and the sill cap.

**NOTE:** No mounting hardware included. Adhesive should be used to attach sill cap to window sill. Made of wood material only. Not available on composite specialties.

# Specifications

## Composite Frame Product Detail

### Direct Mount

- Inside mount only
- Window opening measure only
- Panel is pre-hinged
- Four light blocks included
- Factory automatically makes deductions: Width- $\frac{1}{4}$ ", Height- $\frac{1}{4}$ "

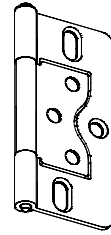

Frame Hinge

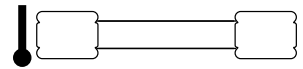

Example: 1-panel L

### Hang Strip

- Inside mount only
- Window opening measure
- Includes adjustable wrap-around hinge for easy installation
- Panel and hang strip are pre-hinged
- Hang strip is pre-drilled
- Top and bottom light blocks included
- Factory automatically makes deductions: Width- $\frac{1}{4}$ ", Height- $\frac{1}{4}$ "

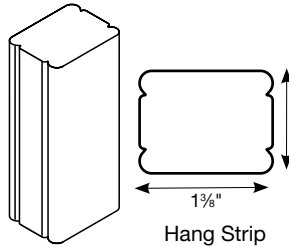

Hang Strip

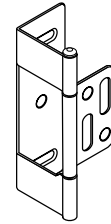

Hang Strip Hinge

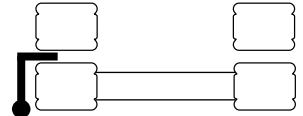

Example: 1-panel L

### Z-Frames

- Inside mount only
- Window opening measure only
- Panel and frame are pre-hinged
- Frame is not pre-drilled
- Standard, Signature—factory automatically makes deductions: Width- $\frac{5}{16}$ ", for Height see Z-Frame configuration chart
- No deduction taken on Tilt-Out Z-Frame, measurement is the same as the window opening see tilt-out-frame section

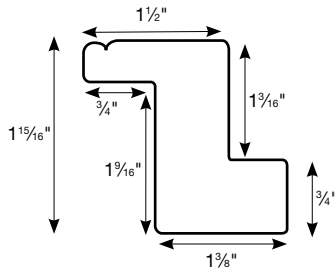

Standard Z-Frame

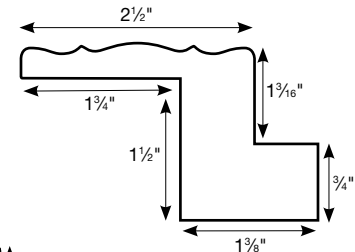

Signature Z-Frame

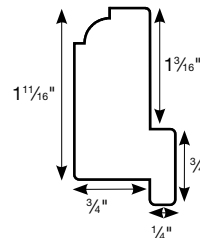

Tilt-Out Z-Frame

### L-Frame

- Recommended outside mount only
- Frame-to-frame measure only
- Panel and frame are pre-hinged
- Frame is not pre-drilled
- No factory deduction made
  - If using for inside mount or a tight spot, installer must make own deduction for proper fit and order as frame-to-frame

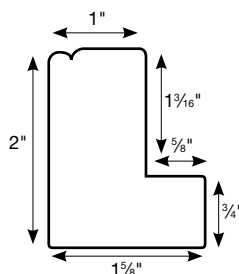

Standard L-Frame

### Deco Frame

- Outside mount only
- Frame-to-frame measure only
- Panel and frame are pre-hinged
- Frame is not pre-drilled
- No factory deduction made
  - If using in a tight spot, installer must make own deduction for proper fit and order as frame-to-frame

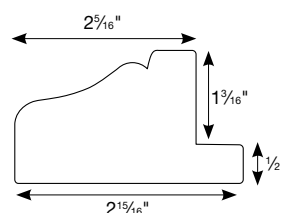

Deco Frame

**NOTE:** Frames larger than 115" require splicing.



# Specifications

## Composite Frame Product Detail

### Sill Cap

- Available with all frames
- Available with following frame configurations: 3-sided inverted with sill cap bottom, 4-sided with sill cap bottom, 4-sided with sill frame top and sill cap bottom
- Buildout included (1 $\frac{5}{8}$ " x 1 $\frac{1}{2}$ " )

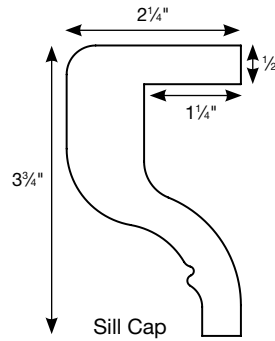

### Sill Frame

- Offered with L-Frame, Z-Frame and Deco Frame
- Not available with Buildouts

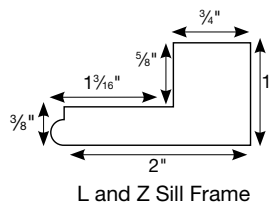

L and Z Sill Frame

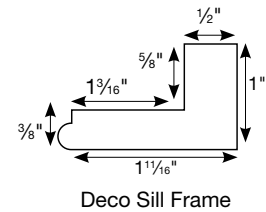

Deco Sill Frame

### Sill Frame with Frame

- Sill frame is attached to side frame and joined together via screws

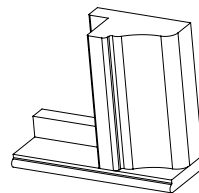

Composite Deco Frame with Sill

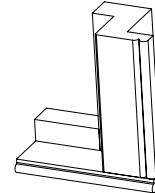

Composite Z-Frame with Sill

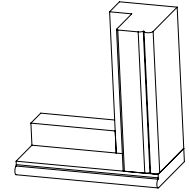

Composite L-Frame with Sill

### Light Block

- Included with hang strip, direct mount, 2-sided and 3-sided frame types

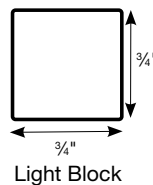

Light Block

### T-Post

- Vertical post that divides the shutter into multiple sections
- T-Post pre-drilled by factory

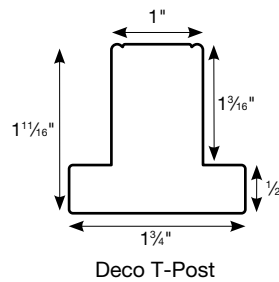

Deco T-Post

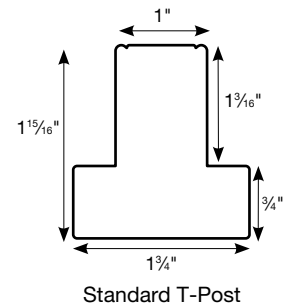

Standard T-Post

### Buildout

- Used with L-Frames and Deco Frames
- Available only in 1/2" increments
- Maximum 2" (4 pieces) per shutter
- Not available with sill configurations

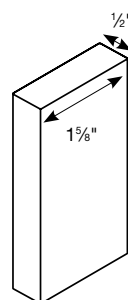

Buildout

(Maximum of 2", (4 pieces) per shutter; 1/2" (increments)

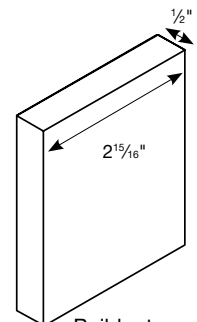

Buildout

(Maximum of 2", (4 pieces) per shutter; 1/2" (increments)

**NOTE:** Frames larger than 115" require splicing.

# Specifications

## Deductions for Frame Allowances

### Direct Mount

- Automatically taken at factory
- Width deduction— $\frac{1}{4}$ "
- Height deduction— $\frac{1}{4}$ "

### Hang Strip

- Automatically taken at factory
- Width deduction— $\frac{1}{4}$ "
- Height deduction— $\frac{1}{4}$ "

### Z-Frame (Standard and Signature)

- Automatically taken at factory

Z-Frame Configuration	Frame Width Deduction (inches)	Frame Height Deduction (inches)
2-Sided	- $\frac{5}{16}$	No deduction*
3-Sided or 3-Sided Inverted	- $\frac{5}{16}$	- $\frac{5}{32}$ *
3-Sided Sill Top or Bottom	- $\frac{5}{16}$	- $\frac{1}{16}$ *
4-Sided	- $\frac{5}{16}$	- $\frac{5}{16}$
4-Sided Sill Top or Bottom	- $\frac{5}{16}$	- $\frac{5}{32}$
4-Sided Sill Top and Bottom	- $\frac{5}{16}$	- $\frac{1}{16}$

\*Using this deduction, panel clearance on open ends of frame will automatically be  $\frac{1}{8}$ ".

**NOTE:** Factory makes no deductions on Tilt-Out Z-Frames, the measurement is the same as the window opening (see Tilt-Out Z-Frame section). You must take your own deductions on Tilt-Out Z-Frames.

### L-Frame

- No deductions taken at factory
- If using for inside mount or in a tight spot, installer must make own deduction for proper fit and order as frame to frame

### Deco Frame

- No deduction taken at factory
- If using in a tight spot, installer must make own deduction for proper fit and order as frame to frame

# Specifications

## Composite Frame Configurations

### 2-Sided

Hang strip and direct mount with inside mount is available only in 2-sided frame (vertical). We will provide the light block at no charge for hang strip with inside mount.

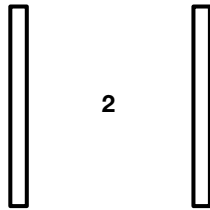

### 4-Sided with Sill Bottom

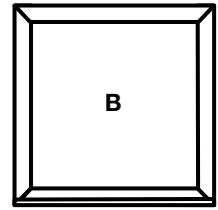

### 3-Sided

Light block included at no charge.

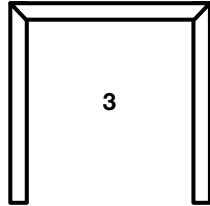

### 4-Sided with Sill Top

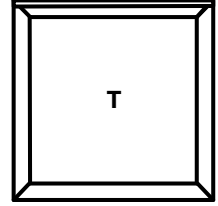

### 3-Sided Inverted

Light block included at no charge.

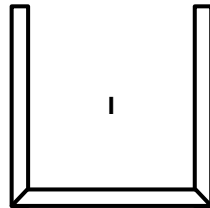

### 4-Sided

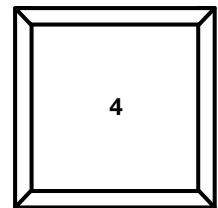

### 3-Sided with Sill Top

Light block included at no charge.

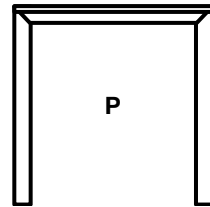

### 4-Sided with Sill Top and Bottom

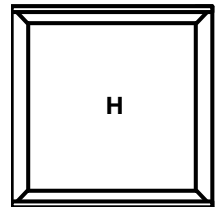

### 3-Sided Inverted with Sill Bottom

Light block included at no charge.

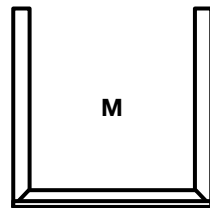

### 4-Sided with Sill Top and Sill Cap Bottom

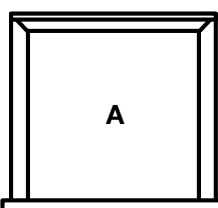

### 3-Sided inverted with Sill Cap Bottom

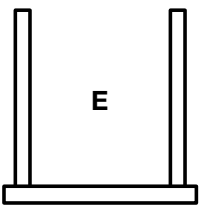

### 4-Sided with Sill Cap Bottom

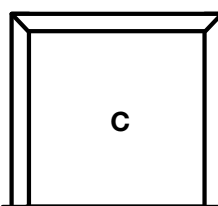

**NOTE:** Direct mount includes 4 light blocks at no charge.

**NOTE:** Sill Cap is made of wood only.

## Installation Hardware

### Included with order

- Hinge pins
- Installation screws (hinge, mounting, etc.)
- Hoffman keys

### Available upon request—contact Customer Service

- Hinge shims
- Louver pins
- Screws
- Screw caps (cover exposed screw heads)

# Specialty Styles

## Café Shutters

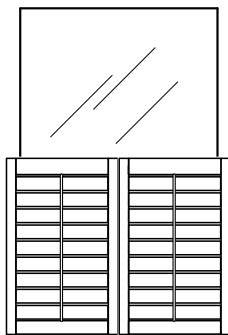

Shown as 2-Sided

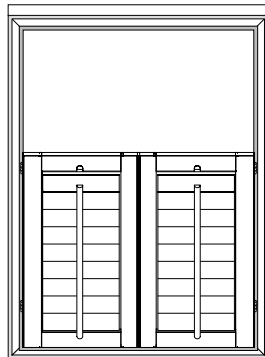

Shown as 4-Sided

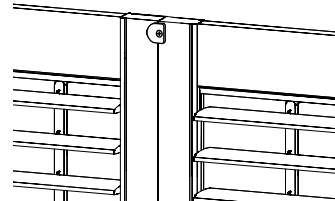

Rear view of Café Panel Optional:  
Café Aligning Catch

- Tops of composite panels are not finished and are not recommended
- Café shutter panels cover the lower portion of the window
- Pricing is based on width x café panel height
- Optional Café Aligning Catch
- Frame can be ordered to stop at panel height or can be ordered to fully frame the window

**ORDER ENTRY TIP:** When ordering frames to stop at panel height: 3-sided, 3-sided sill top or 4-sided with or without sill configurations must be entered as standard shutters. 2-sided, 3-sided inverted and 3-sided inverted sill bottom can be entered as cafe with panel and frame height the same size.

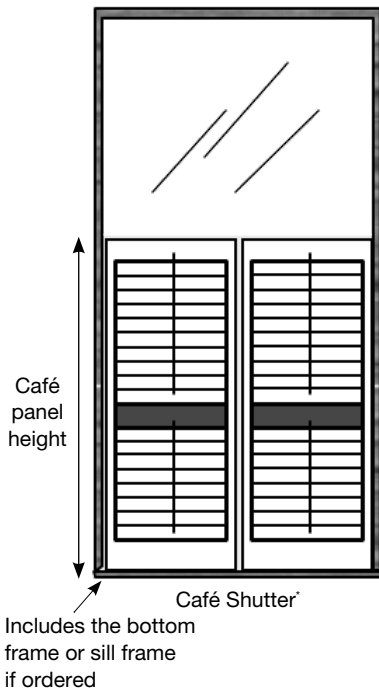

**Café is available in a variety of frames, both inside and outside mount.**

- Measure format depends on frame type selected
- For direct mount, use "window opening" size (WO) and no frame is furnished  
**NOTE:** Panel will be 1/8" smaller than café panel height ordered for bottom swing clearance.
- For hang strip, use "window opening" size (WO) and hang strip will be the same height as café panel  
**NOTE:** Panel will be 1/8" smaller than café panel height ordered for bottom swing clearance.
- For Z-Frame, use "window opening" size (WO) and frame can be made at same height café panel or be made at window height for "full-height frame"  
**NOTE:** The café panel height ordered will include whatever frame configuration ordered for the bottom. The cafe panel height is the height of the panels will stop at.
- For L-Frame and Deco frame, use "frame-to-frame" size (F-F) and frame can be made at the same height as café panel or be made at window height for "full-height frame"  
**NOTE:** The café panel height ordered will include whatever frame configuration ordered for the bottom. The cafe panel height is the height of the panels will stop at.

\*Shown with full window-height frame option.

# Specialty Styles

## Sunburst Arch Without Frame

### Specialty Shape Without Frame: Panel Only

- Sunburst pattern—no horizontal louvers
- Rabbeted louvers for maximum light control
- Louver sizes will vary based on height and width of arch
- The arch has no tilt bar; the louvers open individually and are spring loaded at the bottom pin
- Buildouts not available
- Panel is  $1\frac{1}{16}$ " thick and may not match projection of other outside mount standard shutters
- Order arch as frame-to-frame

- Allow sufficient wall space to mount. Panel-only arches that are:

Frameless Arch Base Width (inches)	Top Rail Size (inches)	Bottom Rail Size (inches)
24 to less than 45	2	1
45 to less than 72	3	2
45 to less than 80	3	3

**NOTE:** If mounting arch inside, take own deduction and order frame-to-frame. Template recommended.

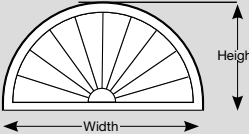
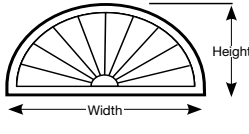
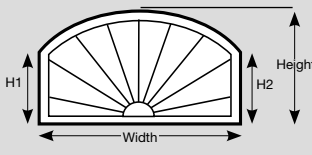
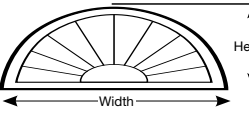
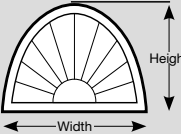
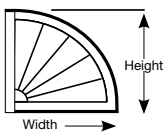
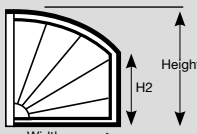
Specialty Shape without Frame: Minimum and Maximum Sizes					
Frameless—Panel Only		Width		Height	
		Minimum (inches)	Maximum (inches)	Minimum (inches)	Maximum (inches)
	Perfect Sunburst Arch (order as Eyebrow) Height = 50% of width No templates required	20	72	10	36
	Eyebrow Sunburst Height Minimum = no less than 33% of width Height Maximum = no greater than 66% of width Template required if height exceeds 54% of width	20	72	7	36
	Elongated Sunburst Height Minimum = no less than 33% of width Height Maximum = no greater than 66% of width Template required if ordered height minus ordered leg height exceeds 54% of width	20	72	10	47½
	Elliptical Sunburst (arch without a constant radius) Template always required	20	72	7	36
	Palladian Height Minimum = no less than 33% of width Height Maximum = no greater than 66% of width No template needed. Additional measurements required (see order form).	20	72	10	47½
	¼ Eyebrow Leg minimum = 33% of width Leg maximum = 108% of width	15	36	7	36
	¼ Elongated Sunburst Arch Leg minimum = 33% of width Leg maximum = 132% of width	15	36	10	47½



# Specialty Styles

## Sunburst Arch With Frame

Frame Options	Z-Frames*	L-Frames	Deco Frame
Mount	Inside Mount Only	Outside Mount Only	Outside Mount Only
Order Size	Window Opening	Frame-to-Frame	Frame-to-Frame
Projection	3/8"	2"	1 1/16"

Framed arches not available with Tilt-Out Z-Frame.

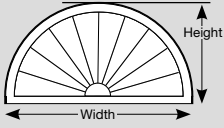
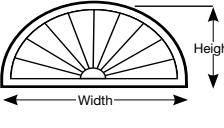
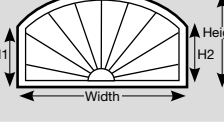
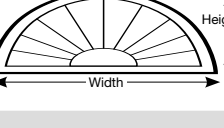
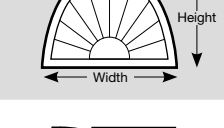
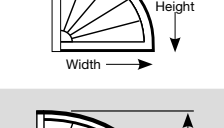
**NOTE:** All frame types are available with sill bottom Buildouts are available on L-Frame and Deco Frame arches (except with sill bottom).

Framed Full and 1/4 Sunburst Arches			Width		Height	
			Minimum (inches)	Maximum (inches)	Minimum (inches)	Maximum (inches)
	Perfect Sunburst Arch Height = 50% of width No templates required	Z-Frame	21 13/16	73 13/16	11 13/16	37 13/16
		L-Frame	22 1/8	74 1/8	12 1/8	38 1/8
		Deco Frame	24 3/4	76 3/4	14 3/4	40 3/4
	Eyebrow Sunburst Height Minimum = no less than 33% of width Height Maximum = no greater than 66% of width Template required if height exceeds 54% of width	Z-Frame	21 13/16	73 13/16	8 13/16	37 13/16
		L-Frame	22 1/8	74 1/8	9 1/8	38 1/8
		Deco Frame	24 3/4	76 3/4	11 3/4	40 3/4
	Elongated Sunburst Height Minimum = no less than 33% of width Height Maximum = no greater than 66% of width Template required if ordered height minus ordered leg height exceeds 54% of width	Z-Frame	21 13/16	73 13/16	11 13/16	49 13/16
		L-Frame	22 1/8	74 1/8	12 1/8	49 1/8
		Deco Frame	24 3/4	76 3/4	14 3/4	51 3/4
	Elliptical Sunburst Template always required.	Z-Frame	21 13/16	73 13/16	8 13/16	37 13/16
		L-Frame	22 1/8	74 1/8	9 1/8	38 1/8
		Deco Frame	24 3/4	76 3/4	11 3/4	40 3/4
	Palladian Height Minimum = no less than 33% of width Height Maximum = no greater than 66% of width No template needed; additional measurements required (see order form)	Z-Frame	21 13/16	73 13/16	8 13/16	49 13/16
		L-Frame	22 1/8	74 1/8	9 1/8	49 1/8
		Deco Frame	24 3/4	76 3/4	11 3/4	51 3/4
	1/4 Eyebrow Sunburst Arch Leg minimum = 33% of width Leg maximum = 108% of width	Z-Frame	16 13/16	37 13/16	8 13/16	37 13/16
		L-Frame	17 1/8	38 1/8	9 1/8	38 1/8
		Deco Frame	21 3/4	40 3/4	11 3/4	40 3/4
	1/4 Elongated Sunburst Arch Leg minimum = 33% of width Leg maximum = 132% of width	Z-Frame	16 13/16	37 13/16	11 13/16	49 13/16
		L-Frame	17 1/8	38 1/8	12 1/8	49 1/8
		Deco Frame	24 3/4	40 3/4	14 3/4	51 3/4

# Specialty Styles

## How to Make a Template (Recommended for Inside Mount Frameless Arches — Required for Elliptical Arches)

1. Tape paper over the window opening, allowing plenty of overlap. See below for template material information.
2. If your arch has a frame that requires a window opening measurement, draw an exact outline of the window opening. Manufacturing will take a deduction for proper fit. Be careful NOT to press in or crease the paper of the template while tracing. If your arch is frameless or has a frame that requires a F-F measurement, make template to the finished size you need. Your arch will be made to this size.
3. Remove the paper from the window opening and cut out the arch.
4. Place the template back on the window opening to verify size.
5. Mark the template with the following:
  - Room Side
  - Purchase Order Number
  - Customer's Name
  - Company Name and Account Number
  - Frame-to-frame measurement (width) of shutter panels below the arch if applicable
6. Attach a copy of the purchase order to the template.
7. Roll the template and place it in a mailing tube.
8. DO NOT FOLD the TEMPLATE!

9. Mail to: Springs Window Fashions  
8467 Route 405 South  
P.O. Box 500  
Mongomery, PA 17752  
Attn: Shutter Department

### Acceptable Materials for Making a Template\*

- Kraft type paper
- Butcher paper
- Lightweight poster paper that can be rolled without creasing

### Non-Acceptable Materials for Making a Template

- Newspaper
- Wrapping paper
- Tissue paper
- Fabrics
- Wood
- Wax paper

If the material used to make a template stretches, tears easily, will not lay flat after being rolled, or will mark the product in any way, Springs Window Fashions will refuse to use the template and require a new one.

\*Use only tape that will not pull off paint or wallpaper.

**NOTE:** Comment on Purchase Order if a template is being sent, otherwise order will be processed without.

Manufacturer will not add to template. Provide finished size for frameless arches or a framed arch that requires a F-F measurement. Manufacturing will deduct from Z-Frame window opening template size.

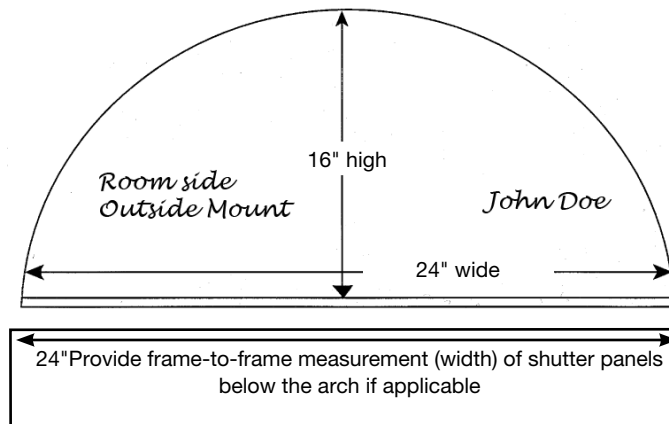

### Must note on template:

- Purchase Order Number
- Customer's Name
- Job Number
- Account Number

# Specialty Styles

## Sunburst Arch: Installation Method

Arches arrive with the louvers not installed and packed separately. Louvers are numbered on bottom edge from right to left on the bottom as you look at the interior (room) side.

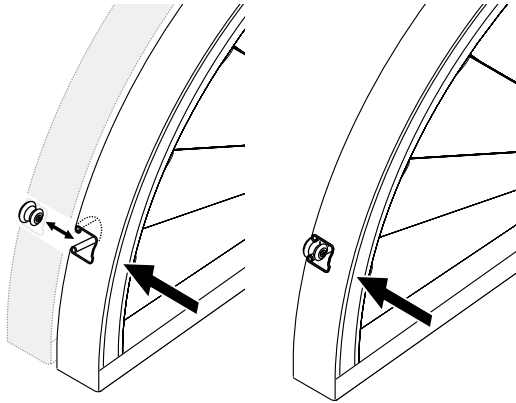

### Framed Arch — Installing Panel to Frame

Button catch (imbedded) is standard. Panels are attached to frame via button catch. The frame itself installs as a standard L, Z or Deco Frame.

## Frameless Arch Installation Option

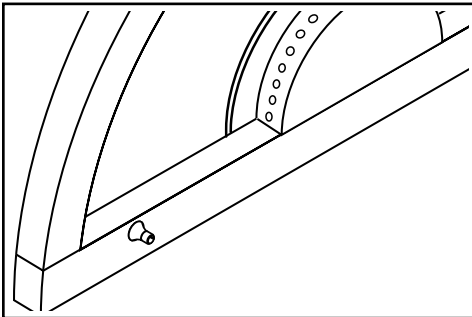

### Bulldog Catch

Bulldog catch works best with window openings that have a square edge. Allows arch panel to be removed for cleaning. Available in White.

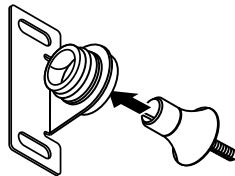

Suggested quantity usage:

Less than 36"—3

36" to 72"—5

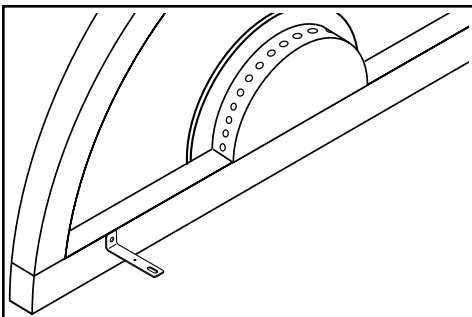

### L-Bracket

L-bracket works best with windows that have a bull-nosed edge. Long-throw on the L-bracket allows you to reach past the curved window edge to a flat surface. L-bracket is zinc colored only.

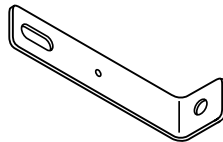

Suggested quantity usage:

Less than 36"—5

36" to 72"—7

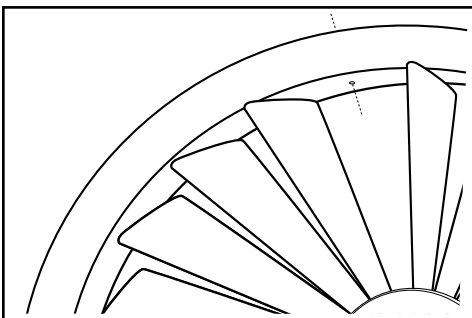

### Trim Head Screw

If using trim head screws to mount, pilot a hole diagonally from underside of curved frame and exit through rear of frame. Place screw hole near louver pin to help hide hole from view.

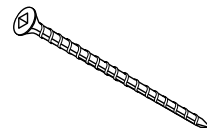



# Specialty Styles

## Arch and Angle Top Panel Shutters

- 2½", 3½" and 4½" louvers available
- Astragal, Hidden Tilt and Split Tilt available
- **NOTE:** Hidden Tilt only tilts up
- All frames except Tilt-Out Z-Frames available
- All panel configurations in standard shutters available
- Available frame configurations: 3-Sided (3S), 4-Sided (4S), 4-Sided with Sill Bottom (4SS)
- Split tilt and divider rails will have a +/- 2" tolerance
- Buildouts available for L-Frames and Deco frames and Arch without Sill Frame

### Louver Tilt is restricted up to 90° (degrees)

Louver tilt is restricted up to 90° (degrees) due to the curvature (or slope) at the top of the panel. A divider rail can be used to separate the upper arch portion from the lower rectangular portion. This will allow for full louver rotation of the louvers below the divider rail.

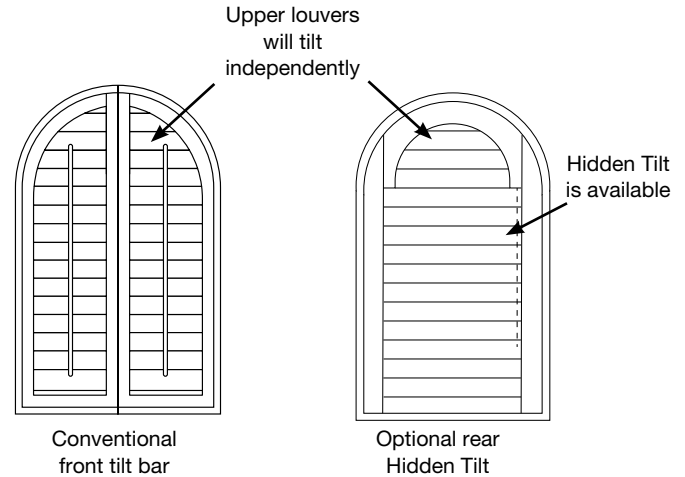

**NOTE:** Arch/angle top panels ordered with signature Z-Frame can not be under 30" in width.

## Measuring Leg Height and Divider Rail Height for Window Opening

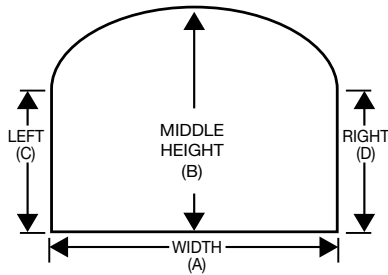

**Frames requiring WO measurement:**  
Z-Frame, Hang Strip and Direct Mount.

### Measuring leg height:

Measure from bottom of window up to arch "break point." Minimum leg height is 13".

### Measuring divider rail height:

Measure from bottom of window up to center of divider rail.

## Measuring Leg Height and Divider Rail Height for Frame-To-Frame Measurement

### Measuring Outside Mount L & Deco Frames

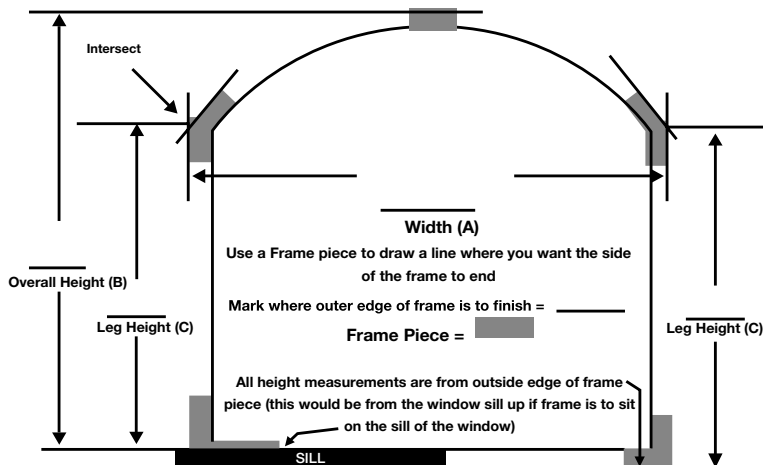

**Frames requiring F-F measurement:**

L-Frames and Deco frames

### Measure leg height:

Measure from bottom edge of frame up to arch "intersect" of the window (C). Minimum frame height is 13".

### Measuring divider rail height:

Measure from bottom of frame up to center of each divider rail.

**NOTE:** Divider rail requirements are the same as standard shutters. Only one divider rail available on arches/angles. Template required when the ordered height minus the leg height is over 54% of the width.

## Specialty Styles

### Arch and Angle Top Panel Shutters – Minimum/Maximum Height

See minimum and maximum charts.

Ordered Height Limitations for Arch and Angle Top Shutters				
	Frame Configuration	Frame Type	Minimum (inches)	Maximum (inches)
Window Opening	2-Sided	Hang strip/direct mount	15¼	96¼
	3-Sided	Z-Frames	16¼ <sub>16</sub>	97¼ <sub>16</sub>
	4-Sided with Sill Bottom	Z-Frames	16½	97½
	4-Sided	Z-Frames	16 <sup>15</sup> / <sub>16</sub>	97 <sup>15</sup> / <sub>16</sub>
Frame-to-Frame	3-Sided	L-Frame	16 <sup>15</sup> / <sub>16</sub>	97¼
	4-Sided with Sill Bottom	L-Frame	16%	97%
	4-Sided	L-Frame	17 <sup>7</sup> / <sub>16</sub>	98¼
	3-Sided	Deco Frame	17 <sup>7</sup> / <sub>16</sub>	98 <sup>3</sup> / <sub>16</sub>
	4-Sided with Sill Bottom	Deco Frame	17 <sup>15</sup> / <sub>16</sub>	98 <sup>15</sup> / <sub>16</sub>
	4-Sided	Deco Frame	19%	100%

**NOTE:** Minimum leg height is 13" on arch top panels and angle tops.

### French Door Shutters

- 2½" and 3½" louvers
  - Hide-a-Tilt™, Split Tilt and Double Mouse Hole available
  - Single panels hinged on the same side as the door
  - Standard L-Frame only
  - Order frame-to-frame
  - Outside mount only
  - Divider rails are not available
- Button catches plus magnets are standard to provide for a secure closure
  - Factory will automatically add build outs based on your louver size; see chart below
  - Split Tilt will have +/- 2" tolerance from requested location

Projection Based on Louver Size (inches)	Frame	Buildout (inches)
2½	2" L-Frame	0
3½	2" L-Frame	½

Manufacturing will automatically add Buildouts to your order according to the louver size. An additional ½" or 1" can also be requested if needed for louver clearance on larger trims. Factory will also make all adjustments to back plate elevation based on trim projection and extra Buildout requested.

**NOTE:** All French Door shutters for Cut-Out and no Cut-Out should be ordered at the same time.

### French Door Shutters: Minimum/Maximum French Door Sizes

	Minimum (inches)	Maximum (inches)
Width	14	29 <sup>13</sup> / <sub>16</sub>
Height	34 <sup>1</sup> / <sub>8</sub>	86¼

# Specialty Styles

## French Door Shutters: Cut-Out Options

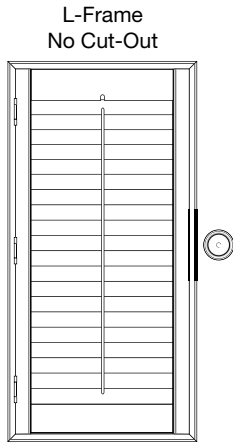

L-Frame  
No Cut-Out

This should only be ordered when installed next to a French door with cut-out, otherwise order it as a standard shutter.

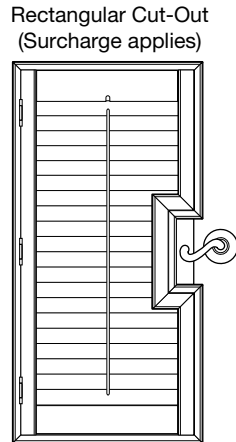

Rectangular Cut-Out  
(Surcharge applies)

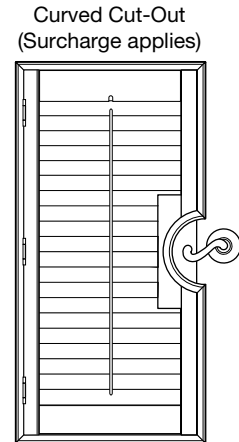

Curved Cut-Out  
(Surcharge applies)

### Order Rectangular Cut-Out When:

1. Choose if the base of the door hardware is rectangular.
2. Must specify width and height of the cut-out. There are no set standard sizes to conform to. There are no templates to use.
3. Be sure to make proper allowances for the door handle to pivot easily when determining your cut-out size.

### Order a Curved Cut-Out When:

1. Choose a cut-out if the base of the door handle (or knob) is round.
2. Five (5) standard cut-out sizes are available:  
Three (3) half-circles and two (2) half-ovals.
3. Other custom sizes of curved cut-outs are not available.
4. Be sure to make proper allowances for the door handle to pivot easily when determining your cut-out size.

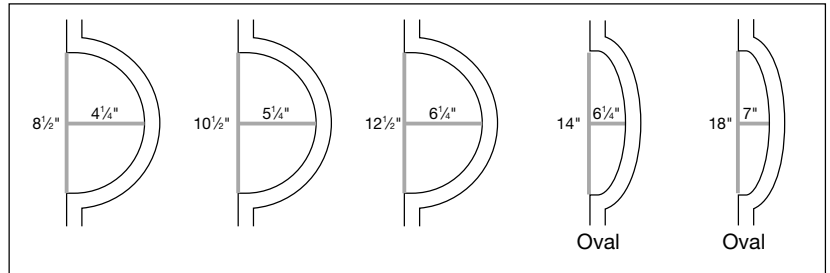

This image is taken from the backside of the French door order form.

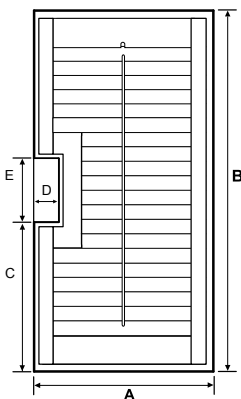

### Rectangular Cut-Out

- A=** Shutter Width  
- Frame-to-frame
- B=** Shutter Height  
- Frame-to-frame
- C=** Bottom of shutter frame  
to bottom of cut-out
- D=** Width of cut-out
- E=** Height of cut-out

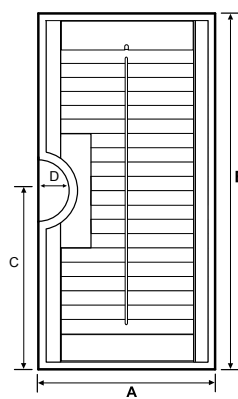

### Curved Cut-Out

- A=** Shutter Width  
- Frame-to-frame
- B=** Shutter Height  
- Frame-to-frame
- C=** Bottom of shutter frame  
to center of cut-out
- D=** Width of cut-out

## Specialty Styles

### French Door Shutters: Placement of L-Frame

L-Frame always sits outside of the trim, never on the trim. If no raised trim, place the L-Frame far enough beyond the glass to rest totally flat on the door and to avoid risk of breaking the glass when driving the mounting screws in place. Use caution when placing screws, as the glass often extends under the trim and could easily crack.

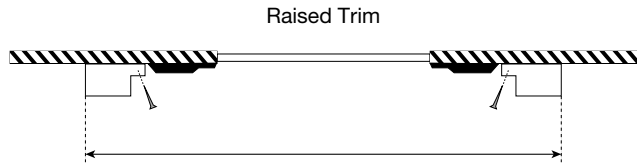

Always use **frame-to-frame measure format** for French doors

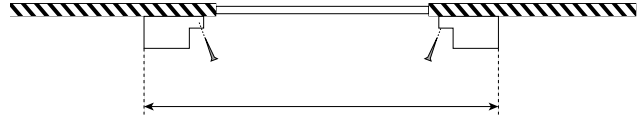

Always use **frame-to-frame measure format** for French doors

### French Door Shutters: Recessed Back Plate

A “recessed back plate” is required when there is insufficient space between the base of the door hardware and the glass trim to place L-Frame flat on the door surface.

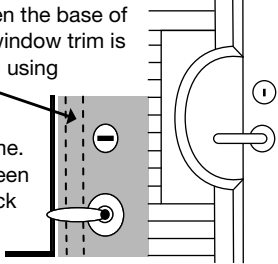
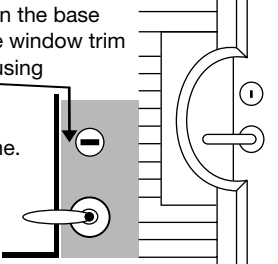
NO Recessed back plate is not needed	YES Recessed back plate is needed
<p>If measurement between the base of the hardware and the window trim is <b>greater</b> than 1½" when using a Standard L-Frame or 1" if using the Narrow Colonial L-Frame. (L-Frame does fit between hardware and trim), back plate does not need to be recessed.</p> 	<p>If measurement between the base of the hardware and the window trim is <b>less</b> than 1½" when using a Standard L-Frame or 1" if using the Narrow Colonial L-Frame. (L-Frame does not fit between hardware and trim), back plate does need to be recessed.</p> 
<p>If recessed back plate is required, the edge of back plate will align with inside edge of L-Frame. Installer does not specify amount of recess.</p>	

#### Caution:

1. When measuring (F-F) width and height, be sure that L-Frame can rest flat on the door surface and not be obstructed by the glass trim.
2. If “yes” is selected, the edge of the recessed back plate will be built to align with the inside edge of the L-Frame (as shown by the dotted line in the upper drawing).

## Specialty Styles

### Bypass Shutters

- Ideal solution for large windows and patio doors
- System consists of a double-top track and floor guides (no bottom track)
- Available in all louver sizes
- Available with Hide-a-Tilt™ and Split Tilt
- Available with Double Mouse Hole
- See the Minimum and maximum order sizes charts (Factory to determine panel size based on width ordered and configuration.)
- Panel made composite headers, box out and valance made of wood and painted to match
- Divider rail required over 72" ordered height
- Tracks wider than 144" will be spliced
- Header and valance could be spliced over 96"
- Mounting Options:
  - Outside mount — with or without box-out (box-out recommended)
  - Inside mount, minimum window depth 5 $\frac{3}{8}$ "
  - Exact frame-to-frame with box-out
- All Mounting Options:
  - Track and header Board: Unit includes 2 tracks installed to header. Header is 5 $\frac{1}{2}$ " deep and  $\frac{3}{4}$ " thick
  - Valances: 2 top treatment styles available 5" double beaded standard valance, 4 $\frac{1}{2}$ " decorative valance (optional)
  - Outside mount is available with stack back or custom header (see stack back and custom header section)

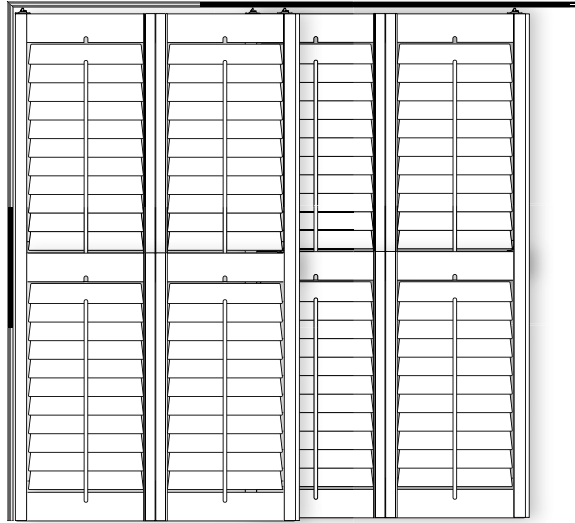

**NOTE:** Louvers must be closed in order for panels to pass each other.

### Valance Options



4 $\frac{1}{2}$ " Decorative Valance



5" Standard Valance

# Specialty Styles

## Bypass Shutters: Mounting Options



### Outside Mount— with Factory Additions:

**Width Measure (with box-out):** If no window trim: measure window opening size. If window trim: measure outside edge of trim to outside edge of trim and record as window opening size. **Regardless of ordered size, factory will add 3¼" to your overall ordered width.**

**NOTE:** When measuring, add more for bullnose drywall so that the frames mount completely on flat surface.

**Width Measure (without box-out):** If no window trim: measure window opening size. If window trim: measure outside edge of trim to outside edge of trim and record as window opening size. **Regardless of ordered size, factory will add 1¼" to your overall ordered width.**

**NOTE:** When measuring, add more to extend beyond window edge for more privacy.

**Height Measure (with or without box-out):** If no window trim: measure from floor surface to top of the window opening. If window trim: measure to top of window trim. **Regardless of ordered size, factory will add 2⅝" to your overall ordered height.**

**Other Measuring Considerations:** ½" Buildout is available.

**Valance Information:** Valance returns are included and wrap around the outside of the box-out if ordered. Returns are mitered and measure 5⅞" (Special valance width and return width available).

**Box-Out Information:** Optional side frames are 5½" deep and ¾" thick.

**Stack Back Information:** Optional to allow shutter panels to clear the window opening, factory will calculate based on ordered size. Custom/special header board size is also available if full stack back cannot be achieved.

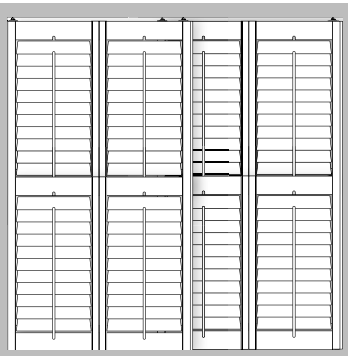

### Outside Mount— Exact Frame-to-Frame:

**Width and Height Measure:** Factory will not add or deduct from ordered size—measure width & height as finished frame to frame size including the box-out. Only available with box-out.

**Other Measuring Considerations:** ½" Buildout is available.

**Valance Information:** Valance returns are included and wrap around the outside of the box. Returns are mitered and measure 5⅞" (Special valance width and return width available).

**Box-Out Information:** Required box-out side frames are 5½" deep and ¾" thick.

**Stack Back Information:** Stack back and custom/special header board size is not available.

### Inside Mount— with Factory Deductions:

**Width Measure:** Order window opening width and factory will make a ½" deduction off the track for proper fit.

**Height Measure:** Order window opening height and factory will make a ½" deduction. The carriers are adjustable.

**Other Measuring Information:** Minimum window depth required for 5⅞". No buildouts available.

**Valance Information:** Special valance width available. Valance returns and special return width not available.

**Box-Out Information:** Not available.

**Stack Back Information:** Stack back and custom/special header board size is not available.

# Specialty Styles

## Bypass Track System Configuration Options – Only Configurations Available

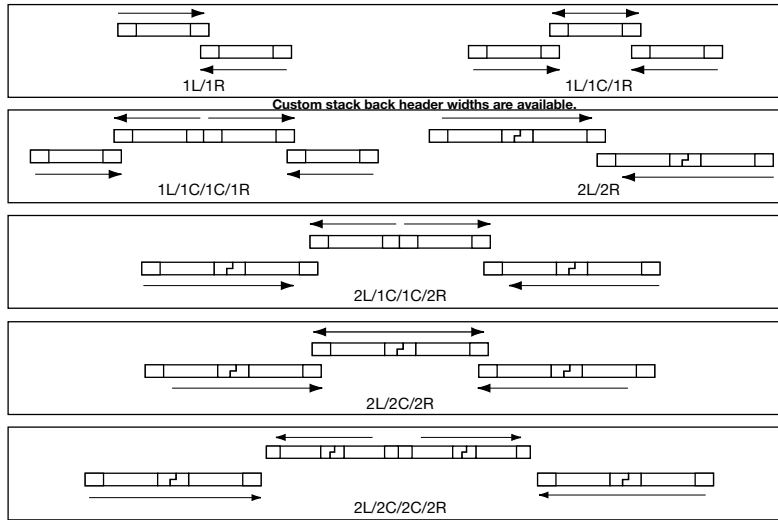

## Bypass Shutters: Minimum/Maximum Width Order Sizes By Panel Configuration

Panel Configuration	Example of shutter unit configurations using various panel combinations	Outside Mount with Additions		Inside Mount		Outside Mount-Exact	
		Order WO Size		Order WO Size		Exact Frame-to-Frame	
		Minimum Width (inches)	Maximum Width (inches)	Minimum Width (inches)	Maximum Width (inches)	Minimum Width (inches)	Maximum Width (inches)
1L / 1R		18	58	20	59	19¼	61¼
1L / 1C / 1R		27½	86	28½	88½	27¾	90¾
1L / 1C / 1C / 1R		37	117	38	118	36¼	120¼
2L / 2R		37¾	117¾	38¾	118¾	36	121
2L / 1C / 1C / 2R		56	176	58½	177	54¼	180¼
2L / 2C / 2R		57½	177½	58½	177¼	54¼	180¼
2L / 2C / 2C / 2R		76½	236½	77½	237½	71¼	239¼

Window opening is 33% with these panel configurations. stack back or custom header recommended.

Same minimum/maximum sizes apply if ordered with stack back options and with or without box-out.

**NOTE:** Combinations with a 2C, 2L or 2R will be rabbeted together and move as one unit.

Wood Bypass Height Minimum and Maximum		
Options	Minimum (inches)	Maximum (inches)
Outside Mount	15%	96%
Inside Mount	17¼	98¼
Exact	15%	98¼

### Setting Bracket Height (for outside mount without side frames)

For Wall Mount Bypass Shutter System  
Top of Angle Bracket to Floor:

Top of bracket will be 3⅞" above ordered height.  
This includes ½" clearance off the floor.

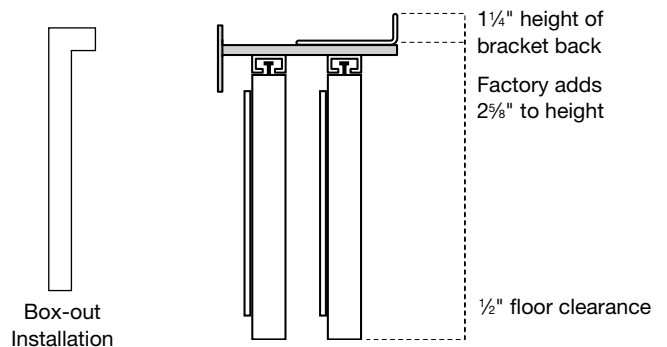

**NOTE:** With optional box-out, side frames determine the mounting height. Bottom edge of side frame is meant to touch the floor surface.

## Specialty Styles

### Bypass Track System

#### Stack Back Option

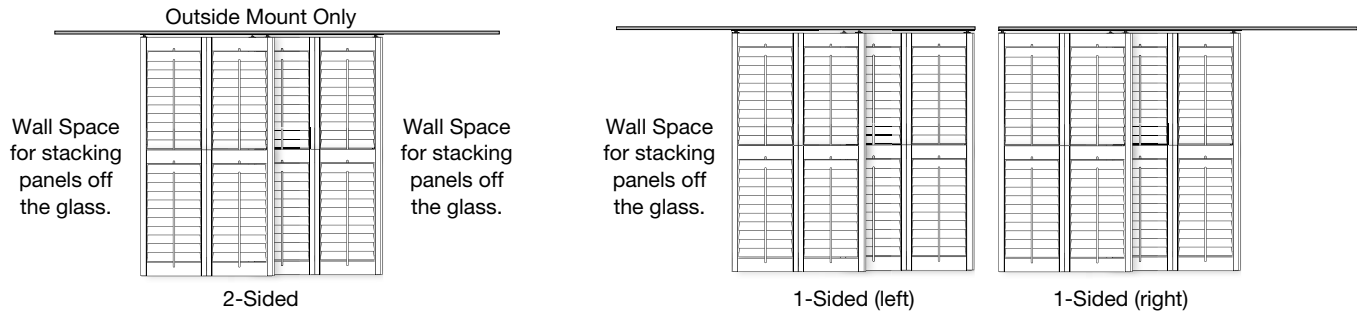

The stack back option allows for the shutter panels to clear the window opening, creating an unobstructed view. **Panels made to cover window. Header/track made larger so panels stack off glass.**

Measure only the window opening area for outside mount with stack back. Factory will calculate the correct stack back needed for full stack back. Custom header also available.

System consists of a double-top track and floor guides

**Calculating Approximate Stack Back:** Factory will add additional width to ordered size for stack back. Amounts vary, depending on the number of panels. See chart below for total (approximate) amount that will be added to the window opening size. This determines the approximate overall unit width.

% of Window Opening Size Added for Various Numbers of Panels				
2	3	4	6	8
50%	66%	50%	66%	50%

### Custom Header

If wall space is not available for complete stack back, custom header size may be ordered. Give window opening size and custom header size.

- Panels will be built to cover the window opening size
- The track, header, and valance will be built to the custom size requested
- Available on outside mount with additions only

**Ordering Entry Tip:** Enter the opening size as the ordered width.

Choose "no" for stack back and then place desired finished size in the custom header field.



# General Information

## Definitions

**Aligning Catch**—Concealed magnet and catch plate on back top side of the café panels. Used to provide a flush panel alignment.

**Astragal**—Covers clearance gap between two panels for the purpose of eliminating light gap. Integral to stile.

**Bifold**—Two panels are hinged together to lie flush against the window or wall.

**Bifold Track System**—Two or more hinged panels on a track. Panels do not lie flush against the window or wall.

**Box-out Frame**—Track system frame option that creates an outside mount application consisting of a three-sided frame with or without a decorative valance.

**Buildout**—Used in conjunction with L-Frames and Deco Frames to move panels away from window, allowing additional clearance for louvers to open.

**Bypass Track System**—Two or more panels on two overhead track that slide and pass each other.

**Café Style Shutters**—Cover the lower portion of an opening. They can be made to any height within product specifications.

**Direct Mount**—Mounting the shutter panels directly to the window casing.

**Divider Rail**—A rail that divides the shutter panel into two horizontal sections. It is used to add strength to a tall panel or add a decorative touch.

**Double Mouse Hole**—Recess on the top and bottom rail allowing for the louvers to be completely closed in either direction. Close in upward position for optimal closure.

**Guide**—Component part used with bypass configurations to lead the panels so that they do not project into the room.

**Hang Strip**—The mounting frame that is used for inside mount shutter panels.

**Inside Mount**—A shutter that is mounted on the inside of an opening.

**Light Block**—Square rail that blocks light between the window sill and the shutter panel, used with direct mount, hang strip, 2-sided frames and 3-sided frames.

**Louvers**—The movable fins inside the shutter panel.

**Mouse Hole**—Recess in the top rail of the panel that the lift rod rests in when the louvers are completely closed. Standard is single mouse hole.

**Outside Mount**—A shutter that is mounted on the outside of an opening.

**Panel**—The part of the shutter that consists of a set of louvers, two rails and two stiles.

**Rabbet Stile**—A special cut on the stiles that allows the panels to overlap. Helps control light penetration between the panels.

**Rails**—The top and bottom solid portions of a panel that frame the louvers.

**Square Window**—Diagonal measurements must be within ¼" difference. Windows that are not square will need to have the shutter mounted to the outside of the window opening.

**Stack Back**—Configuration that allows the panels of the bypass or bifold track system to completely slide beyond the window opening.

**Stile**—The vertical portion of the panel frame to which the louvers are anchored.

**Strike Off**—Sample color swatch to be approved prior to the production of the order.

**Tilt Bar**—A vertically mounted bar located on the front of the shutter.

**T-Post**—A vertical post that divides the shutter into multiple sections (used with wider shutters).

**Window Depth**—The distance from the surface of the wall to the closest part of the window (examples: latch, crank, frame, etc.).

# General Information

## Warranty

### LIMITED LIFETIME WARRANTY

Springs Window Fashions warrants your Shutters will be free from original defects in materials or workmanship for as long as the original purchaser owns the product. Under the Limited Lifetime Warranty, the obligations of Springs Window Fashions are limited to the repair or replacement of parts or product found to be defective. Springs Window Fashions is not responsible for shipping costs or labor costs for measuring and taking the product down or reinstalling the product. If repairs are made under this warranty, the repairs will be made with like or similar parts.

This warranty does not cover conditions or damages caused by accidents, alterations, misuse, exterior use, or failure to follow instructions for measurement, installation, cleaning or maintenance. In addition, normal wear and tear are not covered by the Limited Lifetime Warranty.

Some wood materials may warp in high humidity areas. Springs Window Fashions considers these occurrences normal wear and tear and they are not covered by this warranty.

### LIMITATION OF DAMAGES/DISCLAIMER OF WARRANTIES

THIS LIMITED WARRANTY DOES NOT COVER, AND IS INTENDED TO EXCLUDE, ANY AND ALL LIABILITY OF SPRINGS WINDOW FASHIONS, WHETHER UNDER THIS LIMITED WARRANTY OR UNDER ANY WARRANTY IMPLIED BY LAW, FOR ANY INDIRECT OR CONSEQUENTIAL DAMAGES. EXCEPT AS EXPRESSLY PROVIDED IN THIS LIMITED WARRANTY, SPRINGS WINDOW FASHIONS HEREBY DISCLAIMS ALL WARRANTIES TO THE EXTENT PERMITTED BY LAW. ANY IMPLIED WARRANTIES THAT CANNOT BE DISCLAIMED ARE, TO THE EXTENT PERMITTED BY LAW, LIMITED IN DURATION TO FIVE (5) YEARS.

Some states do not allow the exclusion or limitation of incidental or consequential damages, so the foregoing limitation or exclusion may not apply to you. This Limited Warranty gives specific legal rights, and you may also have other rights that vary from state to state. No person is authorized to extend or alter this Limited Warranty.

### WARRANTY SERVICE

Warranty claims must be accompanied by the original sales receipt as well as details regarding the nature of the problem, location of the product, etc. If your product is returned, please retain a copy of the shipping information for your records.

To obtain warranty service contact:

Customer Service Center  
Springs Window Fashions, LLC  
8467 Route 405 Highway South  
PO Box 500  
Montgomery, PA 17752-0500

You may also email [windowfashions@springswindowfashions.com](mailto:windowfashions@springswindowfashions.com) or call 1-877-675-0089

## Care Instructions

Occasional light vacuuming with a brush attachment should keep shutters clean. More severe soiling can be removed by using a soft cloth and a mild detergent and water solution.

# Pricing

## Composite Shutters Pricing

### Composite Pricing

#### Frame Type

	<b>Reynosa Manufacturing</b> <small>(from 10 working days to ship)</small>	<b>Asian Manufacturing</b> <small>(from 7 weeks to deliver)</small>
Hang Strip, Direct Mount . . . . .	\$47.30 per square foot . . . . .	\$42.30 per square foot
L-Frames (Frame-to-Frame) . . . . .	\$48.30 per square foot . . . . .	\$43.30 per square foot
Z-Frames, Tilt-Out Z-Frame (Window Opening) . . . . .	\$48.30 per square foot . . . . .	\$43.30 per square foot
Deco Frames (Frame-to-Frame) . . . . .	\$48.30 per square foot . . . . .	\$43.30 per square foot
Bifold/Bypass Track Systems . . . . .	\$50.00 per square foot . . . . .	NA

#### Additional Surcharges

Arch & Angle Panel Shutters . . . . .	\$110.00 per square foot
Bifold/Bypass Box-out* . . . . .	15%
Bifold/Bypass Stack Back* . . . . .	5%
Cafe Shutter with 4-Sided Frame. . . . .	5%
French Door Cut-Out** . . . . .	\$450.00
Hide-a-Tilt™ Bar . . . . .	10%
Sunburst Arches (Frameless) . . . . .	\$123.00 per square foot
Sunburst Arches (Framed) . . . . .	\$137.00 per square foot
Stainless Steel Hinge . . . . .	5%
Wood Sill Cap. . . . .	10%

\*Calculate overall square feet of bypass. Use overall square foot price to calculate surcharge for box-out and stack back.

\*\*Calculate the overall square footage of the French Door panel using the L-Frame price; then add the surcharge

**NOTE:** Composite shutter sunburst arches, composite arches and angled panel shutters, and french door cut-outs are manufactured in Asia with an 8 week lead time.

### Composite Characteristics

- Made with PVC base with calcium carbonate and other fillers
- Perfect for high-humidity areas
- Color will not fade
- Easy cleaning with mild detergent and water

Panel Size Limitations	Minimum (inches)		Maximum (inches)	
	2½ and 3½	4½	2½ and 3½	4½
Single Panel Width (Reg.)	9	9	30	26
Single Panel Width (Bifold)	9	9	24	24
Panel Height	15	15	96	96



Graber is a brand of Springs Window Fashions, the Best Experience Company 

Graber and the Graber logo are registered trademarks of Springs Window Fashions, LLC.

19-0262-04 (07/16) 16-2991|S16-2828